



Ophthalmic Operating Theatre Practice: A manual for lower-resource settings

Editor: Heather Machin

SECOND EDITION

“ Alone we can do so little:
Together we can do so much ”
- Helen Keller

This book is dedicated to:
First edition authors – Ingrid Mason (Cox) and Sue Stevens

Ophthalmic Operating Theatre Practice – A manual for lower-resource settings
© Second Edition 2016

Editor Heather Machin

Published by the International Centre for Eye Health, London School of Hygiene and
Tropical Medicine <http://iceh.lshtm.ac.uk>

ISBN # 978-0-9955190-0-8

Contact: Admin@cehjournal.org

The editor and authors share copyright for this work with the publisher.

The work is licensed under a Creative Commons Attribution-NonCommercial 4.0
International License <https://creativecommons.org/licenses/by-nc/4.0/>

Unrestricted use, distribution, and reproduction of any part of this manual is
permitted in any medium for non-commercial purposes, provided that the licensors
are acknowledged, any changes are indicated and a link to the license is provided.



Contents

Section 1: General – Something everyone should know	10
Contributors: David Lewis, Heather Machin and Babar Qureshi	
Professionalism.....	11
Caring for Ourselves.....	12
Global Initiates	12
Section 2: Ocular Conditions Requiring Surgical Treatment	17
Contributors: Hunter Cherwek, John Cooper, Kristen A Eckert, Heather Machin, Ingrid Mason, Neil Murray, Heiko Philippin, S. Grace Prakalapakorn, Van C. Lansingh and the Aravind Hospital Team: Indira Durai, Namratha Gaikwad, Deeba Ishrath, Dr.Jyothirathod, Usha Kim, A.Karthik Kumar, Vrushali Patil, R.Sharmila, and Sr.Sundari	
Anatomy Diagrams.....	18
Cataract.....	20
Glaucoma (Trabeculectomy).....	21
Diabetic Eye Disease.....	25
Vitreoretinal Surgery (Vitrectomy).....	26
Oculoplastics.....	27
Paediatric Ophthalmology.....	28
Corneal Surgeries.....	35
Pterygium.....	38
Combined Surgeries.....	40
Trachoma (Trichiasis).....	40
Section 3: Emergency Triage for Surgery and Ocular Hospital Acquired Infections and Inflammatory Conditions	44
Contributors: Hunter Cherwek and Janet Marsden	
Emergency Triage for Surgery.....	45
Ocular Hospital Acquired Infections and Inflammatory Conditions (Endophthalmitis and TASS).....	48
Section 4: Care of the Surgical Patient	51
4a-Communication, Pre-Arrival and Pre-Operative (and Biometry)	51
Contributors: Heather Machin, Mariano Yee Melgar, Fiona O’Sullivan, and Marilyn Watkins-Ramdin	
Building Relationships, Communication and Trust.....	52
Biometry – for cataract surgery patients only.....	52
Pre-Operative Care.....	53
Informed Consent and Day of Surgery.....	53
Transferring and Positioning a Patient.....	56
4b - Anaesthetics, Recovery and Discharge	58
Contributors: Sandra P Burnett and Heather Machin	
Anaesthetics.....	59
Patient Fasting.....	61
Pre-Operative Anaesthetic Care.....	62
During and After the Surgery.....	63
Local Anaesthetic.....	63
Sedation.....	66
General Anaesthetic.....	66
Caring for special categories of patients.....	69
Anaesthetic Emergencies.....	71
Recovery (Post-Operative Care).....	71
Discharge.....	74

Contents

Section 5: Operating Theatre Processes	77
Contributors: Elise Chick, Heather Machin, and Sofia Solazar Tamay	
Theatre Design.....	78
Dress Code, Personal Protective Equipment (PPE) and Personal Hygiene.....	81
Cleaning the OT.....	82
Commissioning an OT.....	83
Surgical Hand Washing.....	84
Gowning.....	86
Gloving.....	88
Drapes, Patient Preparation and the Sterile Field.....	89
Preparing the patient.....	91
Documentation.....	92
Techniques for Passing Items to the Surgeon.....	92
Care of Specimens and Tissue for Transplantation.....	93
Surgical Count.....	97
Preparing and Using Cytotoxics.....	97
Managing Additional People in the OT.....	97
End of the Case.....	97
End of the List/Day.....	98
Section 6: Equipment, Consumables and Protheses Care	99
Contributors: Ismael Cordero, Lynette Grubwinkler, and Heather Machin	
Equipment Maintenance Programmes and Specialists.....	100
Storage and Cleaning (of optical items).....	100
Optical Items.....	101
Electrosurgical Units.....	105
Cryotherapy Machine.....	106
Lasers in Surgical Ophthalmology.....	107
Consumables and Protheses.....	108
Section 7: Instruments and Equipment Sterilization Services	112
Contributor: Heather Machin	
Principles of Care.....	113
Department Design.....	113
Sterilizers.....	114
Water.....	116
Cleaning Solutions.....	117
Setting-Up Each Day.....	118
Surgical Instrument Familiarity.....	118
Decontamination.....	120
Wrapping and Labelling.....	120
Sterilization Procedure.....	122
Care and Management Once Sterilized.....	123
Tracking and Log Book Systems.....	124
Sterilization Methods.....	124
Other Methods.....	126
Section 8: Ophthalmic Surgical Instruments	130
Contributor: Heather Machin	
Introduction.....	131
Instrument Types.....	131
Examining the Integrity – and Packaging for Reuse.....	136
Standard Instrument Sets.....	136

Contents

Section 9: Management	138
Contributors: Elise Chick, Emma Griggs, Phillip Hoare, Heather Machin, Noela Prasad and Lo Vola	
Management.....	139
Human Resources (HR).....	140
Policies and Documents.....	141
Clinical Quality Management (QM).....	141
Incident Reporting.....	142
Material Safety Data (MSD).....	142
Occupational Health and Safety (OHS).....	142
Education.....	145
Supply Chain Management (SCM).....	147
Health Information and Data.....	149
Section 10: Outreach and Working with Teams, Volunteers and Non-Government Organisations	153
Contributors: Heather Machin and R. Meenakshi Sundaram	
Outreach.....	154
7 Strategies for Effective Outreach Programmes.....	154
Packaging and Transfer of Stock.....	158
Working with Teams, Volunteers and Non-Government Organisations (NGO).....	158
APPENDIX	161
Appendix A: Abbreviations, Common Sounding Names, Glossary and Units	161
Abbreviations – containing letters and numbers.....	162
Abbreviations – letters only.....	162
Common Interchangeable English Sounding Names/Words.....	162
Glossary.....	163
Units.....	166
Appendix B: Templates Package	167
Instrument Tick List.....	168
Hand Hygiene Tools.....	169
Competency	173
Stock Card.....	174
Policy and Work Instructions.....	175
Standing Orders.....	177
Preference Cards.....	181
Outreach Documentation.....	183
Patient Chart Documents (Adult Care).....	188
Safe Site Surgery Checklist.....	189
Pre-Arrival Care Planning.....	190
Pre-Surgery Screening.....	191
Pre-Anaesthetic Nursing Assessment.....	193
Peri-Operative Nursing Notes.....	194
Doctor’s Post-Anaesthetic Orders.....	196
Discharge Instructions.....	198
Appendix C: Peer and Professional Associations Listing	199
Nursing.....	200
Combined Professional Regional Associations.....	200
Other.....	200



Heather Machin

The Editor

Heather Machin is an ophthalmic Operating Theatre Registered Nurse; consultant to the Fred Hollows Foundation NZ; Vice-President to the Australian Ophthalmic Nurses Association Victoria; Project Officer to the Lions Eye Donation Service, Centre for Eye Research Australia, Royal Victorian Eye and Ear Hospital, Ophthalmology, University of Melbourne, Department of Surgery; Project Officer to the Eye Bank Association of Australia and New Zealand; Developer for the Global Alliance of Eye Bank Associations; contributor to the Community Eye Health Journal; and prior editorial board member of the International Journal of Ophthalmic Practice.

Having also worked for other ophthalmic NGOs including ORBIS International and ONA Network, Heather has worked on projects in over 30 countries and published multiple papers, editorials and text chapters on global ophthalmic nursing practice and led the development of a bioethical framework for ocular tissue in Australia and New Zealand. She has also received awards and nominations from; Rotary Australia, Pride of Australia Medals and the University of Queensland's Young Alumni of the Year, and has developed multiple post-graduate training programs including those for the University of Melbourne, Queensland University of Technology, and the Fiji National University (delivered in conjunction with the Pacific Eye Institute, Fiji and Devine World University, Papua New Guinea). Heather has a post-graduate qualification in professional communications and public relations, freelance journalism, ophthalmic nursing and a Masters of Business Administration. Heather currently resides in Australia and routinely visits and participates in programs around the world.

Contributing Authors

1. Sandra P Burnett, RN BA. University of Florida Health, Volunteer ORBIS International, Nurse Advisor Fred Hollows Foundation NZ and member of the American Society of Ophthalmic Registered Nurses – USA
2. Dr Hunter Cherwek. Global Ophthalmologist - USA
3. Elise Chick, RN. Eyes for Africa – Ethiopia, Fred Hollows Foundation NZ, Ophthalmic Theatre Nurse Manager - Royal Victorian Eye and Ear Hospital - AU
4. John Cooper RGN BSc(Hons), MRes, MSc, Advanced Nurse Practitioner and Oculoplastic Specialist Nurse. Manchester Royal Eye Hospital - UK
5. Ismael Cordero, Biomedical Service Manager. Gradian Health Systems and American College of Clinical Engineering (ACCE) member - USA
6. Dr Indira Durai, Senior Consultant. Aravind Eye Hospital - India
7. Kristen A. Eckert, MPhil, Independent Consultant. Tapachula, Chiapas - Mexico
8. Dr Namratha Gaikwad, Senior Medical Consultant – Orbit. Aravind Eye Hospital, Madurai - India
9. Emma Maxey Gregg RGN, Theatre Manager. Moorfields Eye Hospital, Bedford Satellite Site - UK
10. Lynette Grubwinkler, RN, Ophthalmic Theatre Nurse. YWAM Medical Ships - Australia Ltd, Queensland Eye Hospital - AU
11. Phillip Hoare, IAPB Procurement Specialist – UK
12. Dr Deeba Ishrath, Senior Consultant. Aravind Eye Hospital - India
13. Dr Jyothirathod, Medical Consultant – Orbit. Aravind Eye Hospital, Madurai - India
14. Dr Usha Kim, Chief – Orbit and Oculoplasty. Aravind Eye Hospital, Madurai - India
15. Dr A Karthik kumar MS, Consultant, Retina Services. Aravind Eye hospital, Madurai -India
16. David Lewis OAM, Director Strategic Programs. CBM Australia - AU
17. Janet Marsden, PhD MSc BSc RGN OND FRCN FFEN, Professor of Ophthalmology and Emergency Care. Manchester Metropolitan University - UK
18. Ingrid Mason, RGN, MSc and Masters International Community Development. FAIRMED - Switzerland
19. Dr Mariano Yee Melgar, Ophthalmologist. Visualiza - Guatemala
20. Dr Neil Murray, FRANZCO. The Fred Hollows Foundation NZ - NZ
21. Fiona O'Sullivan, RN, Grad.Cert in Clinical Teaching. Queensland Eye Hospital, and Executive Member of Australian Ophthalmic Nurses Association Queensland - AU
22. Dr Vrushali Patil, Paediatric Ophthalmology and Strabismus department. Aravind Eye Hospitals - India
23. Dr S Grace Prakalapakorn, MD, MPH, Assistant Professor of Ophthalmology and Paediatrics. Duke University - USA
24. Dr Noela M Prasad, Medical Officer. The Fred Hollows Foundation - AU
25. Dr Heiko Philippin, MD. International Centre for Eye Health, London School of Hygiene & Tropical Medicine, and Department of Ophthalmology, Kilimanjaro Christian Medical Centre, Moshi - Tanzania
26. Dr Van C. Lansingh, MD, PhD. Help Me See, Latin America Medical Officer; Director of Education at the Instituto Mexicano de Oftalmología, Santiago de Queretaro, Queretaro – Mexico
27. Sofia Salazar Tamay, RN, Director of Nursing. Department of Ophthalmology, Instituto Regional de Oftalmología, Trujillo - Peru
28. Professor Dr R Sharmila, Senior Consultant, Glaucoma Services. Aravind Eye Hospital, Madurai - India
29. R Meenakshi Sundaram. Community Outreach, Aravind Eye Hospital, Madurai - India
30. Sr Sundari, OT Department – Orbit. Aravind Eye Hospital, Madurai - India
31. Losana V.Vola, Dip.Nsg, PGCDEC, PGDEC, MCEC, Clinical Sister. Lautoka Hospital, Ministry of Health – Fiji
32. Dr M Babar Qureshi MD, BM Bch, DOMS, MSc, DHPE, FAMS, Global Advisor Eye Health. CBM - UK
33. Marilyn Watkins-Ramdin, COMT ROUB. President of the Caribbean Association of Ophthalmic Technical Personnel. Member of the Association of Technical Personnel in Ophthalmology (ATPO) - Barbados West Indies

Special thanks to our peer reviewers and assistants whose involvement and support behind the scenes has also been invaluable

1. Isa Iya Abdulkadir, Cert.Prog.Mgt (LAICO), Cert.V2020 (LSHTM), HNC Computer Science - ABU, ADPA, OND, RN. Independent Consultant - Public Eye Health Programme Management - Nigeria
2. Ms Sigappi.PR, MLOP Training Division Manager. Aravind Eye Hospital, Madurai - India
3. Barbara Astle, PhD, RN, Associate Professor. Director for the Centre of Equity & Global Engagement (CEGE), School of Nursing, Trinity Western University - Canada
4. Pawan Baral, B.Sc Optometry, Education Manager-PNG. Fred Hollows Foundation NZ - Papua New Guinea
5. Lisa Buckland, Manager, PostGradCert Sci (quality assurance). Lions Eye Bank of Western Australia - AU
6. Christine Burgess, Sterilization Department Technician - AU
7. Catherine Cross, Independent Consultant. Formerly Sightsavers - UK
8. Karl C. Golinik, MD, Med, Professor and Chairman. Department of Ophthalmology, University of Cincinnati & the Cincinnati Eye Institute - USA
9. Dr Una Kyriacos, PhD, Fellow of the Academy of Nursing of South Africa, PG Diploma in Oph.Nursing, RN, RM, Division of Nursing and Midwifery. University of Cape Town - South Africa
10. Maggie McNeil. Graphic Designer - AU
11. Nguyen Thi Ngoc Minh, RN, BN, MNsc, Nursing lecturer. Danang University of Medical Technology and Pharmacy - Vietnam
12. XiaoYing Liu, Registered Nurse - China
13. Ahmad Ma'ali, RN, BSN, MSc, ENB 346, PGCE, NP, Nursing Director. St. John Eye Hospital - Jerusalem
14. Janet Marsden, PhD MSc BSc RGN OND FRCN FFEN, Professor of Ophthalmology and Emergency Care. Manchester Metropolitan University - UK
15. Jill Keeffe, PhD. Professor. L V Prasad Eye Institute, Hyderabad India, and the University of Melbourne Department of Surgery - Ophthalmology - India and AU
16. Ma. Dominga B. Padilla, MD, Associate Professor. University of the Philippines College of Medicine Diplomate in Ophthalmology - The Philippine Board of Ophthalmology, Fellow -the Philippine Academy of Ophthalmology, and Founding President of the Eye Bank Foundation of the Philippines and Council Member - Asia Cornea Society - The Philippines
17. Dr Graeme Pollock MPH PhD, Director, Lions Eye Donation Service, Centre for Eye Research Australia, Royal Victorian Eye and Ear Hospital, Ophthalmology, University of Melbourne, Department of Surgery - AU
18. Susanne Raynel, MA (Nursing), OND, RGON. Department of Ophthalmology, Faculty of Medical and Health Sciences, University of Auckland, Ophthalmology Department, Auckland District Health Board - NZ
19. Adele Stoneley, Educator. BA, CertEdSt, DipProfStEd, CertAdvProfSt - AU
20. Dr Gerard Sutton, MBBS MD FRANZCO, Professor. Sydney Medical School, Sydney University & Lions NSW Eye Bank, Sydney Eye Hospital - AU
21. Konio Szetu, RN, PGDEC, JACHAPO - COA and OSA, Senior OT Nurse and Clinical Nurse Advisor. Fred Hollows Foundation NZ - Solomon Islands
22. Dr Margaret Watson, Anaesthetist, FANZCA FRCA, Eyes for Africa - AU
23. Elmien Wolvaardt Ellison, Editor. Community Eye Health Journal - UK

Permissions:

Resources/Images

1. Aravind Eye Hospital - India
2. Aurolab - India
3. Duke University Hospital - USA
4. Eye Bank Association of Australia and New Zealand - ANZ
5. Eye-Sight for Sight Restoration - USA
6. Fred Hollows Foundation NZ - NZ
7. Hand Hygiene Australia - AU
8. Ismael Cordero - USA
9. Lions Eye Donation Service, Centre for Eye Research Australia - AU
10. Janet Marsden - UK
11. Ocuscan Australia - AU
12. ORBIS International (Richard Jorgenson) - USA
13. Pacific Eye Institute - Fiji
14. Queensland Eye Hospital - AU
15. YWAM Medical Ships - AU

Photo thanks

Dr Gabriella Ruiz Gonzalez - Mexico, Dr Delfitri Lutfi - Indonesia, Jennifer Mor - Papua New Guinea, Graeme Nichols - NZ, Tima Nukusere Seru - Fiji, Viniana Tagi - Fiji, and Dr Hayley Waugh - AU

Forwards

Professor Allen Foster, OBE, FRCS, FRCOphth

For all those interested in improving the delivery of surgical eye care services in low income countries, it will be excellent news to see the second edition of the Ophthalmic Operating Theatre Practice – A manual for lower-resource settings now available.

The Editor Heather Machin builds upon the first edition of the manual and the Ophthalmic Nursing Series in the Community Eye Health Journal. She incorporates the expertise of more than 33 other authors and her own widespread international experience to produce an up to date, comprehensive, professional and very practical manual for all eye care professionals. The manual covers the preparation of patients undergoing eye surgery, the nursing aspects of major eye operations, and the reception and post-operative care of patients undergoing eye surgery.

Emphasis is given to the provision of cataract surgery but other conditions covered are glaucoma, diabetic retinopathy, trichiasis, pterygium as well as sections on corneal, oculo-plastics, vitreo-retinal surgery and eye surgery in children.

There are excellent practical chapters describing the care and use of eye surgical equipment and instruments as well as the appropriate sterilisation techniques and an emphasis on safety.

This is an essential practical manual for Eye Health Professionals working in Operating Theatres in low and middle income countries.

Professor Allen Foster, OBE, FRCS, FRCOphth.

Chair of the Editorial Committee, Community Eye Health Journal

Professor of International Eye Health, London School of Hygiene and Tropical Medicine - UK

Professor Janet Marsden, PhD RN OND

The phrase, 'knowledge is power' was coined by Francis Bacon, scientist and philosopher, in 1597. It has been used many times since, and it remains true to this today.

In the context of eye care, this manual provides the knowledge that leads to good care. It arms the ophthalmic team with important information and skills required to enhance their ability to care for patients with eye problems in a surgical environment.

The special challenges of working on an organ so small and so complex is also important to understand, and successful surgery can recover both lost sight, and prevent sight loss in others. Therefore, it is important that everyone on the team is working towards the success of that surgery.

Surgical success is not just about the procedure and those undertaking it. It is about the whole process - from the presentation of the patient, to the prioritisation of their problem and diagnosis. It is also about the environment in which surgery is undertaken - along with safety and cleanliness; the instruments used and the care of the patient and those providing the care. Just as important is knowledge of infection prevention and control, equipment management, instrumentation and the management of the supply chain and the people involved in the service.

By working through this manual, members of the ophthalmic team will be provided with a working knowledge of ophthalmology and the importance of providing individualised and effective care to their patients.

Professor Janet Marsden, PhD RN OND.

Editorial Committee, Community Eye Health Journal

**Professor of Ophthalmology and Emergency Care.
Manchester Metropolitan University – UK**

Introduction

14 years have passed since Ingrid Mason (Cox) and Sue Stevens - the original authors, published edition one of this text - with the emphasis being on supporting services primarily in Africa. Little did they know at that time, the text would become a staple training tool for many nurses and technicians around the world, who would come to rely on its teaching as the basis of their daily practice.

Fast forward to 2014 where I found myself working with the Pacific Eye Institute- Fiji for the Fred Hollows Foundation NZ, where I discovered that the text is no longer being published and that there were no alternative texts available - despite global calls for nursing resources. And so, I began the journey to find out what we could do about it as a global community.

Armed with a team of experts from a variety of settings and countries, we worked together to develop an edition that reflects today's modern collaborative approach to practice. Emphasising responsible practice, unity and equitable input, the aim was to ensure that this text truly reflects team integration, empowerment and progression, and the degree of success needed in health systems of today. We also made the decision to engage an extensive range of professionals to ensure the text could be used in a wide range of settings throughout the world.

The text also leads directly into the International Council of Nurses and the WHO Global Strategy on Human Resources for Health: Workforce 2030, to primarily strengthen human resources for health (HRH) capabilities - which remain a fundamental aspect of the Sustainable Development Goals and those of the International Agency for the Prevention of Blindness.

With greater emphasis on systems the text tackles service delivery at the root. This is because systems are intrinsically embedded into; work cultures, daily practice, policy, governance, management structures and support mechanisms - of which nurses and technicians play a vital role, and are necessary for providing consistent and equal levels of service to patients. If developed effectively, systems can support and empower professionals at all levels and ensure services are followed through for the betterment of the patient and those working in the system.

Those involved in this edition have worked to integrate these key elements alongside original aspects from edition one, to provide teaching on; daily management, management of self, understanding common eye conditions requiring surgical intervention, how to work within the operating theatre facility, and how to safely care for the patient.

While the text is focused on the Operating Theatre - or Operating Room as it is also referred to, elements can be applied to minor procedure and outpatient clinics, mobile health units, wards and community health situations. This is because a majority of what this text discusses is universally applicable - and generally does not cost a great deal. For example hand washing, completing documentation and working safely, can take place regardless of the sector, work environment and level of resource.

The text can also be utilised by existing professionals requiring a refresher, and those new to the profession. It also provides an introduction to non-medically-trained development professionals and support staff who may find themselves involved in ophthalmic or operating theatre programs or organisations. This text will provide them with an understanding of how ophthalmic health care facilities function and the important relationship, role and leadership of the ophthalmic nurses and technicians within it - including their compliance requirements and the sector's expectations of such licensed professionals.

I would like to take this opportunity to thank the original authors, the current contributors who adapted and up-dated the original text, all the peer reviewers and supporters, and the team at the Community Eye Health Journal, who volunteered their time and expertise towards edition two. It has been a true global collaborative effort and one that I have personally enjoyed being a part of. I have learnt a great deal from their participation, knowledge and dedication and could not have achieved it without them.

Finally, if you or your organisation has found this text useful, then we would love to hear from you. Knowing if it has changed the outcomes of just one patient or taught one new technique or improved the services in one facility or team, means a great deal to those involved. It symbolises the collective involvement and movement of our sector to improve outcomes for our patients no matter where they are in our world - and we need to share our stories and experiences.

Happy learning and keep safe

Heather Machin, RN, MBA

Editor

hmachin@hollows.org.nz or Admin@cejournal.org

SECTION 1

Something everyone should know.

Contributors: David Lewis, Heather Machin and Babar Qureshi



No matter where a nurse or technician works, or what type of facility they are working in - be it a public, private or university hospital, day surgery, mobile clinic, or community health department, or if they live in a high or low resource location, or in the city or the country - there are some things which all nurses and technicians need to know and be mindful of.

This section will outline important points regarding professionalism, and taking care of ourselves. It will conclude with an exploration of the current global initiatives for implementation into routine practice.

Professionalism

Professionalism includes more than just having a title or a position in the organisation. It is about the essential drive and care that professionals have for patients and other members of their team. Professionalism is an outward demonstration of why we became an ophthalmic nurse or ophthalmic technician. Professionalism can be demonstrated through a variety of ways.

Punctuality

Always come to work on time. A lot of healthcare is related to time-management, for example, when working in a ward, medication needs to be administered at a certain time - based on a doctor's prescribed order. If the nurse is late to work (or late back from a break) and a medication is not given on time, the patient may be placed at risk. In addition, other team members are relying on each other to be at work - they cannot care for the patient on their own. Punctuality is an important aspect of team work and personal professionalism.

Putting the patient first

No matter what we do in our work day, patients always come first. Any spare moment we have in our day should be given to directly caring for our patients or improving their environment. When we have spare time, we can use that to chat with the patients or offer ourselves to our managers or other team members (to see if we can help them with anything). Providing patient care also means giving attention to note-keeping and making sure we document everything that is required of us.

Actions and conduct should always be to ensure a patient's stay in a clinic or hospital is the best they can possibly receive, and that they are not worse-off on departure. Additionally it is important to ensure actions (or lack of actions) do not waste valuable time (and hospital money) by mis-treatment, neglect or error.

Nurses have always been patient advocates. Therefore it is important to alert senior nursing manager/s (or medical advisory committees, hospital managers or CEOs, if the nurse manager is directly involved in an incident) of issues which place the patient at harm or are outside of hospital policy and/or illegal activities. This is important for our own peace-of-mind as well as that of the patient and employer. It is then the responsibility of those senior staff members to investigate the reported issues, put in place mechanisms to prevent it in the future and to protect and thank the staff member for their initiative, and for drawing it to their attention.

Turning off mobile/cell phones

As a society, we are addicted to our phones and while smart phones do provide some valuable clinical applications, in general, if only used for personal use, they are not required when providing direct care to a patient. During work hours, personal phones should be turned off (or placed on silent) when in the presence of a patient or visitor. Texting and phone calls can be completed during break time. This is because phones are a distraction and could take the focus away from the patients. Using a phone for personal use may upset the patient or cause us to make a medical error. In some cultures, it can also be considered rude to answer the phone while working, or caring for, or talking to another person. This rule also applies when attending lectures and education events.

Caring for Ourselves

Healthcare professionals can often spend a lot of time caring for others that they forget to care for themselves. This could put their own health and safety at risk and could lead to a short-term or permanent inability to do their job (through injury or mental exhaustion). In the worst case scenario, this could result in a loss of income to support their family.

As modern life has society connected to the internet and the personal phones - and in turn work, nurses need to detach themselves and recharge their energy levels. Self-care may include:

Having an eye check-up

It is important to have eyes checked regularly. Many countries advocate for a regular eye check-up every 1 or 2 years, or more frequently if there is a known issue. Eye sight is important in order to perform several specialised tasks - be it reading labels on a drug bottle, seeing a suture when loading a needle holder, or guiding a vision impaired person. It is also an opportunity to set a good example to the patients with preventative check-ups.

Sleep

A good night's sleep is important. This means about 6-8 hours of solid sleep. It is particularly important for those on shifts (i.e. night duty) because sleep patterns may not follow a routine schedule. Some cultures also have midday sleeps (siestas) which are also good - as long as the hospital allows for this, and patient care is not compromised through this practice.

A good night's sleep will help to generate energy that is needed to perform daily tasks. It increases the brain's ability to focus on difficult and complex tasks and issues - which is extremely important for professionals who are responsible for the lives and eye-care of others.

Body care

Compliance with hospital policy regarding lifting and moving objects correctly is essential. If a part of the body is hurt/injured while at work (or when not at work) there is a risk of permanent injury - which could be painful and/or reduce our job options. Always follow workplace health and safety (occupational health) instructions and use any available device or equipment to help lift, guide or move objects or patients. There is a lot of information available on the internet that can explain proper body mechanics. For example, try and Google 'ergonomics' which is the study of the body's movement (this is also called Manual Handling in some countries). Tips include how to move correctly, prevent repetitive strain or prevent damage from continual lifting, prolonged computer use and other repetitive tasks.

Mindfulness

Scheduling some time to re-charge energy levels is also important. A process called mindfulness can do this. Mindfulness means focusing on what is happening right-here, right-now, by taking slow and deep breaths and letting go of stresses. This process can help calm the nerves. Some people can do this through private meditation on their own. Others can do this through attending a spiritual or religious event (i.e. Church, Temple or the Mosque), or by

simply taking a moment to stop, sit down in the fresh air and enjoy a nice cup-of-tea. It sounds simple, but that chance to take some nice slow breaths and remember what life is all about is very important. It will also help to focus, when caring for patients.

Hygiene

Showering/washing every day is essential. It is important that bugs are not carried on the body to and from the workplace and home. It also helps comfort levels and helps to prevent unnecessary smells – which can be offensive to the nose of other people. Many hospitals do not allow Operating Theatre (OT) clothes to be worn outside either, so check the policy regarding their dress-code and infection control practice.

Keeping fit

The human body is designed to move, so regular movement is encouraged. This could include, for example, a 30 minute walk to and from work, going to the gym, gardening or even participating in local sports or dancing clubs. Keeping fit will prevent injuries to the body. Movement has a direct link to mental wellbeing and provides a great opportunity to separate from everything else in our busy lives.

Eating well

Healthcare providers are notorious for grabbing quick snacks, missing meals and going without drinks for hours. This is not good, because they can become dehydrated and malnourished. It is important to eat healthy food and drink water regularly, throughout the working day.

Safety and security

Personal-safety is important if travelling to and from work, during an evening or night shift, when it is dark outside, or when working in a mobile facility. If leaving work in the dark, try and leave with someone else and walk together to the bus or car. Alternatively, if there is a security guard, ask them for assistance (i.e. escort). This is because, worldwide, hospitals are easy targets for crime, such as bag-snatching, or even worse, physical acts against another person.

Travel responsibly

If travelling is a major component of a job, where a lot of time travelling is required i.e. sitting down and not moving, changing time zones or working more than 8-10 hours a day on top of travel, then working out a wellbeing plan with family members and managers is essential. This is because, if not managed correctly, travel can harm home and work life causing disturbance of sleep or lack of sleep, inability to maintain a regular diet or fitness regime, and a lack of personal privacy to conduct personal rituals. This may result in weight gain, mental and physical patterns of fatigue and an inability to focus and complete work to the expected standard. Irritability is also a possible outcome.

Therefore, if travelling for work is required, ensure rest days are factored into rosters and that work loads are considerate of the need for personal, wind-down time. Another option is to discuss this with the Human Resource team (HR) – all good HR teams should be proficient in recognising these needs and working towards developing a long-term plan.

Maintaining a professional registration

It is important to find out the requirements of the local nursing council in order to maintain a nursing license. This may include ensuring competencies are retained in some key skill areas. Some hospitals also have formal competency programme to help staff to keep up their skills and license.

Additionally, finding out if there are nursing or technician associations, in the country or region is important. Joining such groups is a wonderful opportunity for learning. It is also a great way to meet other nurses and technicians who will become a valuable resource and a great professional friends. Please see the Appendix C for a list of some associations around the world.

Global Initiatives

There are several key initiatives which are the foundation of care for all health care providers. Global regulators and peers are encouraging health care providers to revisit these initiatives, implement them hospital wide and maintain them on a long-term basis. Below are some current global World Health Organization (WHO) initiatives.

5 Stages of Hand Hygiene Campaign

The WHO hand hygiene campaign is designed to raise awareness of the importance of hand washing and the changing of gloves to prevent the spread of infection. Through this initiative, 5 key elements have been described as 'Moments' when hands must be washed or gloves changed (Hand Hygiene Australia). These are:

- Moment 1 – Before touching a patient
- Moment 2 – Before a procedure
- Moment 3 – After a procedure or body fluid exposure risk
- Moment 4 – After touching a patient
- Moment 5 – After touching a patient's surrounding area.

Based on the 'My 5 moments for Hand Hygiene', URL: www.who.int/gpsc/5may/background/5moments/en/index.html World Health Organization, 2009.

5 moments apply to EVERYONE working inside the hospital.

Many national groups have also implemented an auditing system to help evaluate how effective hand hygiene is within a hospital or specific ward/department. This helps determine if more education or more resources are needed to improve hand hygiene practice.

Appendix B provides auditing tools from the organisation Hand Hygiene Australia. To learn how to use these audit tools, please visit the website: www.hha.org.au. The processes of auditing will also be discussed in section 9 of this text.

Medication Safety, Naming and Labelling (i.e. National Tallman) Safety Campaign

There are so many drugs on the market that it is often difficult to remember which to select. Additionally, their names can all sound the same.

As a result, health professionals can unintentionally administer the wrong drug. To prevent this, the WHO and several national bodies of some countries (i.e. the Commission on Safety and Quality in Healthcare in Australia) have implemented training materials and a national policy called the National Tallman Lettering system to help prevent medication errors.

National Tallman Lettering: This is a system in which drugs, with similar sounding (or spelt) names are grouped together to alert the person administering the medication that the names sound the same and they need to double-check. This prevents them from picking up the wrong drug. It works by applying a specific 'lettering' system to the label. This could be by a combination of tall or short letters - where the similar parts are capitalised. In Australia, it is recommended that pharmacists use this in their cataloguing

system. Pharmacists are also required to print the 'lettering' on the label to alert the health professional who is administering it.

Please ask a pharmacist for local information or please visit the Australian Commission on Safety and Quality in Healthcare website: www.safetyandquality.gov.au/our-work/medication-safety/safer-naming-labelling-and-packaging-of-medicines/national-tall-man-lettering/

Some helpful Tips on medications:

Always make sure drug labels are in a language that can be understood. If not – do not use.

Always remember to check that the drug being administered has been:

- stored correctly – to the correct temperature
- has not been tampered with
- has a label on it
- has not expired.

This includes viscoelastic, trypan (vision) blue and topical applications.

Always remember to:

Have dangerous drugs, such as morphine, antimetabolites/cytotoxics and anaesthetics, double-checked with another trained staff member.

Always check:

- The doctor has ordered the drug and it is written in the patient's chart or the OT standing orders.
- The order is correct for that intended patient (i.e. check that an adult dose is not administered to a child – you need to tell the doctor if there is an error so they can change the order).
- It is being given to the correct patient.
- It is being given at the correct time.
- The patient is not allergic.
- The correct drug type is selected from the drug cupboard (for example paracetamol can be administered oral or intravenously).
- The drug is prepared for the correct route (i.e. intravenously or intracamerally).
- The dosage/dilution is correct.
- Everything has been double-checked again before administering (i.e. by asking the patient to re-confirm their details and checking the patient identifiers).
- The patient is informed of what they will be given.
- The patient is monitored for adverse reactions post-administration.
- Anything that has been given is documented against the order
 - any controlled drugs are also documented in the controlled drug book.

Note: nurses must always stop and help another healthcare provider if they ask for assistance with double-checking a drug. This promotes a safe team culture and a safe work environment. Please ensure active participation in the checking process. (Australian Commission on Safety and Quality in Healthcare, 2016.)

Safe Site Surgery Checking Campaign

The concept of the Safe Site Surgery (SSS) checking system was launched by the WHO several years ago and has quickly gained global support from nurses, anaesthetists, ophthalmologists and many other members of the medical team. This is because SSS checking is considered to be extremely useful in preventing medical error such as injury or death. It is now considered as the 'gold standard' in preventative care, and should be implemented into every OT, and every procedure room in every healthcare facility. This system prevents harm to the patient and helps reduce the economic burden associated with rectifying (fixing) or compensating for the error. The system requires checking of patient details including patient identifiers – which we will discuss shortly. These checks, once completed are ticked and signed on a specific check sheet. Please see the check sheet example in Appendix B.

How it works

It basically works by healthcare professionals STOPPING what they are doing and focusing 100% on the patient at specific points in the patient's care. It requires participation from every member of the health care team, whereby they all work together- as equals, to put the patient's needs above and before all else. Team members need to be respectful of each other, remove barriers to communication and take equal team responsibility for the outcomes of the patient in front of them.

The 'specific' points in a patient's care plan (when these checks take place), are generally just before the commencement of an invasive procedure, however that does not mean the check approach cannot be adapted and used in other areas of healthcare. There are three specific points when the checks are done. These are:

Pre-operative – Sign-In (the first check)

- The pre-operative nurse does this check, followed separately by the anaesthetist (or anaesthetic nurse if there is no anaesthetist involved in the care).

Only after the pre-operative nurse and anaesthetist have completed their checks can the patient be transferred (moved) to the OT/procedure room.

Pre-surgery – Time-Out (the second check)

- This occurs inside the OT. To do this, all members need to be present. This includes the surgeon, surgical assistant, anaesthetist, anaesthetic nurse, and scrub and circulating nurse.
- This occurs BEFORE prepping and draping a patient (and before the commencement of a general anaesthetic for adult patients).
- Everyone must STOP what they are doing and focus 100% on the patient and the questions on the checklist.
- One member of the team will call out the questions on the SSS check sheet (and signs the form on everyone's behalf). Other members check and confirm via the patient chart and visual checks of the patient and the equipment and instruments prepared.

Note: the only time a SSS Check is done post-administration of a general anaesthetic is when dealing with a paediatric patient (child) as it can often be difficult to keep the child still for a prolonged period without causing anxiety. This is not universal practice so it is best to talk to the anaesthetic director – who is the knowledgeable expert in this area, and put in place a policy on how the hospital will handle the SSS check when caring for paediatric patients.

Post-surgery – Sign-Out (the third check)

- This check is completed by the OT scrub and circulating (scout) nurses only. They need to make sure that they complete the check prior to the surgeon closing the wound. They follow-up at the end, on any broken equipment that needs attention or withdrawal from service.

Patient identifiers

The SSS check system requires the team to cross-reference against 'Patient Identifiers' (PI). These are known details about the patient, which helps to distinguish patients from one another. This is especially important in communities with similar sounding names. Generally it is preferred that – at the least – no less than 3 PI are used in a check system. Some commonly used PIs are:

- name – and spelling
- gender
- age or date of birth (if known)
- home address
- home phone number
- procedure Information, i.e.
 - name of their doctor
 - hospital identification number
 - type of surgery/procedure
 - location (site) of the surgery (i.e. the left eye or the right eye)
- personal medical and surgical history
- allergies.

These can be checked against several key items, i.e.

- surgical schedule list
- patient consent
- patient chart
- surgeon's chart/notes
- patient or family member's verbal confirmation of the details.

If there is a discrepancy, in any or all of these items, then there is reason to STOP and address before proceeding with care.

Identification bands

In many parts of the world, once the patient's identity has been confirmed, they are given a hospital identification band. They must wear this for the duration of their stay. Depending on resources, the identification band can be placed on the wrist or ankle via a waterproof wrist band or by an adhesive sticker placed onto the patient's gown. Regardless of which method is used, they are fundamentally the same but will only work if there is a policy in place that ensures staff routinely place the name tag in the same place for every patient (i.e. – always the left wrist, or a sticker is always placed on the right shoulder-breast region) every time. Another widely used system is to use a different colour band or sticker for patients with an allergy or medical issue – or alternatively they get two bands.

Tip: When writing details on identification bands, make sure the information is not too personal, as it is important not to advertise a patient's private business.

WHO. Guidelines for safe surgery: safe surgery saves lives. (2009). www.who.int/patientsafety/safesurgery/en/

Antimicrobial Stewardship Campaign

The term 'Antimicrobial Stewardship' is an English-speaking term which simply means that health care providers need to put in place a plan to guide (which, in English, can also be called Steward or Stewardship) and encourage better prescription and use of antibiotics and antimicrobial agents.

This is because around the world, antibiotics have been over prescribed to such an extent that many people are becoming resistant to even some of the stronger antibiotics. Thus when a serious infection (i.e. a virus) enters their body there will be nothing to stop it. This could lead to a greater spread of the disease in the community, and is often termed as Multi-Drug Resistance. While this is currently an issue facing higher resource countries, the WHO and experts who specialise on the immune system, drug resistances and the spread of diseases are concerned that in time this may also impact lower resource countries and become a global endemic issue. These specialists are recommending a Stewardship Programme be put in place by healthcare workers to prevent the over-prescribing of medications.

While the world wants to prevent the spread of infections, there is also a need to reduce the associated healthcare costs for patients who are resistant because they have to stay in hospital longer (McKenzie et al, 2013). Experts are suggesting that a plan should include:

- checking the quality of the drug
- putting in place prevention of over-subscription (i.e. can the patient be given a non-drug treatment option).
- training health workers on the risks of cross-contamination to prevent spread.

For further information

- WHO Policy Package to Combat Antimicrobial Resistance: www.who.int/bulletin/volumes/89/5/11-088435/en/
- McKenzie, D. Rawlins, M., & Del Mar, C. (2013). Antimicrobial Stewardship: What's it all about? www.australianprescriber.com/magazine/36/4/116/20
- Mt Saini University Hospital (USA). Antimicrobial Stewardship Program: www.antimicrobialstewardship.com (home page)

Inclusive Disabilities Campaign

In our efforts to develop high quality clinical practice it is important not to overlook the wider needs of people with all types of disabilities, including those with vision impairment. It is important that we consider ways to strengthen our practice and ensure we are making all people welcome and particularly ensuring we are including people with disability. These practices will also help us to be more inclusive generally.

This is why an inclusive approach to including people with a disability is important:

- People with disability, including those with vision impairment, form the world's largest minority group, comprising 22% of the world's poorest people. (World Health Survey, 2002-2003.)
- There is a strong correlation between disability and poverty, with poverty leading to higher rates of disability and disability increasing the risk of poverty. (International Classification of Functioning, Disability and Health, 2001.)
- Women and girls with disability may face triple discrimination: being female, having a disability and being among the poorest of the poor. (Elwan, 1999.)

- 'Disability' is about much more than 'impairment'. Disability is created when a person with impairment interacts with socially imposed barriers which limit their functioning. (International Classification of Functioning, Disability and Health, 2004.) People with disability report multiple barriers to accessing health services. (Drainoni et al, 2006.)
- Many people with disability, including those with vision impairment, experience exclusion, stigma and discrimination, especially in relation to possible false beliefs about the causes of their impairments and their capacities. (Ingstad and Whyte, 1995.)
- Address cost barriers to treatment, transport and accommodation for people with disability, and where relevant, for accompanying persons.
- Work with people with disability to identify and address physical accessibility, including access to the OT and prep rooms. This will include ramps, hand rails, wide doorways and clear markings on the floor; accessible toilets with door pull straps, 'grab' rails, and a low-level wash basin; consultation rooms with enough space for a wheelchair to turn freely; mounting of slit lamps and other equipment to allow full access for a wheelchair user; and place stickers over glass doors and walls so vision impaired patients can prevent walking in to them.

Barriers to access, and other difficulties faced by people with disability

The barriers to access, faced by people with all types of disabilities, including vision impairment, may be due to community attitudes, lack of awareness or training of personnel, physical surroundings, financial and transport limitations, communication problems, and laws and policies. (Swain, 2004.)

In most settings, staff who work in the OT have a vital role in creating community awareness and providing access during all phases of patient care. This helps promote and foster a caring and collaborative environment within their eye health service, and seeks to provide improved outcomes for this group of patients.

Strengthening practices to be more disability inclusive

The best way to put in place better practices is to consult with colleagues and with the patient. This can be supported with appropriate hospital policy and the encouragement of a positive culture to care for all patients. It might also be beneficial to work with community groups who may be able to provide recommendations to improve service. The following checklist should also help the eye service and OT on the journey to better inclusion.

- Put in place a hospital-wide policy which outlines the expectations of the hospital in managing and caring for all patients. Include in the policy:
 - an outline of the objective for disability inclusion in your facility: e.g. a) to ensure practices are inclusive of women and men, boys and girls from all disability groups, including vision impairment, with particular regard to mobility needs; and b) that patients whose sight cannot be restored, receive counselling in order to access their right to wider opportunities in education, livelihoods and social inclusion
 - clear links with other policies on gender and child safeguarding
 - the need to foster a safe and welcoming environment for all people of any age, gender, disability, ethnic group, religion, poverty level and sexual orientation.
- Actively engage with Disabled Peoples Organisations (DPOs) to develop specific actions for improved inclusion. Employ people with disability and include their views into the functioning of the eye health service and OT.
- Train personnel in practical disability inclusion, for all parts of the facility, including the OT.
- Appoint a staff member as Disability Inclusion Officer, as part of an existing staff role or in a dedicated position. Support this person with a Disability Inclusion Committee, empowered to enact change and support hospital wide policy and culture change.
- Strengthen all networks for disability inclusion with mainstream and disability-specific services such as Community Based Rehabilitation (CBR), Primary Health Care, education and employment facilities - both government and non-government.

- Ensure that all signs are preferably between 1m and 1.5m from floor, of good colour contrast and in a large, clear print. Use clear symbols, as well as writing.
- Modify methods of communication to ensure all people are able to understand. This is particularly important before and during surgery, and especially relevant to people with vision, hearing or intellectual impairments, and children and elderly people.
 - i.e. for vision impaired patients, ensure information sheets are written in a large and simple font and appear as dark letters on a light background.
- Be patient and respectful with people with psycho-social or intellectual disabilities, and ask if they would like someone to support them during surgery.
- If there are concerns that people with certain disabilities may become agitated during surgery, restraining them should be a last resort. Instead consider assistance from family members and possibly alternative forms of anaesthesia.

Training programmes that can help health care providers support patients in their care

Consider learning:

1. How to guide a person with vision impairment - this is essential for all staff in eye care facilities.
2. How to care for persons who need mobility support without harming the patient or self - this is called Manual Handling.
3. How to position a patient for surgery without undue restraint.
4. Deaf sign language - for example, in the ophthalmology outpatients department at Groote Schuur Academic Hospital in South Africa, professional sign language interpreters are rostered on a designated day each month, for people who are deaf or hard of hearing. This programme respects the fact that eye sight is extremely valuable for people who are deaf and dependent on sign language for communication. A key strength of the programme is its consultation and partnership with local DPOs. An added benefit is the employment of people who are deaf or hard of hearing. These personnel not only contribute to the workforce, they also bring specific knowledge of strategies, to engage the local community members who are deaf or hard of hearing to come to the service for vision screening. This project has resulted in a monthly, mobile phone text message promotion, to a growing data base of people in the deaf community. In addition, personnel, who are themselves deaf or hard of hearing, meet and greet new patients and assist the interpreter throughout the visit. These patients are supported during consultations, procedures and in the OT during surgeries. The work of this programme also encourages and models strong inclusive practice for patients from all disability groups.

For further information

- CBM. Inclusion Made Easy in Eye Health Programmes. Disability-inclusive practices for strengthening comprehensive eye care. www.cbm.org/disability-inclusive-eye-health.

References

1. Australian Commission on Safety and Quality in Healthcare. National Tall Man Lettering. www.safetyandquality.gov.au/our-work/medication-safety/safer-naming-labelling-and-packaging-of-medicines/national-tall-man-lettering/ Accessed 26/05/2016.
2. Drainoni, M, L, Lee-Hood, E, Tobias, C, Bachman, S. S, Andrew, J., & Maisels, L. Cross-Disability Experiences of Barriers to Health-Care Access: Consumer Perspectives. *Journal of Disability Policy Studies*. 2006; 17(2): 101–115.
3. Elwan, A. Poverty and Disability: A survey of the literature. Social Protection Advisory Service.
4. Ingstad, B., and Whyte, S. R. (1995). *Disability and Culture*. Berkeley: University of California Press. California. 1999.
5. McKenzie, D, Rawlins, M., & Del Mar, C. Antimicrobial Stewardship: What's it all about? *Australian Prescriber*. August 01, 2013. www.australianprescriber.com/magazine/36/4/116/20. Accessed 05/26/2016
6. Swain, J. *Disabling Barriers – Enabling Environments* 2nd ed. 2004. London: SAGE.
7. World Health Organization. *International Classification of Functioning, Disability and Health (ICF)*. 2001. Geneva: WHO.
8. World Health Organization. *Guidelines for safe surgery: safe surgery saves lives*. 2009. www.who.int/patientsafety/safesurgery/en/. Accessed 26/05/2016
9. World Health Organization. *International Classification of Functioning, Disability and Health (ICF)*. 2001. Geneva: WHO.
10. World Health Organization. *My 5 moments for Hand Hygiene*. 2009. Geneva: WHO. www.who.int/gpsc/5may/background/5moments/en/index.html. Accessed 26/05/2016
11. World Health Organization. *World Health Survey. (2002–2004)*. Geneva: WHO.
12. World Health Organization. *Universal eye health: A global action plan 2014-2019*. 2013. Geneva, WHO. www.who.int/blindness/AP2014_19_English.pdf?ua=1. Accessed 26/05/2016

SECTION 2

Ocular Conditions Requiring Surgical Treatment.

Contributors: Hunter Cherwek, John Cooper, Kristen A Eckert, Heather Machin, Ingrid Mason, Neil Murray, Heiko Philippin, S. Grace Prakalapakorn, Van C. Lansingh and the Aravind Hospital Team: Indira Durai, Namratha Gaikwad, Deeba Ishrath, Dr.Jyothirathod, Usha Kim, A.Karthik Kumar, Vrushali Patil, R.Sharmila, and Sr.Sundari



The surgical nurse and technician are key members of the surgical team and need to be engaged in the management of the Operating Theatre (OT) services at all times. Those involved in the direct care, also need to be trained and experienced with the techniques, complications and resources required during surgery. This section will provide an explanation of some ocular conditions that commonly require surgical treatment, followed by an explanation of what is involved in the treatment. It will also outline some instruments and equipment that are routinely required and commonly found around the world. These are not exhaustive lists because each hospital and surgeon may perform the surgeries slightly differently and for different reasons. Therefore, it is important to communicate clearly with the surgeon before starting the surgical list to make sure everything is ready - and within the policies and rules of the facility.

Note: This section will exclude anaesthetics. This will be covered in Section 4b. Surgeon Preference Card template are also available in Appendix B. This can be completed for each surgeon to help the team prepare the OT each day.

Anatomy Diagrams

Diagram 2.1: The globe and surrounding tissue

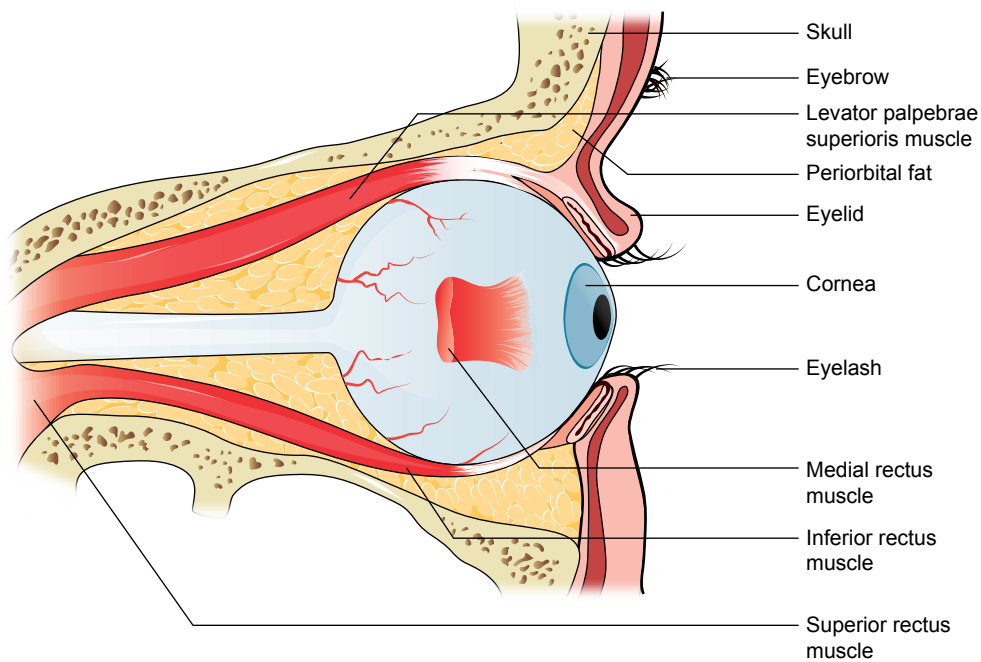

Image source: Lions Eye Donation Service

Diagram 2.2: Cross-section of the anterior aspect of the eye

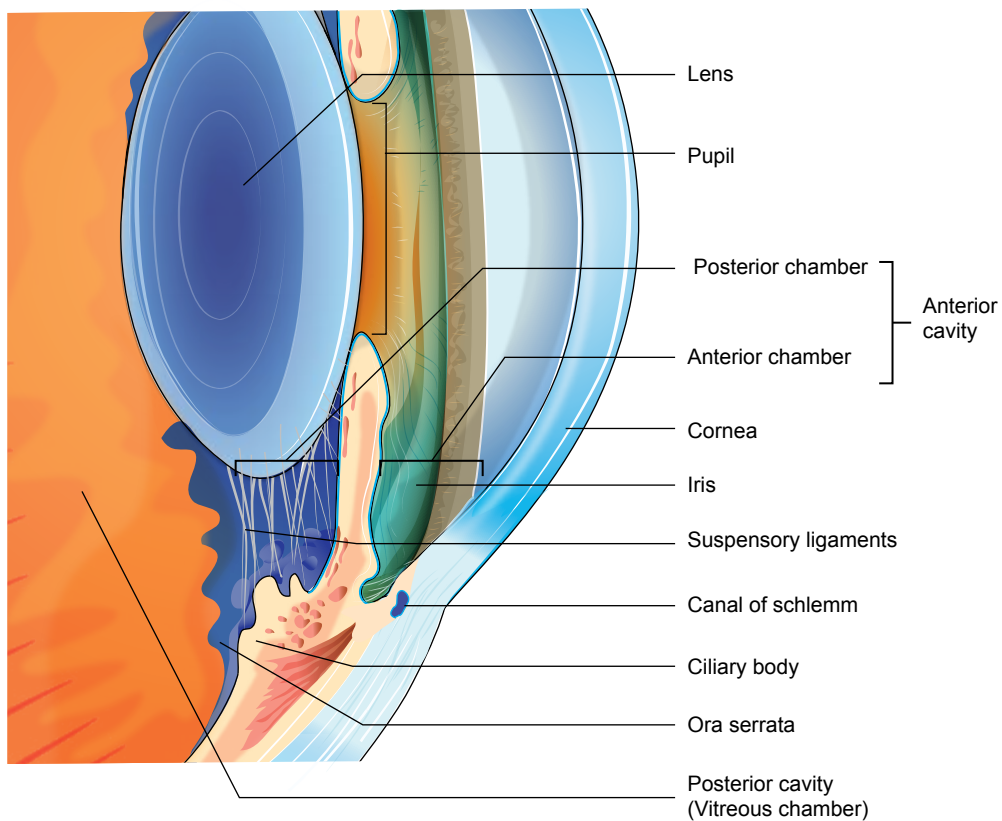

Image source: Lions Eye Donation Service

Diagram 2.3: Layers of the cornea

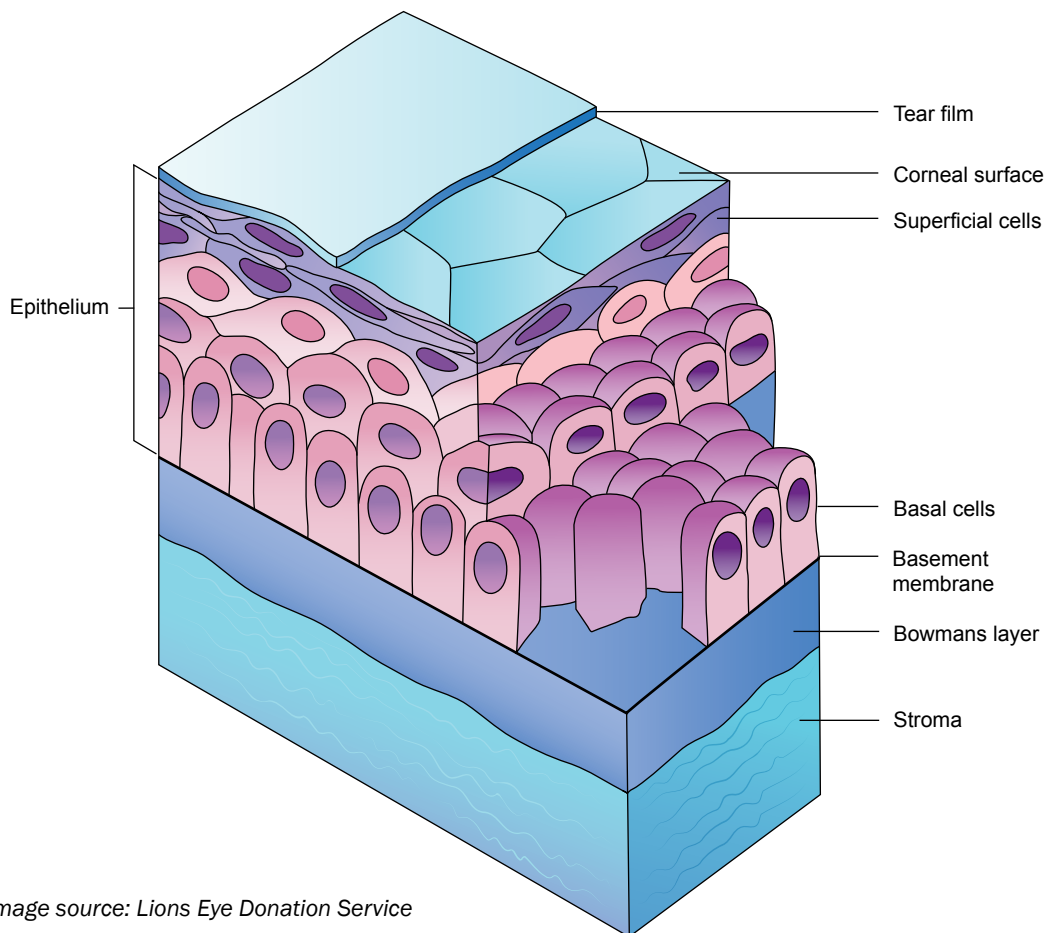

Image source: Lions Eye Donation Service

Cataract

Ingrid Mason, Neil Murray and Heiko Philippin

Name of eye disease: Cataract - opacity of the crystalline lens (mainly age related but also can be congenital and traumatic).

Surgical intervention happens when the patient's vision is compromised by the clouding of the natural crystalline lens inside the eye. The patient can no longer enjoy or safely perform the activities of daily living, due to the quality of their vision. This can include working, driving, reading, or watching television and may be worse at night due to glare. Surgery is performed to remove the cataractous lens and implant an intraocular lens (IOL), ideally in the capsular bag.

Prevalence

In 2015, cataract remained the world's leading cause of blindness, accounting for just over half of the world's blind cases. As cataracts can be cured with surgery they have been a leading focus of blindness treatment around the world. When the global initiative called VISION2020 started in 1999, with the aim of eliminating avoidable blindness by 2020, cataract surgery was often performed with an extracapsular (ECCE) technique (or sometimes intracapsular (ICCE) technique) - with or without a standard strength intraocular lens (IOL), and often with little regard for quality outcomes. Mainly, because of VISION2020, the tide is now turning. The most recent data (2010) suggesting that despite the world's population aging and increasing by almost one third between 1990-2010 (5.3 to 7 billion), that the absolute number of people who are cataract blind has not increased. Today most developing world cataract surgery is performed with the Small Incision Cataract Surgery technique (SICS), using a customised strength of IOL. The quality of the outcomes is comparable to those from the higher resource locations.

This section will examine the various types of surgical technique, including SICS, ECCE, ICCE and Phacoemulsification (Phaco).

Note: for the purpose of this text, a technique called Femtosecond Cataract Surgery is excluded however readers are encouraged to explore this newer technique should they wish. Additionally, paediatric cataracts will be discussed within the paediatric section rather than this general adult cataract section.

Important acronyms needed to understand this section:

- AC – Anterior Chamber
- PC – Posterior Capsule
- IOL – Intraocular Lens – which is inserted to replace the cataractous lens
- IOP – Intraocular Pressure.

Pre-operative management of cataract patients

- Pre-operative care includes anaesthesia, antiseptic wash and dilating drops.
- The patient should be reminded of the importance of holding still during surgery.
- The choice of anaesthesia is largely determined by the status and cooperation of the patient and can include topical, intracameral, peribulbar or retrobulbar injections ('blocks'), sub-tenon, and general anaesthesia.
- It is important to monitor the patient's vital signs during surgery.

Post-operative management of cataract patients

- Provide instructions on the post-operative drop regimen (usually consisting of a topical steroid and antibiotic), eye protection (including eye patch and shield), and signs and symptoms to report especially worsening pain and redness.
- Follow routine post-operative instructions for surgery and anaesthetic – see section 4b which will discuss the duties of the recovery and discharge team.

Implant - IOL

- The IOL is a component of the cataract procedure. The patient's eye should be properly measured before surgery. This process, called biometry, measures two critical values of each patient's eye - the axial length (by an A-Scan ultrasound or infrared interferometry) and the curvature of the cornea (so called K's measured by a keratometer) (See Section 4a for more information on Biometry). This data is then used in one of several mathematical formulas (e.g. SRK-T) to calculate the appropriate IOL strength (power) in dioptres. It is critical for the type of IOL being inserted that the correct A-constant (usually found on the IOL box, or the surgeon may have their own "personalized" A-constant) is used in the mathematical formula calculation.
- Make sure the correct IOL is confirmed during Sign-In and Time-Out.

Medications/solutions

Check with the surgeon before administering (note: label all syringes on the surgical table, and always handle and pass the syringe in a safe manner):

- topical dilating drops
- capsular dyes (for example, trypan blue)
- topical antibiotic drops
- topical steroid drops and possible non-steroidal anti-inflammatory drops (NSAIDs)
- injectable antibiotic and dexamethasone at the end of the procedure
- viscoelastic or Ophthalmic Viscoelastic Device (OVD)
- balanced salt intraocular irrigating solution (e.g. BSS, lactated Ringers)
- injectable miotic solution (e.g. Miochol/miostat) to constrict the pupil.

Scrub nurse duties

- Participate in the SSS check – including IOL and biometry checks.
- Prep and drape the patient and ensure that a sterile technique is maintained.
- Keeping the cornea surface well lubricated so that the surgeon has a clear view – this is achieved by placing balanced salt solution in a syringe and dropping onto the cornea periodically until the IOL is inserted. It is important, at all times, not to block the surgeon's view especially when the capsulorhexis is being performed or when the lens is being inserted. Once the IOL is in place this can be stopped – unless instructed to do so. This allows the surgeon to check and see if the wound has closed.
- Ensure there is a sterile anterior vitrectomy cutter on stand-by.

SICS Technique

Full name: Small Incision Cataract Surgery with Posterior Chamber IOL Implant (SICS + PC IOL) (also known as Manual small incision cataract surgery - MSICS).

Surgical technique

A self-sealing corneoscleral tunnel incision (wound) - is created with either a superior or temporal approach. A separate side-port (paracentesis) incision(s) is often created. The AC is stabilised with viscoelastic. The anterior lens capsule is opened using a bent 25 or 27 gauge needle or capsule forceps by linear, V, can-opener capsulotomy or continuous curvilinear capsulorhexis (CCC). The cortex and the nucleus (central portion of the lens) are then separated by hydrodissection. The nucleus is removed through the tunnel using one of several techniques. The cortical material is then aspirated using the Simcoe cannula and the balanced salt intraocular solution. Simultaneous irrigation and aspiration maintains the AC and protects both PC and the corneal endothelium from damage. The aspirating tip of the cannula must face uppermost. A Posterior Chamber (PC) IOL is then inserted into the capsular bag with viscoelastic maintaining the AC. The viscoelastic is then removed, and the wound self-seals without sutures. The surgeon may choose to insert one or more sutures. Antibiotics are injected, usually into the AC, but at times subconjunctival and often with steroids. The final stage involves checking for any wound leakage and confirming that the AC is deep with a round pupil and centred IOL.

Duration of procedure: 30 minutes

Complications at time of surgery

Vitreous loss with capsular rupture - The vitreous moves into the AC and incision, because of a rupture or break in the PC.

Causes

- excess local anaesthetic or retrobulbar haemorrhage causing increased pressure in the eye
- previous eye trauma causing zonular weakness
- anterior capsule tear extending to the PC
- traumatic or difficult lens expression with zonular dehiscence
- if the aspirating tip of the Simcoe cannula is not maintained in the correct position, or it enters too deeply, the PC can be torn. This may result in vitreous loss
- inadequate anaesthesia: the eye moves making lens removal very difficult.

The vitreous must be cleared from the incision and the AC. If it remains in the incision it can result in:

- retinal detachment
- macular oedema
- endophthalmitis
- secondary glaucoma
- distortion of the pupil
- photophobia
- corneal oedema

Management

Anterior vitrectomy - An automated vitrectomy machine cuts and aspirates the vitreous whilst maintaining the depth of the AC.

Alternatively, a manual vitrectomy with De Wecker's scissors (or other intraocular scissors like Vannas) and small non-lint cellulose swab can be used. The process being:

- The swabs are used to engage the vitreous in the incision and AC.
- Vitreous strands adhere to the swab and are cut with the scissors.
- Initially the incision edge is cleared followed by the anterior chamber, by gently inserting the swab through the incision in the AC, to then engage and cut the vitreous.
- An iris spatula can be used to sweep the wound from a side-port incision (paracentesis). This can assist in clearing the wound, and may release vitreous traction, allowing the vitreous mass to drop posteriorly. The vitreous strands must be manipulated gently and not pulled out, as this may cause detachment of the retina.

Regardless of the technique used, the surgical aim is for an adequate clearance of vitreous, indicated by a round pupil with the use of a miotic after the anterior vitrectomy. Air may also be injected into the AC to help push any remaining vitreous posteriorly. Air also aids in determining the presence of any remaining vitreous in the AC. If available, triamcinolone is very useful when injected into the AC. It will adhere to and highlight any remaining vitreous. Any retained vitreous in the AC or in the wound can cause a distorted pupil.

Expulsive haemorrhage - Expulsive haemorrhage is a very rare occurrence in which the choroid starts to bleed profusely at any time when the wound is open. It is often associated with an excess volume of local anaesthetic, retrobulbar haemorrhage, patient coughing, hypertension or prolonged surgery. This is an emergency situation.

Management

The wound must be sutured immediately to stop the bleeding. By closing the eye, the IOP is restored and the bleeding is reduced. If it is not possible to suture the eye, an evisceration may be necessary.

Early post-operative complications (in no particular order) may include:

Raised intraocular pressure (IOP)

Signs

- pain
- nausea and vomiting
- reduced visual acuity
- hazy cornea.

Causes

- Inadequate irrigation of viscoelastic from the AC after the insertion of the lens. The viscoelastic must be completely removed at the time of surgery otherwise it can cause raised intraocular pressure.

Management

- Topical and oral medication (e.g. Timolol and Diamox) to lower the IOP. If no improvement within two days, the remaining viscoelastic must be surgically removed from the AC.

Leaking wound

Signs

- shallow or flat AC
- aqueous fluid leakage from the wound, seen on slit lamp examination (seidel test positive)
- poor vision.

Causes

- patient rubbing eye after surgery
- excessive coughing or bending
- poor incision construction, resulting in an inadequate seal of the wound.

Management

The patient needs to be returned immediately to the OT for suturing of wound and reforming of the AC.

Duration of procedure: 30-45 minutes

Iris prolapse

The iris can prolapse either from rubbing or injuring the eye, or through a poorly constructed wound. The prolapsed iris causes aqueous fluid to leak out with subsequent shallowing of the AC.

Signs

- iris is pulled up towards the wound
- iris is present under or in front of the conjunctiva
- pupil is pear shaped or 'peaked' towards the leak.

Management

The patient needs to be returned immediately to the OT for repositioning of iris, reforming of the anterior chamber and suturing of wound.

Duration of procedure: 30-45 minutes

Endophthalmitis

Endophthalmitis is an intraocular infection occurring within six weeks of intraocular surgery. Please see section 3 for further information.

Signs

- pain
- loss of vision
- cloudy cornea
- hypopyon
- uveitis.

Causes

- lack of or inadequate perioperative asepsis with povidone iodine 5% preparation
- no intraocular antibiotic at the end of surgery
- wound leak
- ruptured PC with incomplete clearance of vitreous from the AC
- vitreous wick syndrome
- dacryocystitis
- conjunctivitis or blepharitis.

Management

Follow the guidelines of Endophthalmitis Management outlined in section 3.

Corneal decompensation

Sign

- Early onset reduced visual acuity with a hazy cornea and normal IOP.

Cause

- Damage is caused to the endothelium during the operation, often due to the AC not being sufficiently deep during insertion of the IOL.
- Poorly positioned IOL causing ongoing damage.

Management

- Consider removing the IOL.

Duration of procedure: 30 minutes

Retained lens material in the anterior chamber

Signs

- uveitis
- flocculent material in the AC
- hazy cornea
- raised intraocular pressure
- poor vision.

Cause

- Capsule rupture with incomplete clearance of lens material.

Management

Carefully clear all retained lens material and capsule, with particular attention to avoiding any vitreous loss. Alternatively, if stable, wait for 2-5 days, treat with intensive topical steroids and watch for severe uveitis and raised intraocular pressure. If these occur proceed to surgical clearance.

Duration of procedure: 30 minutes

Hyphaema

Hyphaema is the accumulation of blood in the anterior chamber which can vary from a couple of millimetres, up to completely filling the chamber (eight ball hyphaema).

Causes:

- usually bleeding from the wound incision
- less frequently bleeding from iris trauma
- rarely, the patient is taking anticoagulants or has a bleeding disorder.

Management

Hyphaema increases the IOP. If untreated for more than 5 days it can cause reduced vision from blood staining of the cornea and glaucomatous optic neuropathy.

- If the IOP is normal and the hyphaema is small, it should settle but with frequent regular follow-up assessments until the hyphaema has gone.
- Always check that the patient is taking anticoagulants or has a bleeding disorder and if so, take appropriate measures.
- Encourage the patient to sit upright especially during the day

as this helps with drainage of the hyphaema.

- If the pressure is high then medical management (see raised IOP) is indicated initially.
- If this is unsuccessful after 1-2 days, then surgery to evacuate the hyphaema, using a Simcoe cannula on an infusion, through a suitable sized side-port incision, is indicated.

Duration of procedure: 30 minutes

Late complications after surgery may include

Posterior capsule opacification

Proliferation, and sometimes pearly (grouping together), of remaining anterior capsule cells, causes capsular haze and reduced vision. To reduce the risk of this late complication, an ECCE should ideally be performed with a PC IOL implantation because of the high rate of posterior capsular opacity (secondary cataract) if no IOL is inserted.

Management

- Thorough removal of all lens material in the visual axis by YAG laser capsulotomy (if available) or pars plana needle capsulotomy.

Duration of procedure: 15 minutes

UGH syndrome

UGH refers to a low grade, chronic presentation of Uveitis, Glaucoma and Hyphaema. It presents with:

- cells in the AC
- pain
- endothelial deposits (pigmentary)
- raised IOP
- incarcerated iris noted on gonioscopy.

Cause

- Chafing of the iris by the IOL, due to a poorly sized or positioned IOL.

Management

- Repositioning or removal of the IOL.

Duration of procedure: 30 minutes

Cystoid macula oedema

Painless reduction in vision some weeks or months after cataract surgery. Cystoid macula oedema is macula swelling.

Cause

- It is more common after complicated surgery with vitreous loss and vitreous wick syndrome with an associated iritis.

Management

- 3-6 months topical steroids and nonsteroidal anti-inflammatories
- surgical revision of vitreous wick syndrome.

Duration of procedure: 60 minutes

Late corneal decompensation

Late onset reduced visual acuity with a hazy cornea and ocular surface discomfort.

Cause

- Permanent damage is caused to the endothelium during the operation, more often seen following complicated surgery.

Management

- Corneal grafting surgery is usually required to restore corneal clarity.

Retinal detachment

The retina detaches from the retinal pigment epithelium with symptoms of floaters, flashes, an enlarging visual field defect and loss of vision.

Cause

- Usually due to vitreous traction (rhegmatogenous) particularly when there has been complicated surgery with vitreous loss. More common in myopic patients.

Management

- Surgical repair with retinal detachment surgery.

ECCE Technique

Full name: Extracapsular Cataract Extraction with Posterior Chamber Intraocular Lens Implant (ECCE + PC IOL).

Surgical technique: A wide corneal or scleral incision is made. Viscoelastic is injected into the AC. The anterior lens capsule is opened, by using a bent 25 or 27 gauge needle to complete a linear, V-shaped, can-opener capsulotomy or continuous curvilinear capsulorhexis (CCC). The cortex and the nucleus are separated from each other by hydrodissection. The nucleus is expressed first. The cortical material is then aspirated using the Simcoe cannula. Simultaneous irrigation and aspiration maintain the AC and protect both the PC and the corneal endothelium from damage. The aspirating tip of the cannula must face uppermost. A PC IOL is then inserted into the capsular bag and the wound sutured. Antibiotics are injected and a final inspection is made of the wound, checking for leakage, and of the AC to confirm it is deep with a round pupil.

Duration of procedure: 30 minutes.

ICCE Technique

Full name: Intracapsular Cataract Extraction (ICCE)

Surgical technique

ICCE refers to the removal of the entire lens, within its capsular bag, by cryoextraction, manual expression or forceps.

Duration of procedure: 30 minutes, but any complication will lengthen the time of surgery.

Intraoperative complications unique to ICCE:

Capsule rupture

The outer covering (capsule) of the lens breaks, requiring separate removal of the nucleus from the capsule. Lens material and capsule can be left behind in the eye.

Management

- Washout and remove lens material by gently irrigating the AC with a Simcoe cannula or similar. This is an unplanned ECCE.

Iridodialysis

Occurs when the iris is separated from its root and insertion into the scleral spur.

Cause

When extending the incision into the AC using the corneal scissors, the iris root is accidentally cut or torn. The iris root often bleeds profusely.

Management

- it is not possible to cauterize the iris
- irrigation of the AC is necessary using the Simcoe cannula to stop bleeding
- air and viscoelastic may also be used to tamponade the bleeding
- the iris should be sutured with 10/0 Prolene if possible
- if possible, all the blood should be removed, as later complications, e.g. uveitis, raised IOP or a hazy cornea, may occur.

Phaco Technique

Hunter Cherwek

Full name: Phacoemulsification

Surgical technique

The term phacoemulsification ('phaco') refers to the removal of the lens using ultrasound. A small corneal or corneoscleral incision allows the phaco hand-piece instrument to enter the AC and simultaneously emulsify and remove the lens material from the eye. A phaco machine requires a single use changeable bag/cartridge system. Once the lens has been emulsified and completely removed, the surgeon places a foldable PCIOL into the eye. While this technique is more costly, it is a small sutureless (self-sealing wound) technique which allows for a quicker recovery from surgery.

Set-up items specific to Phaco

Machines

- **Phaco** - Ensure the phaco machine is properly maintained and the hand-piece has been sterilized. It is important that the entire team are aware of the surgeon's preferences for machine parameters, for each step of the procedure. Often, these parameters can be set for different "modes" or steps in the procedure and profiles can be made for different surgeons using the same machine.
- **Bipolar cautery** - sometimes used when scleral incisions are made.

Consumables

- Phaco packs – which include the tubing and tips that need to be connected to the machine and the phaco hand-piece. Every machine has a unique pack.
- Phaco tips and sleeves- Each machine has a variety of tips and sleeves to place onto the Phaco hand-piece. The nurse needs to check that the correct ones have been selected for

the operating surgeon (i.e. a 45 degree tip, a bevelled tip etc.).

- Foldable PC IOL with injection cartridge and injector/or PC IOL folding and insertion forceps.
- Viscoelastic/Ophthalmic Viscoelastic Device (OVD).
- Balanced salt irrigating solution (e.g. BSS, Lactated Ringers).
- Automated anterior vitrector should be available on standby should a posterior capsular rupture occur.

Instruments

- keratome knife(s) (sometimes a diamond knife)
- Capsulorhexis Forceps
- cystitome 27G pre-curved
- iris retractors
- nucleus rotator and/or Sinsky hook
- phaco chopper instrument
- bi-manual or coaxial irrigation and aspiration system.

Nursing considerations

There are common routine items that the nurse needs to have ready, to hand to the surgeon. The procedure should be broken down into the following steps so that the right consumable/instruments are ready:

- wound construction - includes proper handling of the blades
- viscoelastic/OVD injection with Rycroft cannula
- continuous Curvilinear Capsulorhexis (CCC) - can be performed with a bent needle (cystitome) or with forceps
- hydrodissection - a cannula is inserted between the lens capsule and lens cortex and a fluid injected to separate them
- nucleus rotation - helps ensure nucleus mobility for later steps of the procedure
- nucleus disassembly - can be done by a variety of methods including divide and conquer or various chop techniques
- cortex removal - with bimanual or coaxial irrigation/aspiration
- IOL Injection - a foldable IOL is injected through the main wound into a capsular bag filled with OVD
- wound check and final inspection - it is critical to check all wounds for any leakage and confirm that the AC is deep with a round pupil, and centred IOL.

Surgical complications

Similar to those already outlined for other cataract surgery techniques – rupture of the PC is possible. Vitreous loss in particular is also possible in Phaco surgery. The nurse needs to have the anterior vitrector machine and appropriate consumables on stand-by.

A "dropped nucleus" is more common in phaco. It is a serious complication which requires vitreoretinal surgery.

Glaucoma (Trabeculectomy)

The Aravind Hospital Team

Name of eye disease: Glaucoma

Definition

Glaucoma refers to a series of conditions which consist of increased pressure within the eye (Intraocular pressure or IOP), abnormal visual fields, and optic nerve damage. While an increased IOP is one of the hallmarks of glaucoma, there are cases where IOP is within the theoretical range of normal, but it is still too high to maintain a healthy nerve. Such cases are known as low tension glaucoma. If left untreated, glaucoma can lead to severe visual disability and even complete blindness. Glaucoma is often called the 'sneak thief of sight' because it is undetectable in the early stages. Therefore, regular eye examinations can help to manage the condition or prevent it from progressing. Glaucoma, which is also passed on through families can be treated at the clinic level through the prescription of eye drops to prevent the pressure build up.

Specifically, glaucoma is caused from a blockage in the eye's drainage system – called the trabecular meshwork, whereby aqueous humour cannot drain away – thus causing a build-up in pressure. If the condition progresses and cannot be controlled at clinic level, the surgeon may advise that the patient undergoes a surgical procedure to remove the blockage – thus allowing drainage to occur and pressure to return to as normal a state as possible. The general procedure is therefore a Trabeculectomy – meaning removal (ectomy) of a part of the trabecular meshwork, by literally punching a hole through it. There are variations to this procedure, i.e. using antimetabolite/cytotoxics or valves, and will be explained within this section.

Pre-operative preparation

- constrict the pupil.

Surgical technique/description

The aim of a Trabeculectomy is to establish aqueous flow from the anterior chamber (AC) to the sub-conjunctival space. This is achieved by making a conjunctival flap (flap) which may be either limbus based or fornix based, depending on the preference of the surgeon. This is followed by a partial thickness, scleral flap, similar to a trap door, and then punching through the trabecular meshwork with a punch (i.e. a Kelly's Punch). In more specific detail, the technique is:

- Complete Time-Out and prep the patient.
- Make a limbus based or fornix based conjunctival flap.
- Dissect the episcleral and Tenon's membranes to expose bare sclera. Blood vessels are carefully cauterized.
- If needed, antimetabolite (cytotoxics) can be used (i.e. Mitomycin-C at a concentration of 0.4mg per ml or as per the surgeon's request). To use this, place the antimetabolite onto a small sponge(s) and place over a wider area of sclera for 2-3minutes. Remove and thoroughly wash away. Note: full precautions and protective equipment are required when using these agents. Please see section 5 for further information regarding the care and handling of antimetabolites.
- Raise a half thickness triangular or rectangular scleral flap, and dissect forward about 1mm into the cornea with a No.15 BP blade. The flap is then folded forwards.
- Make a side-port using a 30G needle - to help decompress the eye and help form the chamber at the end of the procedure.

- Make an entry into the AC with a 3.2 Keratome (or size as per the surgeon's requirements).
- Excise a rectangular block of sclera tissue - including the trabecular meshwork, from the posterior corneal lip (of scleral tissue) overlying the surgical limbus, using a Kelly's punch.
- Hold the peripheral iris tissue with an Iris forceps, and a surgical iridectomy is performed using Vannas scissors - thus allowing free flow of aqueous from the AC to sub-conjunctival space.
- Secure the flap angles with three 10-0 nylon sutures to create a bleb, with one fixed apical and two side sutures.
- Ensure (the nurses) have completed the Sign-Out surgical count, prior to the final wound closure.
- Close the conjunctiva with 8-0 vicryl suture or 10-0. nylon suture, depending on surgeon preference
- Wound is checked prior to removing drape and arranging dressing.

In recent times, a number of alternative measures are used, like Ologen which is a glycosylated collagen matrix. It is a cylindrical structure measuring 6 X 2 mm and is placed after closure of the scleral flap and before conjunctival closure. Some surgeon's may use this technique as they find it highly beneficial in eyes with high myopia, young individuals, and thin sclera, where antimetabolites are contra-indicated.

Post-operatively all patients receive a tapering dose of an antibiotic, steroid and a homide twice daily for one week (or as per surgeon preference). All anti-glaucoma medications are stopped after Trabeculectomy and patients are reviewed at 2 weeks, 4 weeks and 8 weeks, with close monitoring of their IOP. By digital massage, loose sutures are also removed and/or bleb needling occurs until an adequate IOP control is achieved.

Duration of procedure: 35 minutes (plus additional time if valves are used).

Valves

While not universal – possibly due to resource limitations, a valve system can be used to assist patients who do not benefit from a traditional Trabeculectomy. The valve is a manufactured device which contains a drainage tube and a one-way valve system. It is implanted into the eye to allow the fluid to drain-out (but not to allow anything else to go into the eye). It is sutured into place. There are a variety of devices available, both for children and adults.

Nursing considerations

- Depending on the procedure and access to resources, the valve can be surgically covered over with a small scleral tissue patch or manufactured patch.
- The valve, manufactured patch and/or scleral tissue patch, needs to be checked during Sign-Out and Time-Out, and documented/logged as an implant in nursing and surgeon notes. Additional care of the scleral tissue is also needed – please see section 5 regarding care of human tissue for ocular application (transplantation).

Complications at time of surgery

Bleeding

- This can be avoided by cauterisation of the conjunctiva and along the edges of the flap before it is incised.

'Button-holing' of the scleral flap

While carefully dissecting the scleral flap, it is necessary to ensure a uniform thickness of the flap (bleb) is maintained. If the flap becomes too shallow, a hole can develop in the flap. This threatens the integrity of the flap post-operatively.

Management

- The hole in the flap should be sutured with a 10/0 Nylon. After the operation the surgeon must reform the AC. This will gauge the effectiveness of the flap on the first day after surgery. If the hole in the flap is not secure and there is excess leakage of the aqueous, the operation site should be closed and another site identified. Alternatively, a scleral or corneal patch graft is used to cover the hole in the flap and sutured to the adjacent sclera bed with 10/0 nylon.

Flat or shallow anterior chamber

In this instance, the aqueous drains too freely out of the AC.

Causes

- The flap is allowing too much fluid out because the Trabeculotomy fistula has not been sealed effectively. This is particularly common after the use of an antimetabolite such as 5FU or MMC.
- Loose suturing. The placement of the suture on the flap needs to be secure but not too tight. If too loose, excess drainage of aqueous will occur.

Antimetabolites/cytotoxic agents common in eye care include:
Fluorouracil (5FU) and Mitomycin C (MMC)

The use of antimetabolites/cytotoxics in glaucoma surgery, helps prevent post-operative scarring caused by bleb fibrosis. Application of multiple, small swabs, soaked in antimetabolite, to the sub-tenon's space, has achieved major advances in preventing fibrosis. In addition, sub-conjunctival injections are sometimes required post-operatively. The success of glaucoma filtration surgery depends on good, filtration bleb formation, without scarring. There is little margin for error when using antimetabolites as severe complications can occur, though many are reversible. Long-term cumulative effects can occur in patients receiving antimetabolites and also in medical staff handling them. Careful preparation and disposal of these agents are vital. Training is required in safe and proper use. Please see section 5 for further information.

Diabetic Eye Disease

The Aravind Hospital Team

Diabetic retinopathy is the most common diabetic eye disease and a leading cause of blindness. It is caused by changes in the blood vessels of the retina. In some people with diabetic retinopathy, blood vessels swell and leak fluid. In other people, abnormal new blood vessels grow on the surface of the retina. The retina is the light-sensitive tissue at the back of the eye. A healthy retina is necessary for good vision.

Diabetic retinopathy has four stages:

1. **Mild nonproliferative retinopathy** - At this earliest stage, micro aneurysms occur. They are small areas of balloon-like swelling in the retina's tiny blood vessels.
2. **Moderate nonproliferative retinopathy** - As the disease progresses, some blood vessels that nourish the retina are blocked.
3. **Severe nonproliferative retinopathy** - Many more blood vessels are blocked, depriving several areas of the retina of their blood supply. These areas of the retina send signals to the body to grow new blood vessels for nourishment.
4. **Proliferative retinopathy** - At this advanced stage, the signals sent by the retina for nourishment trigger the growth of new blood vessels. This condition is called proliferative retinopathy. These new blood vessels are abnormal and fragile. They grow along the retina and along the surface of the clear vitreous. By themselves, these blood vessels do not cause symptoms or vision loss, however, they can also have thin and fragile walls. If they leak blood, severe vision loss and even blindness can result.

Often there are no symptoms in the early stages of the disease, nor any pain. It is essential that patients are encouraged to lead a healthy life and have regular eye examinations rather than waiting for symptoms to appear. It is recommended that they have a comprehensive, dilated eye exam at least once a year. Blurred vision may occur when the macula—the part of the retina that provides sharp central vision—swells from leaking fluid. This condition is called macular oedema. If new blood vessels grow on the surface of the retina, they can bleed into the eye and block vision.

Diabetic retinopathy and macular oedema are detected during a comprehensive eye exam that includes:

- **Visual acuity test** - This eye chart test measures vision and different distances.
- **Dilated eye exam** - Drops are placed in the eyes to widen or dilate the pupil. This allows the eye care professional to see more of the inside of the eyes and check for signs of disease. A special magnifying lens is used for examination of the retina and optic nerve, i.e. looking for signs of damage and other eye problems. After the exam, close-up vision may remain blurred for several hours due to the eye drops/dilated pupil.
- **Tonometry** - An instrument measures the pressure inside the eye. Numbing drops may be applied to the eye for this test.

No treatment is needed during the first three stages of diabetic retinopathy, unless the person has macular oedema. To prevent progression of diabetic retinopathy, people with diabetes should control their levels of blood sugar (glucose), blood pressure, and blood cholesterol.

Proliferative retinopathy is treated with laser. This procedure is called scatter laser treatment or pan-retinal photocoagulation or PRP. Scatter laser treatment helps to shrink the abnormal blood vessels and also acts to direct blood supply to the important central portion of the retina. Intra-vitreous anti-VEGF injections are also now used to address proliferative DM retinopathy. These agents can cause the regression of the abnormal blood vessels. If the bleeding is severe, the person may need a surgical procedure called a vitrectomy.

Vitreoretinal Surgery (Vitrectomy)

Hunter Cherwek

Name of eye disease: Multiple. This is because retinal issues can occur for several reasons, such as:

- retinal detachment
- diabetic eye disease (especially tractional retinal detachment and non-clearing vitreous hemorrhage)
- intraocular foreign body/trauma
- dropped crystalline lens or dropped IOL
- macular surgery (macular hole, macular pucker or epiretinal membrane).

Surgical technique/definition

Surgical intervention happens when the eye experiences structural changes or pathologic events to the posterior segment which compromise the patient's vision. It is especially important to know about retinal detachments (i.e. the retina has separated from the choroid which supplies much of the retina's oxygen & nutrition). When evaluating the patient with a retinal detachment, it is important to determine the location of any breaks/tears in the retina, the lens status of the eye (IOL vs crystalline lens), and if the macula is involved (so called "macular-on" or "macular-off").

A vitrectomy procedure basically involves the removal and replacement of the vitreous with, for example, balanced salt solution (BSS), intraocular gas (which is slowly absorbed), or silicone oil (which has to be removed by a later surgery). The surgeon removes the vitreous (which is like a clear jelly unless the patient has bled into the vitreous) to release either traction on the retina caused by problems within the vitreous, or to prevent the surgical instruments from causing traction during surgery (which may lead to a retinal detachment).

A vitrectomy is done when three small incisions are made along the sclera corresponding to the overlying area between the iris and retina – the region known as the Pars Plana. Through these three incisions, the surgeon can control what is happening inside the eye. These ports are:

1. **Infusion port** - which is attached to a BSS bottle either by gravity or machine-pump. This is how the BSS enters the eye when the vitreous is removed. The surgeon can use this port to control the IOP and introduce agents such as filtered air, should they need too.
2. **Light pipe** – to illuminate the area.
3. **Instrument entry hole** - that the surgeon can use to introduce instruments and agents needed to repair the cornea. The vitreous cutter, which functions as a high speed guillotine that operates at many cuts per minute (CPM), is also placed through this port. The cutter can remove the vitreous gel while exerting minimal traction on the attached retina.

Once the vitrectomy part has been completed, the surgeon can start the surgical repair. It depends on what is wrong with the individual patient as to what other procedures are needed, but in general, there are several surgical procedural steps that can occur. These include:

Outside the eye

- **Scleral buckling for retinal detachment** – where silicone tubes and silicone pieces are secured around the outside. This helps to put pressure on the internal apparatus and prevent further damage.
- **Cryotherapy** - to re-attach the retina to the blood supply

(choroid) and stop the tear from extending.

- **Paracentesis** – a small 'cut' in the sclera to release any fluid built-up behind the retina. The surgeon slowly teases the fluid out.

Inside the eye

- pars plana vitrectomy for either rhegmatogenous or tractional retinal detachment
- macular hole surgery
- epiretinal membrane peeling
- core vitrectomy for endophthalmitis or non-clearing vitreous hemorrhage
- dropped IOL or crystalline lens (common posterior segment complications from complicated cataract surgery)
- intravitreal injections including anti-VEGF or corticosteroid.

Pre-operative preparation

- dilate the pupil.

Special patient education tips for patients awaiting this surgery

- Pre-operative care includes dilating drops along with the recommended antibiotics and possible topical anesthesia. Furthermore, patients with diabetes and hypertension should be closely monitored with anesthesia in the pre-operative period.
- This surgery can take a lot longer than other intraocular procedures so careful selection of anaesthetics is needed.
- During surgery, it is important for the patient to be instructed to lie still and to report any discomfort.
- Post-operative care includes pain control, monitoring of blood sugar and blood pressure, and any possible post-operative nausea.
- Special post-operative education depends on the type of retinal procedure but with cases in which an intraocular gas bubble is placed inside the eye, it is critical that the entire surgical team emphasise the importance of head positioning (including possible face down positioning which is common in macular surgery) and not to fly until cleared by the surgeon.
 - flight education is important as the gas bubble can expand while in higher altitude/hypobaric environments
 - education about the signs of retinal detachment, including new onset of floaters, flashing lights, and/or a "shade" or "curtain" coming over their vision, is also important
 - finally, educating the patient on the need to declare the presence of the bubble to other healthcare providers is essential. This is to prevent issues with anaesthetics in the future – while the bubble remains.
- Sometimes, surgeons may require patients to be administered with IV or oral Diamox (acetazolamide) - used to reduce the pressure in the eye. Always check to see if this has been requested as it may or may not always be routine. Make sure allergies are checked before administering this medication - and notify the surgeon if allergies are known.

Setting up for retinal surgery (common):

Note: it is critical for the entire surgical team to read the operator's manual for all surgical equipment.

Instruments

- forceps
- scissors
- pick
- extrusion
- tano scraper
- fragmatome
- scleral depressor.

Machines and their accessories

- vitrectomy machine and accessory packs/tubing
- cryo machine – and probe. With correct gas evacuation tubing in place
- vitrectomy machine with specific gauge size 20, 23, 25, and 27 (23, or smaller, gauge surgery is often performed without sutured ports)
- laser (either endolaser or Laser Indirect Ophthalmoscopy) – ensure full laser safety precautions are in place.
- operating microscope with foot pedal control with surgeon's viewing system which may require an image inverter:
 - any viewing devices - either re-usable or disposable may be attached to the microscope. Re-usable devices are sterilized and changed between patients.
- indirect ophthalmoscope designated for the OT
- bipolar diathermy and tips for both external and internal use
- optional:
 - wrist-rest. This is a metal bar that sits close to the patient's head. When covered in a drape it provides both a wrist-rest for the surgeon and a sterile pocket to catch fluid or instruments during the procedure
 - arm chair rest. Some surgeons may request to lean on their arms, so, a surgical chair with arms is required (if available). The scrub nurse will need to cover the arms with sterile covers to help maintain the sterile field.

Medications

- intra-ocular irrigating solutions to replace the vitreous
- topical, subconjunctival or intravitreal antibiotics and steroids
- Indocyanine Green (ICG) dye for staining the membrane prior to peel
- silicone oil
- heavy liquid
- intraocular gas (filtered air, C3F8 or SF6) – it is critical that the surgical team know the proper percentage of these injected gases and proceed with the treatment under sterile conditions.

Consumables for scleral buckle

- sutures and muscle manipulation suture material
- scleral buckle components
- muscle hooks to help loop the manipulation sutures through the muscles
- indenter.

Scrub nurse duties

- Participation in SSS checking system.
- Proper surgical prepping, draping and sterile technique throughout case.
- Set-up of all potentially required machines including cryo machine, vitrectomy machine, and lasers.

- Pre-check/tests completed.
- Hand instruments and anticipate surgical/surgeon needs. Please see section 5 regarding instrument handling techniques.
- Adjust the vitrectomy machine parameters during surgery.
- Assist with surgical visualisation including possible usage of the inverter, viewing lens mobilisation, and applying requested coating materials to the cornea surface.
- Monitor BSS level (depending on the machine).

Note

- Retinal surgery often requires a dark room to help illuminate the inside of the eye. Nurses must be familiar with the procedure and take safety steps to ensure they are safe and comfortable working in a darkened environment.
- Be careful not to knock the surgeon or bump the patient's trolley as this movement can be magnified inside the eye.
- If lasers (even endolasers) are used during retinal surgery, it is important for all staff in the OT to wear the designated protective eye wear to prevent potential eye injuries amongst operating room staff. Please see section 6 regarding safe Laser use.

Oculoplastics

John Cooper and the Aravind Hospital Team

There are many reasons why patients might require oculoplastic surgery – and there are a wide variety of techniques that surgeons use. This section will only outline general conditions and it is to be used as a guide only. Always consult the surgeon for their preferred method/techniques/needs.

Preparing oculoplastic patients

- No dilation or constriction of this pupil is needed. This group of patients requires surgery to the skin, tissue, muscle and occasionally bone around the eye.
- Bleeding is the biggest risk to this group of patients, both during the procedure and post-operatively;
 - depending on the surgeon/hospital policy, the pre-operative nurses may be required to find out if a patient is taking blood-thinning medication a few days (or a week) prior to admission. This is to prevent excess bleeding. If unsure, talk with the surgeon and find out if they would/would not like the pre-operative nurses to check this. Standing orders may include potentially asking the patient to withhold a dose or two.
- Additionally, some hospitals may ask the patient to identify any metal inside or on their body as many of the larger procedures may use a cautery/diathermy machine for monopolar cutting and coagulation. Some of these machines can heat-up parts of the body, where there is metal, when not positioned correctly. This can result in burns to the patient. Please see section 6 – Electrosurgery - for information on how to work with the cautery/diathermy machines.

Enucleation

This is the removal of the intact globe by cutting the optic nerve and extraocular muscles. This can be performed for malignant tumours.

Indications

- intraocular tumours - especially malignant tumours
- painful blind eye
- end stage glaucoma
- trauma - severe globe injury
- cosmetic reasons.

The surgery

- Complete the SSS check and protect the non-operative eye
- administer local anaesthetics with/without sedation, though sometimes it may be best to have the patient under general anaesthesia. Please see section 4b for further information on anaesthetics' types
- complete a 360 degree peritomy around the limbus (where the sclera becomes cornea) to lift the conjunctiva from the sclera
- isolate and individually remove the extra-ocular muscles
- sever the optic nerve using scissors
- stop any bleeding
- insert an orbital implant (if applicable)
- closure of the tenon's/conjunctival layers.
- dressing of wound.

Duration of the procedure: 20-30 minutes

Equipment

- non-toothed forceps (conjunctiva)
- toothed forceps/Westcott scissors
- squint hook
- curved enucleation scissors
- diathermy/swabs
- sutures to close conjunctiva
- dressing (may apply mild to moderate pressure).

Complications

- Intra-operative: bleeding and ocular cardiac reflex (causing asystole/severe bradycardia) especially associated with cutting/manipulating extra-ocular muscles.
- Post-operative:
 - pain and discomfort
 - swelling
 - conjunctival chemosis
 - nausea/vomiting
 - infection.

Management

- Infection - consider topical/systemic oral antibiotics.
- Bleeding - can be controlled with a swab and firm pressure for 5 minutes or diathermy if available.
- Long-term and orbital prosthetic may be an option for cosmesis.
- Padding: i.e. pressure dressing. This is a surgeon's preference. Some will not pad while others will apply a firm pad for 24hrs. Please check with the surgeon.

Nursing considerations

- Provide analgesia if ordered for pain.
- Monitor for bleeding, pain and swelling – if padded - alert the surgeon to excess pain and swelling in case they need to

remove the pad and examine prior to discharge.

- Use aseptic techniques, hand-hygiene and clean gloves at all times.
- Provide patient education, especially cleanliness, monitoring for bleeding/swelling under the skin and how to administer any topical antibiotics.
- Provide considered psychological support.

Evisceration

This is the removal of the globe content, leaving the sclera and optic nerve intact. This procedure is performed in the event of endophthalmitis or a painful blind eye.

Indications

- painful blind eye
- end stage glaucoma and trauma
- endophthalmitis
- trauma - severe globe injury
- cosmetic reasons.

Contraindications

- Intra-ocular tumour, due to the risk of the tumour spreading through the sclera and eventually leading to recurrence.

The surgery

- Complete the SSS check and protect the non-operative eye
- administer local anaesthetics with/without sedation
- complete a 360 degree peritomy around the limbus (where the sclera becomes cornea) to remove cornea
- excise the cornea
- scoop out and curette the intra-ocular contents: crystalline lens, uveal body and choroid, vitreous and retina
- stop any bleeding
- the intra-ocular sclera should be cleaned using alcohol.
- Insert an orbital implant (if applicable)
- close of the anterior sclera, Tenon's/conjunctival layers
- apply a dressing (may apply mild pressure).

Duration of the procedure: 20 minutes

Equipment

- non- toothed forceps (conjunctiva)
- toothed forceps/Westcott scissors
- evisceration scoop
- alcohol to clean sclera
- diathermy/swabs
- sutures to close sclera and conjunctiva.

Complications

- intra-operatively, bleeding is the biggest risk
- post-operatively:
 - pain and discomfort
 - swelling, conjunctival chemosis
 - nausea/vomiting and infection.

Management

- Infection. Consider topical/systemic oral antibiotics.
 - the patient should be given a course of oral antibiotics

before and after surgery

- if the eye has been eviscerated for endophthalmitis due to trauma, there is a risk of infection after surgery
- bleeding can be controlled with a swab and firm pressure for 5 minutes or diathermy if available.
- Long-term, an orbital prosthetic may be an option for cosmesis.

Nursing considerations

- provide analgesia, if ordered, for pain
- monitor for bleeding, pain and swelling – if padded, alert the surgeon to excess pain and swelling in case they need to remove the pad and examine prior to discharge
- use aseptic techniques, hand-hygiene and clean gloves at all times
- provide patient education, especially cleanliness, monitoring for bleeding/swelling under the skin and how to administer any topical antibiotics
- provide considered psychological support.

Dacryocystorhinostomy (DCR)

This is a procedure to create a new epithelium lined passage-way for tears to flow into the nasal cavity, via the lacrimal sac, when the nasolacrimal duct does not function. This can be performed endoscopically in some circumstances.

Indications

- acquired nasolacrimal duct obstruction
- watering due to primary acquired nasolacrimal duct obstruction
- prevention of infection due to lacrimal duct obstruction before intraocular surgeries
- mucocele of lacrimal sac
- chronic dacryocystitis
- discharge and conjunctivitis in older patients due to lacrimal sac obstruction
- incomplete obstruction with significant impairment of tear flow causing annoying epiphora
- congenital nasolacrimal duct obstruction that cannot be cured by probing.

Pre-operative assessment

- complete history regarding watering
- past history of trauma, previous surgery
- any history of nasal or sinus disease
- any history of systemic illness like hypertension, diabetes, cardiac disease, asthma or bleeding disorder
- medication history - including anticoagulants
- complete ocular examination including syringing and diagnostic probing
- imaging of the obstruction
- blood investigations include complete blood count, haemoglobin, bleeding time and clotting time, HIV
- if needed, physician and ENT referral.

Pre-operative preparation

Lacrimal function will need to be tested. A differential diagnosis of complete nasolacrimal obstruction will need to be concluded via direct syringing, such as a negative sac-washout procedure is one whereby all the fluid is regurgitated. This process requires a syringe filled with saline that is injected, using a blunt-tipped lacrimal cannula - via the upper and lower eyelid punctae.

Anaesthesia

While anaesthesia will be discussed in section 4b, it is important to note that this particular procedure may require a more complex level of anaesthesia, such as:

- general anaesthesia (optional)
- intravenous sedation
- regional anaesthesia
 - subcutaneous injection in surgical site
 - infratrochlear nerve injection
 - peri-infratrochlear nerve injection
 - topical proparacaine drops to eye
 - topical nasal xylocaine spray/jelly to nose.

Surgical technique

- Nasal packing for decongestion.
- A straight vertical incision is made 10 mm medial to the inner canthus, avoiding the angular vein using a No 15 surgical blade.
- The anterior lacrimal crest is exposed by blunt dissection and the superficial portion of the medial palpebral ligament is identified and divided.
- The periosteum is divided from the spine on the anterior lacrimal crest to the fundus of the sac and reflected forwards using Freer's periosteal elevator.
- The suture line between thick maxilla and thin lacrimal bone is identified. A Freer's elevator is used to gently break the suture line and bone behind it a small bone drill may be used in thick bone).
- The anterior lacrimal crest and the bone from the lacrimal fossa are removed using Kerrison's bone nibbling rongeurs (punch).
- A probe is introduced into the lacrimal sac through the lower canaliculus and the sac is incised in an 'H-shaped' manner to create anterior and posterior sac flaps.
- Similar incision is made in the nasal mucosa to create anterior and posterior nasal flaps.
- Silicone intubation may be performed in selected cases like failed DCR, paediatric DCR, common canalicular obstruction and post traumatic cases.
- The anterior flaps are sutured using 6-0 vicryl, posterior flaps are resected out. Flaps can be tented up by suturing to periosteum/muscle (anchoring suture).
- Skin incision is closed with interrupted sutures (6-0 Vicryl or Silk or Prolene).
- Nasal packing may be used to minimise nasal bleeding.

Duration of the procedure: 20-40 minutes

Equipment

- No 15 Blade and handle
- packing materials
- toothed forceps/Westcott scissors
- periosteal elevator
- bone punch (laminectomy/Kerrison/Rongeurs)
- diathermy/swabs
- sutures to close flaps (5/0 Vicryl) and cutaneous closure
- gauze and cotton tips.

Complications

- intra-operative: bleeding
- post-operative:
 - pain and discomfort
 - swelling
 - un-successful surgery
 - wound infection
 - bleeding.

Management

- Infection - consider topical antibiotic ointment on the external wound:
 - oral antibiotics and analgesics for 1 week
 - topical antibiotics in eye and over the wound.
- Bleeding can be controlled with a swab/cotton-bud and firm pressure for 5 minutes or diathermy if available. Nasal Packing may also be used.
- Intubation tubes can be removed after 3-6 months.

Nursing considerations

- provide analgesia if ordered for pain
- monitor for bleeding, pain and swelling. If padded, alert the surgeon to excess pain and swelling, in case they need to remove the pad and examine prior to discharge
- use aseptic techniques, hand-hygiene and clean gloves at all times
- provide patient education, especially cleanliness, monitoring for bleeding/swelling under the skin and how to administer any topical antibiotics
- provide considered psychological support
- discourage the patient from blowing their nose in the first weeks post-op
- discourage the patient from drinking very hot fluids
- If a nasal pack and silicone stents are inserted, then notification of a removal time is required
 - education on how the pack is removed may also be needed.

Dacryocystectomy (DCT)

This is a simpler, and minor lacrimal sac surgery in which the entire lacrimal sac is excised along with the nasolacrimal duct.

Indications

- old and debilitated patients
- systemic contraindications for DCR
- lacrimal sac tuberculosis/sarcoidosis
- lacrimal sac malignancies
- rhinosporidiosis of the lacrimal sac
- infection and sequelae of infection.

Entropion

Entropion is the inward turning of eyelid margin against the globe. The eyelid margin and eyelashes rub against the cornea and conjunctiva causing irritation.

Indications

- foreign body sensation and epiphora
- inverted lower eyelid.

It is important to determine the cause and type of entropion, as they require different surgical considerations, i.e. involuntional – FB sensation, epiphora, inverted eyelid, lid laxity or cicatricial – some loss of fornices, or symblepharon.

Pre-operative preparation

Dependent upon the situation, as there are several approaches.

Surgical technique (this will vary depending on the cause of the entropion and co-morbidities):

- reinsertion of the lower eyelid retractor (IRR)
- Complete the SSS check and protect eye(s)
- Administer local anaesthetic
- make a sub-ciliary incision
- identify lower eyelid retractors and dissect off the conjunctiva
- advance the lower eyelid retractors onto tarsus
- undertake a lateral tarsal tightening procedure if there is also laxity
- consider a full-thickness skin graft to correct any reduction of skin
- close the skin.

Equipment

- toothed forceps and Westcott scissors
- No 15 Blade and handle
- diathermy
- suture forceps
- traction suture

Other conditions/techniques

- Congenital entropion (HOTZ procedure) - is performed by excising a fold of skin and orbicularis medially in the lower lid margin with tarsal fixation.
- Retractor reinsertion procedure (Jones procedure) –The goal of this procedure is to correct laxity of lower lid. Lateral tarsal strip can be combined to overcome horizontal lid laxity. A sub-ciliary skin incision is made, the lower lids are retracted and separated from fat anteriorly and conjunctiva posteriorly. The tarsus is then attached.
- Lateral Tarsal Strip (LTS) – This is usually combined with retractor reinsertion surgery. Lateral canthotomy and inferior cantholysis. A strip of tarsus is prepared and sutured to periosteum using 4-0 Prolene.
- Weis procedure – Performed if preseptal overriding is predominant.
- Quickert procedure – Performed if preseptal overriding is associated with horizontal lid laxity.
- Tarsal fracture operation - Performed for lower lid cicatricial entropion.
- Anterior lamellar reposition – Performed for mild upper lid entropion. It can be combined with tarsal wedge resection in moderate cases of upper lid entropion.

Duration of the procedure: 30 minutes

Complications

- bleeding – pressure/diathermy
- under/over correction
- swelling and bruising
- infection.

Management

- Infection - consider topical antibiotic ointment on the external wound.
- Bleeding - can be controlled with a swab/cotton-bud and firm pressure for 5 minutes or diathermy if available.

Nursing considerations

- provide analgesia if ordered for pain
- monitor for bleeding, pain and swelling. If padded, alert the surgeon to excess pain and swelling, in case they need to remove the pad and examine prior to discharge
- use aseptic techniques, hand-hygiene and clean gloves at all times
- provide patient education, especially cleanliness, monitoring for bleeding/swelling under the skin and how to administer any topical antibiotics
- provide considered psychological support.

Ectropion

Ectropion is the outward turning of the eyelid margin away from the globe. Patients may complain of irritation, watering and redness of lid margin.

Indications

Upon examination, the eyelid is either obviously turned out away from the eye and/or can be physically pulled away (lid distraction) with ease over >6mm. Surgery is indicated in ectropion, but conservative option may be to consider lubricants and steroids to control cicatricial element.

A wedge procedure may be performed (as mentioned for entropion) or a more complex eyelid tightening procedure to shorten the eyelid and elevate slightly at lateral canthus.

Surgical technique

1. Complete the SSS check and protect eye(s)
2. administer local anaesthetics
3. perform a lateral canthotomy (down to orbital rim/periosteum)
4. perform a cantholysis (cutting the lower limb of the lateral canthal tendon off the orbital rim)
5. split the posterior and anterior aspects of the released lateral eyelid
6. shorten the strip, being conservative
7. reattach the strip to the inner aspect of the orbital rim periosteum. Assess position
8. remove redundant anterior lamella
9. close wound.

Other conditions/techniques

- Pentagon wedge resection – Performed for lower lid ectropion with horizontal lid laxity. A full thickness wedge at lateral 1/3rd and medial 2/3rd is made and sutured in three layers.
- Kuhnt – szymanski procedure – It is a combination of pentagon wedge resection with lower lid blepharoplasty.
- Lateral Tarsal Strip (LTS) procedure – This is performed for mild to moderate lower lid ectropion with generalised horizontal lid laxity. A lateral canthotomy and inferior cantholysis is performed. A strip of tarsus is prepared and sutured to periosteum using 4-0 Prolene.
- Medial conjunctivoplasty – It is done for punctal eversion. A diamond shaped incision is made below lower punctum and

sutured (suture and scar in lower lid retractors acting as the inverting force).

- Medial Canthal Tendon (MCT) - plication – Is performed if medial canthal laxity is predominant.
- Cicatricial ectropion – If a small scar is present, a Z-plasty/ V-Y can be done. Larger scars with severe ectropion may need scar resection and full thickness skin grafting.
- Paralytic ectropion – Lateral tarsorrhaphy and/or medial canthoplasty can be performed. In mild cases lid taping at night and lubricants are important.

Duration of the procedure: 30 minutes

Equipment

- Westcott scissors
- toothed forceps
- suture
- suture tying forceps
- diathermy.

Complications

- bleeding from the periosteum – apply pressure and/or diathermy.

Management

- Infection - consider topical antibiotic ointment on the external wound
- Bleeding - can be controlled with a swab/cotton-bud and firm pressure for 5 minutes or diathermy if available.

Nursing considerations

- provide analgesia, if ordered, for pain
- monitor for bleeding, pain and swelling – if padded, alert the surgeon to excess pain and swelling in case they need to remove the pad and examine prior to discharge
- use aseptic techniques, hand-hygiene and clean gloves at all times
- provide patient education, especially cleanliness, monitoring for bleeding/swelling under the skin and how to administer any topical antibiotics
- provide considered psychological support
- patient to avoid rubbing the eyelid.

Ptosis repair (acquired)

This is the abnormal lowering of the upper eyelid and can be caused by several factors, i.e. involutional – age related disinsertion of the levator muscle due to a variety of reasons including trauma, contact lens wearing, post-surgery, Neurogenical – third nerve palsy/ horners syndrome, or mechanical – oedema, or myasthenic.

Indications

Ptosis is a complex problem and may be associated with other aetiologies such as dermatochalasis (excess folds of eyelid skin) and brow ptosis (droopy brow). Careful examination, assessment and history are required to discern the type of ptosis. Assessment of levator function, lid movement, lagophthalmos, upper eyelid skin crease and bells phenomenon will be required. Visual obstruction and cosmesis are the common indications for surgery.

The most common procedure is the levator aponeurosis advancement, and the potential risks/outcomes should be discussed with the patient.

Surgical technique

1. Complete the SSS check and protect eye(s)
2. administer local anaesthetics
3. insert a lid traction suture
4. upper eyelid skin crease incision
5. identify and dissect levator muscle aponeurosis
6. advance levator to the appropriate level, this will need to be assessed at the time of surgery by sitting the patient up
7. close the skin and reform of skin crease.

Other modes of treatment and technique

- refraction and amblyopia treatment especially in children
- crutch glasses can be given temporarily in adult patients
- fasanella servat surgery – can be performed for mild ptosis with good levator action
- levator resection – performed for a mild to moderate ptosis with fair to good levator function. Skin crease incision is given. LPS is identified and dissected from conjunctiva below and fat above. It is then sutured to anterior surface of tarsus
- frontalis sling surgery – Performed for ptosis with poor LPS action, usually using a silicone material (silicon rod) as a sling.

Duration of procedure: 40 minutes

Equipment

- traction suture (silk)
- toothed forceps
- Westcott scissors
- diathermy
- suture holder and 5/0 Vicryl
- skin sutures.

Complications

- peri-operative bleeding (manage with diathermy)
- under or overcorrection of ptosis
- exposure keratopathy
- suture abscess or granuloma.

Management

- Infection - consider topical antibiotic ointment on the external wound
- Bleeding - can be controlled with a swab/cotton-bud and firm pressure for 5 minutes or diathermy if available.

Nursing care considerations

- provide analgesia, if ordered, for pain
- monitor for bleeding, pain and swelling. If padded, alert the surgeon to excess pain and swelling, in case they need to remove the pad and examine prior to discharge
- use aseptic techniques, hand-hygiene and clean gloves at all times
- provide patient education, especially cleanliness, monitoring for bleeding/swelling under the skin and how to administer any topical antibiotics
- provide considered psychological support
- lubricants for the foreseeable future, 24hours/day.

Incision and curettage of chalazion

A chalazion is a chronic, sterile, granulomatous inflammatory lesion caused by retained secretion leaking from Meibomian glands. Draining the glands is the only way to provide relief from this condition.

Causes and risk factors

- blepharitis
- dry eyes
- dry/dirty work conditions
- make-up.

Surgical technique

This procedure is considered a minor-procedure.

- Complete SSS check and protect eye
- administer local anaesthetic
- apply chalazion clamp over lesion
- evert eyelid using clamp
- use a No 11 Blade to incise the lesion vertically
- curette the contents of the chalazion and excise the fibrotic sac
- remove clamp
- pad for 2 hours post-op.

Duration of the procedure: 10 minutes

Equipment

- chalazion clamp
- No 11 blade and handle
- curettes of various sizes
- pad/lanolin dressing
- 0.2 toothed forceps and Westcott scissors for the sac.

Complications

- scarring
- bruising
- swelling
- recurrence of the problem.

Nursing considerations

- provide analgesia, if ordered, for pain
- monitor for bleeding, pain and swelling. If padded, alert the surgeon to excess pain and swelling, in case they need to remove the pad and examine prior to discharge
- use aseptic techniques, hand-hygiene and clean gloves at all times
- provide patient education, especially cleanliness, monitoring for bleeding/swelling under the skin and how to administer any topical antibiotics
- provide considered psychological support
- educate patient on the need for good hygiene – especially with regard to removal of make-up from around the eyes.

Excision of eyelid lesion(s) malignant and non-malignant

Applicable for lesions such as:

- sebaceous cyst
- seborrhoeic keratosis
- xanthelasma
- epidermal inclusion cyst
- actinic keratosis
- meibomian gland cyst
- tarsal cyst
- cyst of Moll
- cyst of Zeis
- retention cyst
- small dermoid and dermolipomas
- benign and malignant masses
 - papilloma
 - small neurofibromas
 - warts
 - chronic granulomas
 - basal cell carcinoma
 - squamous cell carcinoma
 - meibomian gland carcinoma.

Equipment

- Westcott scissors/non-toothed forceps
- No 15 Blade and handles
- swabs
- marking pen
- diathermy.

Treatment/surgery

Most of the cystic lesions or lid masses are excised (i.e. shave excision or total excision with suturing) and sent for histopathological evaluation.

Nursing considerations

- Diathermy - most of these lesions are likely to bleed a lot during surgical removal.
- Education - patients will need to be prepared to understand the nature of the problem
 - psychological preparation - is important and referral to the surgeon to answer their questions is essential.
- Post-operative pain management will also have to be managed.

Lid abscess

These usually present as painful, inflamed, localised, fluctuant swelling with or without a pus point.

Management/surgical technique

- incision and drainage of the pus using an No 11 blade for stab incision - internal loculi are broken
- pus is expressed and sent for culture
- an appropriate antibiotic is prescribed.

Complications

- bleeding and recurrence of abscess.

Orbital exenteration

This is the complete removal of the orbital content including the eye, extra-orbital muscles, fat, lacrimal apparatus, eyelids and bone. This facially disfiguring procedure has a profound, psychological impact and may take many months to heal.

Indications

- significant malignant tumour and life threatening conditions.

Pre-operative Preparation

Patient preparation will be important. Explanations of the reasons for surgery and the long term effects have to be explained thoroughly.

Surgical techniques

- Complete the SSS check, and protect the non-operative eye
- Administer local anaesthetic and sedation
- if possible mark the extent of the excision
- use a No 15 blade to make initial incision and use scissors to release tissue
- Use a periosteal elevator to lift the periosteum from the orbital bones
- clamp optic nerve prior to cutting
- cut orbital nerve and remove orbital contents
- stop any haemorrhage
- apply dressings.

Duration of the procedure: 30-40 minutes

Equipment

- heavy non-toothed forceps/Mackindo scissors
- diathermy and swabs
- periosteal elevator (Freer)
- dressings.

Complications

- heavy bleeding that will require control.

Management

- Infection - consider topical antibiotic ointment on the external wound.
- Bleeding - can be controlled with a swab/cotton-bud and firm pressure for 5 minutes or diathermy if available.

Nursing considerations

- provide analgesia, if ordered, for pain
- monitor for bleeding, pain and swelling. If padded, alert the surgeon to excess pain and swelling, noted in case they need to remove the pad and examine prior to discharge
- use aseptic techniques, hand-hygiene and clean gloves at all times
- provide patient education, especially cleanliness, monitoring for bleeding/swelling under the skin and how to administer any topical antibiotics
- provide considered psychological support
- ongoing dressing changes as required in the following weeks.

Paediatric Ophthalmology

S. Grace Prakalapakorn

This section shall focus on paediatric cataracts, strabismus (squint), retinopathy of prematurity (ROP) (also known as retrolental fibroplasia), and retinoblastoma/malignancy and Examination Under Anaesthetics (EUA).

Paediatric cataract surgery

Name of eye disease: congenital or acquired cataract

Definition: opacity of the normally clear crystalline lens

Anaesthetic type: General Anaesthetic

Pre-operative preparation

- dilate the pupil.

Surgical technique

While the techniques are similar to those utilised for adults, they are adapted to suit children, size and the fragility of their eye. Such procedures may include:

- ECCE + PPC (primary posterior capsulorhexis) + AV
- SICS + PCIOL + PPC + AV
- Membranectomy
- Secondary IOL.

Signs and symptoms

- leukocoria (white pupil)
- decreased red reflex
- poor vision
- strabismus
- nystagmus
- unilateral or bilateral cataract
- partial or complete cataract
- stable or progressive cataract.

Causes

- hereditary or sporadic
- congenital or acquired (trauma, medications, systemic disease)
- isolated or part of a systemic condition.

Management

non-surgical management:

- glasses
- amblyopia therapy (patching or atropine to blur vision in the better seeing eye)
- dilation of pupils (to enable vision around the cataract).

surgical management:

- lensectomy ± intraocular lens implantation ± posterior capsulotomy and anterior vitrectomy, for infants and young children, because posterior capsule opacification occurs rapidly.

Instruments

- wire speculum
- vitreal cutting instrument

- manual irrigating/aspirating device
- viscoelastic material
- MVR blade (20g or 23g) ± 66/69 blade and keratome to make scleral wound
- 8-0/9-0 absorbable suture (vicryl) and 10-0 non-absorbable suture (nylon) (to close wound – surgeon dependent)
- 6-0 Silk traction suture
- miochol or miostat (if placing an intraocular lens)
- ± Intraocular lens (single-piece PMMA or single/3-piece acrylic lens)
- ± Intraocular forceps and scissors (if there is a fibrous plaque).

Complications at time of surgery

- see previous general section on cataract extraction
- specific to children:
 - secondary cataract (opacification of the posterior capsule) is more common and occurs earlier in children
 - inflammation (especially if implanting an intraocular lens)
 - glaucoma
 - post-operative bleeding.

Patient education

- Avoid strenuous activity for 2 weeks after surgery.
- Do not rub the eyes after surgery, keep a hard shield over the eye for 2 weeks – do NOT occlude the vision in the operated eye: use a clear shield or a shield with holes that the child can see through and use tape only on the edges of the shield.
- Return immediately for decrease in vision, yellow/green discharge, extreme pain, and increase in eye redness.

Surgical techniques

- Time-out is completed
- child is anaesthetised
- prepping & draping is completed
- noting corneal diameter and EUA (including B-scan if no view of the posterior segment and A-scan/keratometry for IOL calculations)
- limbal incisions (surgery without IOL implantation)/ scleral/ corneo-scleral tunnel (for surgery with IOL implantation)
- CCC vs vitrectorhexis, +/- hydrodissection, cataract aspiration
- IOL implantation (+/-), PPC (primary posterior capsulorhexis) with anterior vitrectomy
- peripheral iridectomy (+/-), visco wash
- AC formation and section suturing with subconjunctival steroid and antibiotic injection.

Strabismus (squint) surgery

Name of eye disease: strabismus

Definition: Misalignment of the eyes. This may be of one eye or both (unilateral/bilateral). This procedure is mostly performed on children but from time-to-time adults may elect to undergo alignment surgery.

The surgery is conducted to try and align the eyes so that they are straight and moving together. The goal is to realign the eyes and improve binocularity. This is done by the surgical manipulation of the muscles around the eye. Which muscles the surgeon chooses to weaken, strengthen, etc. depends on the severity and type of the misalignment. Therefore, the nursing teams need to be aware

of each patient's needs. This will help the nurse to determine what they need, i.e. how many sutures they will need.

Signs and symptoms

- eyes turn in, out, or one is higher than another
- double vision
- abnormal head position (head tilt, head turn, chin lift, head down posturing).

Causes

- congenital or acquired
- poor vision in one eye due to difference of vision between the two eyes caused by a difference in refractive error between the two eyes, congenital anomalies such as cataract or optic nerve hypoplasia, tumour, etc.
- uncorrected refractive error of both eyes, such as significant hyperopia, which may cause inward turning of the eyes
- neurologic disorder.

Management

- non-surgical management:
 - glasses to correct refractive errors or increase or decrease accommodation in order to improve eye alignment, +/- prisms for temporary treatment (e.g. sixth nerve palsy)
 - amblyopia therapy (patching or atropine to blur vision in the better seeing eye)
- surgical management:
 - strabismus surgery.

Instruments

- lid speculum
- handheld high-temperature cautery
- muscle hooks (Steven's, Jameson, Greene hooks)
- muscle clamp/straight haemostat
- 6-0 Double-armed Vicryl suture on spatulated needle (e.g. S-14, helpful if the suture is dyed)
- 8-0 Vicryl suture (e.g. Ethicon TG140-8)
- Westcott scissors
- needle drivers
- toothed forceps x 2
- tying forceps x 2
- Moody-locking forceps x 2
- sterile cotton tipped applicators
- calipers or a Scott measuring device with millimetre markings
- phenylephrine 2.5 % eye drops.

Complications at time of surgery

- scleral perforation - due to full thickness scleral wound, can lead to vitreous haemorrhage, retinal detachment and endophthalmitis
- subconjunctival haemorrhage
- excessive bleeding.

Complications after surgery

- subconjunctival haemorrhage
- infection
- dellen formation - corneal thinning due to swollen tissue next to the limbus

- conjunctival cyst - occurs if the conjunctival epithelium is buried during wound closure
- Prolapse of tenon's capsule: due to incomplete closure of the conjunctiva
- allergic reaction - due to suture material or eye drops
- suture granuloma
- duction limitation - due to large recessions or a slipped muscle
- eyelid abnormalities - due to incomplete dissection of the vertical muscles from the eyelid attachments and scar formation
- over-correction or under-correction of eye alignment.

Patient education

- post-operatively, it is normal to have blood-tinged tears for a few days
- avoid swimming, getting dirt, sand, or other things in the eye for 2 weeks after surgery
- do not rub the eyes after surgery
- return immediately for decrease in vision, increase in eye redness, yellow/green discharge, and extreme pain.

Retinopathy of Prematurity (ROP)

Name of eye disease: retrolental fibroplasia

Definition: abnormal retinal vascular development and abnormal neovascularisation due to premature birth

Signs and symptoms

- can range from mild (abnormal vessel development) to serious (retinal detachment and blindness).

Causes

- premature birth (low birth weight and gestational age - country-specific cut-offs) and those born prematurely that have been exposed to high doses of supplemental oxygen, have required cardiorespiratory support, or have an unstable clinical course.

Management

- non-surgical management:
 - repeat fundus examination by an ophthalmologist trained in ROP screening every 1-2 weeks (per recommended guidelines)
- surgical management:
 - laser photocoagulation or cryotherapy of the peripheral, avascular retina
 - intravitreal injection of bevacizumab.

Pre-operative preparation

- dilate the pupil.

Instruments

- lid speculum
- lubricating eye drops (e.g. artificial tears)
- topical anesthetic (e.g. tetracaine, proparacaine, etc.)
- laser photocoagulation:
 - indirect laser and safety glasses
 - depressor
 - 28D lens

- cryotherapy - see section on cryotherapy
- intravitreal injection of bevacizumab:
 - bevacizumab
 - 1mL syringe with 30g needle
 - betadine solution
 - sterile cotton tip applicator.

Complications at time of surgery

- haemorrhage (hyphema, subconjunctival or vitreous haemorrhage)
- cataract
- corneal whitening.

Complications after surgery

- haemorrhage (hyphema, subconjunctival or vitreous haemorrhage)
- inflammation
- exudative retinal detachment
- glaucoma
- endophthalmitis (from intravitreal injection)
- long term: increased risk of refractive error (especially myopia) from laser treatment, strabismus
- other side effects from the intravitreal injection are unknown as yet.

Patient education

- Reinforce to parents the importance of TIMELY follow-up with the ophthalmologist, as scheduled (repeat fundus examination by an ophthalmologist trained in ROP screening every 1-2 weeks initially).

Retinoblastoma/malignancy

Name of eye condition: retinoblastoma

Definition: most common malignant ocular tumour of childhood and usually occurs in children <5 y/o. If untreated, this can be life threatening. Therefore, children who present with this condition need to be seen by an ophthalmologist urgently. As this can be passed on through family members, brothers and sisters should also be examined and genetic counselling should be undertaken for the parents.

Signs and symptoms

- most common: leukocoria (white pupil)
- other presentations: strabismus, vitreous haemorrhage, hyphema (blood in the anterior chamber), ocular or periocular inflammation, glaucoma, proptosis, and hypopyon (white blood cells in the anterior chamber).

Causes

- hereditary (passed on through family) or sporadically. All siblings should be examined.

Diagnosis

- in depth examination: usually requires an EUA procedure
- a Medical Resonance Image (MRI) of the head and orbit, and a ultrasound:
 - note: avoid radiation from Computed Tomography (CT) Scan due to risk of secondary tumours
- in unusual cases, aspirate ocular fluids (try to avoid due to risk of disseminating malignant cells).

Management

- non-surgical management:
 - EUA
 - systemic, intra-arterial or intra-theical chemotherapy
 - local therapy: cryotherapy, laser photocoagulation, thermotherapy or plaque radiotherapy
 - external beam radiotherapy.
- surgical management:
 - enucleation (need to remove a long segment of the optic nerve).

Pre-operative preparation

- dilate the pupil.

Instruments

- see EUA section
- see enucleation section.

Complications at time of surgery

- for enucleation, failure to remove a long segment of the optic nerve can lead to spread of the tumour beyond the eye.

Complications after surgery

- external beam radiotherapy: craniofacial deformity, secondary tumors.

Examination Under (general) Anaesthetic (EUA)

EUA is not a condition but a procedure.

Indications for procedure

Poor cooperation in the clinic (i.e. the child will not keep still long enough for a sufficient exam) and when the medical team needs more detailed eye examinations in order to diagnose or treat a child.

Examples of why this is performed

- corneal ulcer
- need for a thorough examination: e.g. Retinoblastoma and other tumors
- ocular trauma
- congenital glaucoma

Pre-operative preparation

- dilate the pupil.

Instruments

- lid speculum
- portable slit lamp
- tono-pen
- callipers or ruler with millimetre markings
- gonioscope (Koeppel lens)
- retinoscope with lenses (plus and minus lenses – lens bars work well)
- +/- pen light
- +/- direct ophthalmoscope
- indirect ophthalmoscope and 20D and 28D lens
- scleral depressor or cotton tip applicators
- fluorescein strips

- lubricating eye drops (artificial tears) and ointment (if child's eyes tend to stay open and the cornea is not well lubricated, place ointment in both eyes after the EUA and let the parents know that the vision may be blurry after the child awakens, until the ointment has melted away)
- ultrasound (A- and B-scan) with coupling gel
- keratometer
- photography (e.g. RetCam or other retinal or anterior segment imaging device).

Complications at time of surgery

- corneal abrasion – keep corneas well lubricated and do not allow them to dry out during the procedure.

Complications after surgery

- none.

Nursing considerations

As this is not an invasive procedure (which is in essence only taking place in the OT because of access to the anaesthetics' services), then there is no need for the scrub team to complete a full, surgical scrub-in, gown and drape. Depending on which specific examinations are taking place, a table drape or pair of gloves may be all that is needed. Check with local policy. Staff duties may include:

- cleaning equipment between uses
- being on standby to assist the surgeon as required.

Corneal Surgeries

The Aravind Hospital Team and Heather Machin

There are several reasons why patients require corneal surgery, and in turn, there are several different types of procedures that the surgeon can perform. Access to this surgery is heavily impacted by the accessibility of corneal tissue from an eye bank and the type of tissue cutting they can perform. Please see section 5 regarding the handling and management of corneal tissue for transplantation.

For the purpose of this text book, focus shall be on the traditional surgical approach called a Penetrating Keratoplasty (PK) which replaces a full thickness portion of the patient's cornea with that of a donor cornea from an eye bank. Readers are encouraged to learn about more advanced approaches of partial corneal layer or lamellar transplant replacement techniques which are not covered in this text book – i.e. Descemet's Membrane Endothelial Keratoplasty (DMEK), Descemet's Stripping Endothelial Keratoplasty (DSEK), and Deep Anterior Lamellar Keratoplasty (DALK), and newer technologies which are being exploring i.e. Limbal Stem Cell Therapy.

The patient is often referred to as the recipient in transplant surgery. These words are interchangeable in this section.

Penetrating keratoplasty (PK)

Indication

The aim is to remove corneal opacification and disease that is obscuring the visual axis. Common conditions are:

- Pseudophakic bullous keratopathy
- Fuchs' endothelial dystrophy
- Keratoconus
- corneal opacity and scars from old, healed infections or trauma

- failed therapeutic grafts
- infections - bacterial, fungal, parasitic, viral origin which are unresponsive to treatment
- corneal burns.

Pre-operative preparation

- constrict the pupil
 - note: if a cataract surgery also needs to be performed at the same time as the transplant (combined surgeries), then the pupil should be dilated. Check with the surgeon before dilating or constricting in this instance.

Surgical technique

- The patient is prepared as per a normal intraocular procedure – with Sign-In and Time-Out.
- The donor tissue is checked and prepared.
- The surgeon uses a corneal punch (to the size they want) with or without the use of left or right corneal scissors (depends).
- The donor tissue is cut to size. This is performed prior to surgery to ensure the tissue is ready.
- The procedure on the patient commences with an iridectomy.
- Once the patient's cornea (referred to as a corneal button) has been removed, the surgeon must act fast to place the transplanted tissue onto the space. This is because the surgeon does not want the patient to remain with a big hole in their eye for too long.
- Once in place, the cornea is sutured.
- Miochol/miostat agents may be used to help constrict the pupil at the end of the procedure.
- Antibiotic agents are administered as per the surgeon's request.

Note: it is important that the patient does not move during this delicate procedure. Particularly, it is important that the patient does not cough as this can cause the head to jerk, as well as cause potential surgical issues while the eye is exposed without a cornea. The surgeon wants to make sure the contents of the eye are not expelled (come-out) while there is a hole. This is a critical point and the nursing team needs to make sure they are vigilant and working to support the surgeon to get the new tissue in place as quickly as possible.

Instruments

- wire speculum or Jaffe speculum
- superior rectus forceps
- mosquito forceps (curved or straight) marking calliper
- corneal trephines of various diameters for the patient
- teflon block
- hand held Troutman corneal punch or other types of corneal punches for the patient
- side port blade
- viscoelastic with 23 g cannula
- injection of adrenaline (diluted) if it becomes necessary to dilate pupil
- carbachol intraocular solution to constrict pupil if necessary
- corneal scissors (left and right)
- calibre forceps or other 0.12 forceps
- castroviejo needle holder
- suture tying forceps
- iris forceps
- Vanna's scissors
- cystotome

- Sinsky hook (dialler)
- 10-0 or 9-0 nylon sutures
- 5 ml syringe
- other -depending on technique and availability
 - Flieringa Rings.

Post-operative instructions

- Post-operative patients will be prescribed eye drops and analgesic tablets.
- Education on activities and post-operative management are essential to reduce sight-altering infection and tissue rejection – i.e. no swimming, wearing contact lenses, heavy lifting or straining until notified to do so by the surgeon.
- Topical steroids can be prescribed, such as:
 - topical antifungals or antibacterials for therapeutic keratoplasty
 - topical steroid drops and broad spectrum antibiotics for optical penetrating keratoplasty.

Additional information about donor tissue and tissue preparation

Once the tissue has been checked and opened up onto the sterile field, the surgeon makes it into a size suitable for the patient's eye. They do this by using a marking and cutting device called a Corneal Punch. There are many types available (i.e. ones that are handheld, and ones that use suction). The principle is that the surgeon cuts the donor tissue to be slightly bigger than the corneal tissue that they will remove from the patient (also known as the recipient). The abnormal portion of the recipient's cornea is removed by using a trephine (which is sized smaller than the donor tissue). This makes the transplanted tissue overlap correctly and helps create a seal – which is then sutured twice over with a 9-0 or 10-0 nylon suture. One series of sutures will be taken out relatively soon post-operatively, while the other series will generally stay in place long term - until the corneal tissue has been accepted by the patient's body, i.e. the tissue has not been rejected as foreign-body by their natural defence system. Note: different surgeons have different surgical techniques. Some use a single pass, some use simple interrupted sutures, and some use combined sutures.

Donor buttons are placed onto a Teflon block so they are easy to control. The surgeon uses the corneal punch to make the size they require. The surgeon will leave it there, kept moist – most likely with some of the fluid from the donor tissue transport container, until they are ready to transplant it.

Note

- The tissue needs to be checked during Sign-In and Time-Out. Please see section 5 for an outline on how to handle and check human tissue for ocular application (transplantation).
- The donor tissue needs to be prepared BEFORE the surgeon removes the patient's cornea. This is a safety measure.

Pterygium

The Aravind Hospital Team and Heather Machin

Name of condition: pterygium

Pterygia occur due to the growth of sub-tenon tissue on and over the limbal region. They generally occur in the nasal aspect of the eye and can be both bilateral and unilateral. They can be caused due to the reflection of the sun onto the side of the nose which reflects (bounces) the sun onto that part of the eye. It is more common in countries with a lot of sun (however they can also impact people living in snowy areas as the sun reflects off the snow).

If the growth is too large it can cause discomfort to the patient as well as dryness and itchiness. This is because the pterygium raises the eyelids off the surface of the eye in some sections. These sections then dry out as they are not adequately nourished during the natural blinking process. In extreme cases, the pterygium can grow over the visual axis. While smaller pterygia could be managed by dry eye drops; surgery is also an option for larger pterygia for both comfort and cosmetic reasons.

Long-term, the wearing of sunglasses will help to prevent pterygium.

Indications for surgery

- decrease in visual acuity (either due to direct decrease in visual acuity or due to irregular astigmatism more than 1.5 dioptres)
- cosmetically significant pterygium
- symptomatic degenerative changes like cystic lesions
- discomfort due to recurrent or chronic inflammation of the pterygium
- restriction of ocular movements caused by the presence of pterygium.

Surgical techniques

In the past, in several parts of the world, the pterygium was removed through radiation plaques, which worked by placing a small metal plate – often in the shape and size of a cornea – on to the surface of the eye. The plate was attached to a machine which generated a radioactive response and it was this radioactive process which killed off the cells. While some countries may still have this technology, this is rarely used nowadays due partly to the serious long term complications that may occur as a result of the use of radiation plates, as well as the improved techniques now available for surgeons. Therefore, radiation plaques will not be discussed in this text.

Small pterygia

- The pterygia can be excised and scrapped back with a blade No 15 +/- cautery as a singular procedure or while another procedure is performed.

Large and reoccurring pterygia

- The surgery is more complex. It requires careful dissection and separation from the surface of the eye, pushing back of the conjunctiva and removal of sub-tenon tissue.
- Depending on the surgical technique, the surgeon may opt to polish the cornea with a corneal burr at the end of the procedure.
- The surgery may or may not require a conjunctival graft – it depends on how big the pterygium is. The graft can be obtained from the patient's own eye – generally the tissue just under the upper eye-lid.
- The surgery may or may not require an antimetabolite (cytotoxic) to prevent the cells from re-growing – this tends to be used on re-occurring pterygium cases and in younger patients in whom recurrence is more common.
- Ointment is generally applied post-operatively.

Pre-operative preparation

- no dilation
- apply topical anaesthetics drops
- if a conjunctival autograft is to be performed then injection of local anaesthesia to the surgical site as well as to the supero-temporal portion of the conjunctiva where the graft will be harvested, may be necessary.

Special post-operative education tips for patients

After the operation, the patient will be examined on the next day. Post-operatively the patient will be prescribed eye drops and analgesic tablets. While routine body wash and head washing can be permitted from the next day, care should be taken not to get soap and water into the operated eye until after a week. It is advisable to take rest (remaining indoors to avoid dust) for a period of a week to 10 days. This can be quite painful. Therefore an adequate supply of pain relief is advised.

Instruments

This is a basic procedure requiring very few instruments or consumables. Some facilities treat it as a minor procedure. Some basic must-have items are:

- speculum
- Colibri forceps
- Westcotts
- Vannas Scissors
- needle-holders
- blade handle and No 15 blade
- tying forceps
- calliper +/- marking pen for graft (surgeon depending)
- 8-0 Vicryl and 10-0 Nylon
- cautery
- items for antimetabolite (cytotoxics)
- local anaesthetic.

Nursing considerations

- pathology - the surgeon may request for the removed tissue to be sent to the pathologist. Please see section 5 on specimen handling and working with antimetabolites/cytotoxics.

Combined Surgeries

From time-to-time, patients require two surgeries at the same time. This may confuse a new nurse or technician because they may not know how to prepare. For example, if a patient is having a cataract and a corneal transplant at the same time, they may not know if they should dilate or constrict the pupil or which equipment to prepare first. To prevent confusion or incorrect preparation, it is recommended that for all combined surgeries, the nurse and technician checks with the surgeon (or retains a surgeon preference card) so that variations can be prepared for (i.e. time allocation, pre-operative needs, instruments and consumables, machines and so-on).

Trachoma (Trichiasis)

Kristen A. Eckert and Van C. Lansingh

Trachoma is a condition that can be prevented. In serious cases, the eyelashes turn inwards. If not treated quickly, the eyelashes can rub against the cornea and cause corneal damage (inflammation and scarring), which, in the most severe cases can lead to blindness. To prevent this, the surgeon wants to return the eyelashes to their normal position, as soon as possible, through a technique called a Tarsal Rotation. This technique will be discussed in more detail shortly.

The condition is caused due to a bacterium called Chlamydia trachomatis which can be easily spread from person-to-person. Therefore, early detection and prevention is important. The SAFE

strategy has been developed to help prevent and treat this condition.

S - Surgery

A - Antibiotics

F - Facial Cleaning

E - Environmental Improvements

For more information on SAFE please see: <http://www.trachoma.org/safe-strategy>.

Classification of trachoma

The trachoma classification defines active trachoma as the presence of follicular trachoma (TF) which occurs when ≥ 5 follicles (of at least 0.5 mm in diameter) are present in the upper central tarsal conjunctiva of the eyelid and (trachomatous inflammation (TI) is intense. This causes pronounced inflammatory thickening of the upper tarsal conjunctiva that obscures more than half of the normal deep vessels. Chronic inflammation results in scarring of the tarsal plate and conjunctiva, which turns the eyelid margin inward. (WHO, Trichiasis surgery for trachoma, 2013; Lavett et al, 2013). Trachomatous Trichiasis (TT) occurs when ≥ 1 eyelash touches the cornea, which (when left untreated) can lead to corneal opacity (CO) with vision loss and eventually blindness. Surgery is meant to correct the eyelid by rotating the eyelid margin outward and restoring moderate vision. For severe vision loss, surgery is performed in order to prevent further blindness and pain. (WHO, Trichiasis surgery for trachoma, 2013).

All patients should be offered surgery. (WHO, Trichiasis surgery for trachoma, 2013). Surgery is advised when ≥ 1 eyelash touches the cornea when the patient is staring straight ahead. There is evidence of corneal damage and severe discomfort. If a patient only has 1 or 2 eyelashes rubbing the conjunctiva only, and does not complain, alternative interventions may be considered.

Surgical techniques

Bilamellar Tarsal Rotation (BLTR) and **Trabut (posterior lamellar tarsal rotation)** are recommended by the World Health Organization. (WHO, Trichiasis surgery for trachoma, 2013; Rajak et al, 2013). In both procedures, a horizontal tarsotomy is performed with everting sutures to rotate outwards the inferior portion of the upper lid. A full thickness lid incision is made through the anterior and posterior lamellae in BLTR. (WHO, Trichiasis surgery for trachoma, 2013; Barr et al, 2014) Previously, the literature suggested that the Trabut method is easier and more suited to community-based programs, because the incision is only on the conjunctiva and tarsal plate and surgical outcomes are better with less complications. (Soares and Cruz, 2004). More recently, a new, easy-to-use TT clamp has been developed to correct the shortcomings of the BLTR procedure and prevent surgical complications, such as granuloma and eyelid formation abnormalities. (Gower et al, 2013; Merbs et al, 2013) It has been found to be safe and effective.

Note, a more complicated procedure will be needed if the eyelid does not close properly. (WHO, Trichiasis surgery for trachoma, 2013)

Duration of the procedure: 7 - 35 minutes

Post-operative complications

- oedema of the lid
- granulomas
- under corrections
- lid notches

- Eyelid closure defect.
- Buckling.

(WHO, Trichiasis surgery for trachoma, 2013; Rabiou and Abiose, 2001.)

Pre-operative management

- instruct the patient to take Ciprofloxacin 0.3% eye drops at least 3 days prior to surgery. (Rajak et al, 2012)

Post-operative management

- Immediately after the procedure, tetracycline ointment is applied to the conjunctival sac and onto the wound, and the eye is padded. A single dose of azithromycin (1gm) can protect against TT recurrence for up to 1 year. (Woreta et al, 2012)
- Adequate supplies of pain relief medication should be provided for the patient to take home; pain may occur once the anaesthesia loses effect. (WHO, Trichiasis surgery for trachoma, 2013)
- The patient should be instructed to rest at home (if possible) and return 1 day later.
- If unable to return, instruct the patient to remove the pad after 1 day and clean the wound with clean water and sterile gauze. (WHO, Trichiasis surgery for trachoma, 2013)
- After 1 day post-surgery, the pad is removed from the operated eye, and the patient should wash their eye with warm water every morning and apply tetracycline eye ointment 2-3 times daily for up to 2 weeks or until the entire tube is finished. (WHO, Trichiasis surgery for trachoma, 2013; Rajak et al, 2011; Alemayehu, 2004)
- The patient should return after 8-15 days for suture removal and wound examination. (WHO, Trichiasis surgery for trachoma, 2013)

Post-operative education – community promotion

Patients should be encouraged to share their experience and advocate for TT intervention and prevention among their friends, families, and neighbours, to help decrease the spread of the condition which can often occur due to lack of knowledge, fear and ambivalence. (Pearson et al, 2013; Nagpal et al, 2006)

Setting up for this surgery

The International Agency for the Prevention of Blindness (IAPB) has recently published their essential equipment list for TT screening and surgery, which recommends the minimum set of items required to perform high quality TT surgery. (IAPB, 2015; Balantrapu and Hoare, 2014). This equipment list is based on the 2013 updated WHO TT surgery manual-1 and the conclusions and recommendations from the 2012 International Coalition for Trachoma Control's preferred practices Global Scientific Meeting in Trachomatous Trichiasis. (International Coalition for Trachoma Control, 2012). This list recommends instruments for Trabut surgery and 2 types of BLTR surgery. Accompanying consumables, disposables, medications, and supplies are also listed below the surgical instruments. A modified list is provided in Table 2.1.

Table 2.1: Recommended instruments for TT lid procedure

Recommended Instruments for All TT Lid Surgical Procedures		
Item	Unit	Comments
Stainless Steel Sterilization Case (large)	1 piece	
Autoclave or Pressure Cooker	1 piece	
Metal Bowl 4.5L 260 mm x 125 mm	1 piece	
Kidney Bowl 0.5 L 250 mm x 36 mm	2 pieces	
Galley Pot	1 piece	
Moorfield's Suture Forceps	1 piece	
Suture & Dissecting Forceps with Serrated Ends	1 piece	
Silcock's Needleholder	1 piece	
Scissors Straight with Blunt Tips	1 piece	
Scalpel Handle No. 3	1 piece	
Additional Equipment for Alternative Surgical Procedures		
Trabut lid surgery		
Mosquito Forceps Straight	2 pieces	
Trabut Lid Plate	1 piece	
BLTR Surgery		
TT-clamp	1 piece	For Type 1 BLTR surgery with clamp only
Mosquito Forceps Straight	2 pieces	For Type BLTR surgery without TT-clamp
Consumables and Disposables		
Scalpel Blades No. 15	1 pack: 100 pieces	
Vicryl Sutures Double Armed Cutting Needle	1 pack: 12 pieces	1 double armed suture can be used per 1 patient
Either 4-0 Black Braided or Silk Suture	1 pack: 12 pieces	Alternative option to Vicryl sutures; If armed, a needle is attached. If on reel, it needs attachable and re-usable cutting eye needles, 3/8 circle.
21G Sterile Disposable Needles	1 pack: 100 pieces	1 needle per eye; 1 pack for 50 bilateral TT surgery patients
5 ml Sterile Disposable Syringe	1 pack: 100 pieces	If kept sterile, 1 syringe can be used for the same patient for bilateral surgery only under outreach conditions. 1 pack can last for 100 bilateral TT surgery patients.
Gauze Roll 90 cm X 91 m	1 pack: 10 pieces	
Zinc Strapping 2.5 cm x 5 m	1 pack: 10 pieces	
Mask and Cap for Surgeons	1 pack	
Sterile Surgical Gloves (appropriately sized)	1 pack: 50 pieces	If kept sterile, 1pair of gloves can be used for both eyes.
Sterile Drape, approximately 1 meter with a central hole approximately 10 cm x 10 cm made of linen	1 drape	1 eyelet per patient
Sterile Drape, disposable and made of sterilized paper		This is optional for campaign mode outreach due to expense only. As an alternative, use the inner paper of the gloves as a drape, by making a hole in it.
Medications and Supplies		
Tetracycline 1% Eye Ointment or Chloramphenicol 1% Eye Ointment	1 pack: 25 5 g tubes	To prevent post-operative infection, apply antibiotic ointment once, at the end of surgery, before patching the operated eye.
Azithromycin Tablets 250 mg (as available and indicated)	1 Bottle: 500 tablets; blister packs of 4 tablets are also available for purchase	To reduce the risk of Chlamydial infection recurrence, 1 dose (4 tablets/adult) of Azithromycin should be administered around the TT surgery. If unavailable or if treating ineligible patients (i.e. pregnant women), use Tetracycline eye ointment for a full 6 week treatment course or Azithromycin eye drops.
Azithromycin Dihydrate 200 mg Base 5 ml Suspension	1 bottle 30 ml	Indicated for very young children with TT only, who will need general anaesthesia. The average needed is 15 ml per child.
Amethocaine hcl 0.5% Eye Drops (or similar topical anaesthetic)	1 bottle 10 ml	1 bottle per approximately 20 patients
Lignocaine 2% hcl + adrenaline	1 bottle 50 ml	1 bottle per approximately 10 patients; 2.5 ml per eye
Povidone Iodine 10% Solution 200ml - Skin Preparation		1
70% Alcohol		1
Sterile Distilled Water or Normal Saline		1

References

1. World Health Organization (WHO). Trichiasis surgery for trachoma. Update from Final assessment of Trichiasis surgeons, and Trichiasis surgery for trachoma, the bilamellar tarsal rotation procedure (WHO/PBL/93.29). WHO; 2013. http://apps.who.int/iris/bitstream/10665/101430/1/9789241548670_eng.pdf. Accessed 1st July, 2016.
2. Lavett DK, Lansingh VC, Carter MJ, Eckert KA, Silva JC. Will the SAFE strategy be sufficient to eliminate trachoma by 2020? Puzzlements and possible solutions. *ScientificWorldJournal*. 2013; 2013:64810.
3. Rajak SN, Habtamu E, Weiss HA, Kello AB, Abera B, Zerihun M, et al. The outcome of trachomatous trichiasis surgery in Ethiopia: risk factors for recurrence. *PLoS Negl Trop Dis*. 2013; 7(8):e2392.
4. Barr K, Essex RW, Liu S, Henderson T. Comparison of Trichiasis recurrence after primary bilamellar tarsal rotation or anterior lamellar repositioning surgery performed for trachoma. *Clin Experiment Ophthalmol*. 2014; 42(4):311-6.
5. Soares OE, Cruz AA. Community-based transconjunctival marginal rotation for cicatricial trachoma in Indians from the Upper Rio Negro Basin. *Braz J Med Biol Res*. 2004; 37(5):669-74.
6. Gower EW, West SK, Harding JC, Cassard SD, Munoz BE, Othman MS, et al. Trachomatous Trichiasis clamp vs standard bilamellar tarsal rotation instrumentation for Trichiasis surgery: results of a randomized clinical trial. *JAMA Ophthalmol*. 2013; 131:294-301.
7. Merbs SL, Kello AB, Gelema H, West SK, Gower EW. The trachomatous Trichiasis clamp: a surgical instrument designed to improve bilamellar tarsal rotation procedure outcomes. *Arch Ophthalmol* 2012; 130(2):220-3.
8. Rabi MM, Abiose A. Magnitude of trachoma and barriers to uptake of lid surgery in a rural community of northern Nigeria. *Ophthalmic Epidemiol*. 2001; 8(2-3):181-90.
9. Bowman RJ, Faal H, Myatt M, et al. Longitudinal study of trachomatous Trichiasis in the Gambia. *Br J Ophthalmol*. 2002; 86:339-43.
10. Rajak, SN, Collin JRO, Burton MJ. Major Review: Trachomatous Trichiasis and its management in endemic countries. *Surv Ophthalmol*. 2012; 57:105-35.
11. Woreta F, Munoz B, Gower E, Alemayehu W, West SK. Three-year outcomes of the surgery for Trichiasis, antibiotics to prevent recurrence trial. *Arch Ophthalmol*. 2012; 130(4):427-31.
12. Rajak SN, Habtamu E, Weiss, HA, et al. Absorbable versus silk sutures for surgical treatment of trachomatous Trichiasis in Ethiopia: a randomized controlled trial. *PLoS Med*. 2011; 8:e1001137.
13. Alemayehu W, Melese M, Bejiga A, Worku A, Kebede W, Fantaye D. Surgery for Trichiasis by ophthalmologists versus integrated eye care workers: a randomized trial. *Ophthalmology*. 2004; 111(3):578-84.
14. Pearson K, Habte D, Zerihun M, King JD, Gebre T, Emerson PM, et al. Evaluation of community-based Trichiasis surgery in Northern Ethiopia. *Ethiop J Health Sci*. 2013; 23(2):131-40.
15. Nagpal G, Dhaliwal U, Bhatia MS. Barriers to acceptance of intervention among patients with trachomatous Trichiasis or entropion presenting to a teaching hospital. *Ophthalmic Epidemiol*. 2006; 13:53-8.
16. International Agency for the Prevention of Blindness (IAPB). IAPB Essential Equipment List for screening and surgery for Trachomatous Trichiasis. IAPB Essential Lists. IAPB 2014. http://iapb.standardlist.org/uploads/2/5/4/3/25435253/iapb_trachoma_standard_list_final.pdf. Accessed 1st July, 2016.
17. Balantrapu TV, Hoare PJ. The International Agency for the Prevention of Blindness (IAPB) Launches Essential Equipment List for Screening and Surgery for Trachomatous Trichiasis. *Ophthalmic Epidemiol*. 2014 Aug 7:1-2. [Epub ahead of print]
18. International Coalition for Trachoma Control. Global Scientific Meeting on Trachomatous Trichiasis. Meeting discussions, conclusions & suggested research. Moshi, Tanzania; 30th January – 1st February, 2012. <http://trachoma.org/sites/default/files/guidesandmanuals/Meeting%20on%20TT%20English.pdf> Accessed 1st July, 2016.

SECTION 3

Emergency Triage for Surgery and Ocular Hospital Acquired Infections and Inflammatory Conditions.

Contributors: Hunter Cherwek and Janet Marsden



This section provides an overview of some critical issues specific to eye care, including prioritising presenting patients who need urgent eye surgery (this will exclude triage of non-surgical issues). Additionally this section will discuss some common ocular infections and inflammatory conditions that result in blindness. Prevention will also be discussed.

Emergency Triage for Surgery

The urgent surgical patient

There are a number of ophthalmic presentations which will need surgery. This section will consider how they present to the emergency department, and their subsequent care and potential pre-surgery needs.

In order to do this, the nurses and doctors in the emergency department need to know “what to look for” when triaging. Juggling eye emergencies against other issues (e.g. fractures or heart attacks) is also a challenge, but for the purpose of this text, we will only be exploring ocular emergencies. It is recommended that further study and training in other medical areas is undertaken by nurses working in general emergency departments.

Triage

Emergency departments which have more patients arriving than they can comfortably deal with, often use a system called Triage. Triage is a process of sorting patients, who present to an emergency department, in a manner that can help decide which patient needs to be seen more urgently than another. Its key benefit is to manage the risk to patients who are waiting to see a clinician - by ensuring that those who need the most urgent care and treatment are looked after before those who shout the loudest. This is a part of risk management and prevention and ensures a patient's medical status does not deteriorate due to the systems inability to manage patient priorities.

The aim, through a Triage System, is to prevent further injury, maintain as much of a patient's current vision as possible and, at best, improve their vision and qualities of daily living.

How triage works

Triage can be undertaken in a number of ways, from a simple, three category system such as “This patient needs to be seen ... NOW ... SOON ... LATER” or via a much more complex system.

What is required is a system where the same patient would be triaged identically (i.e. to the same outcome), regardless of who was undertaking the triage, rather than relying only on the judgment of an individual. This is called a ‘reproducible’ system. It also needs to be robust, safe and evidence-based.

In England, a group of emergency nurses and doctors developed a system called The Manchester Triage System for local use, and it has now become the most widely used triage system in the world - with good evidence to support its outcomes. It is based on the premise that every presentation is life or sight threatening until proved otherwise, so that the less obvious is not missed. It is a 5 category outcome system relating to the time it takes to see a clinician.

The EYE PROBLEMS chart (Diagram 3.1), is an example of the Manchester Triage System. Each discriminator (i.e. the phrases in the boxes) is defined in the same way, ensuring there is universal meaning to the nurses and doctors using them. This helps promote universal levels of service, no matter who the patient is, or who the clinical staff member is.

As seen from the diagram, (which is algorithm –flowchart – based), the person assigned to do triage needs to be experienced in ophthalmic care in order to use it correctly. This chart is part of a

whole system. Other useful charts specific to the ophthalmic setting (i.e. visual acuity chart) and non-ophthalmic specific charts (i.e. to suit patient presentation, such as facial injuries and the unwell adult) can also be used alongside the algorithm to provide more reference points for patient triage.

Triage is not about diagnosis, but about managing the sight risk of the patient waiting for treatment. It helps by ensuring that there is an understanding of how the patient presents, and how decisions impact the treatment plan and outcome.

The person triaging, ALWAYS starts at the top of the chart and asks the patient a series of appropriate questions, in order to move them down the chart. The FIRST discriminator (matching a patient's status to the chart) is used to decide the patient's priority for treatment.

Note: always make sure any of the patient's prior (old) notes are available so their current presentation can be compared with their previous episode of care.

Understanding the coloured box system

The Manchester Triage System uses a colour spectrum concept of Red, Orange, Yellow, Green and Blue.

RED - the most urgent condition requiring fast triage

On the EYE PROBLEMS chart, the most important presentation requiring fast treatment, is a chemical injury - it is immediately sight threatening, and if not treated straight away, the eye will experience further damage. Determining if the patient has a chemical injury will be supported by the information from the patient, i.e. how their injury occurred. If the patient does not fit the Red outcome category, the triage person can start to move down the chart.

Orange – other types of urgent issues

The Orange outcome box includes patients presenting with urgent conditions that do not fit into the Red category. It is important in considering whether a patient has a penetrating eye injury, e.g.:

- Severe pain (8-10 on a 10 point scale) - whatever the reason for the pain, the patient needs investigating and treating, even if treatment is as simple as a drop of topical anaesthetic.
- Sudden complete loss of vision which may or may not be traumatic, but needs urgent assessment.
- A hot baby - if the skin is hot, or a temperature of 38.5 degrees Celsius and above combined with an eye issue, needs care quickly.
- Adults with a temperature of 41 degrees Celsius or above (which is considered very hot), also need to be seen quickly, as their rise in body temperature (medically termed as Pyrexia) may be a result of a severe infection.
- It is important that patients in the Orange category are seen by an eye specialist, or the person who can start treatment very quickly. The Manchester Triage System says that this should be within 10 minutes of arrival.

Yellow

The YELLOW outcome box is associated with a wait of no more than an hour' and includes those in moderate pain (5-7 on a 10 point scale), those with any recent loss of vision, and the pyrexial adult. The inappropriate history discriminator refers to a situation

Diagram 3.1: Manchester Triage System's Coloured Flowchart

(Mackway-Jones, Marsden, & Windle, 2014)

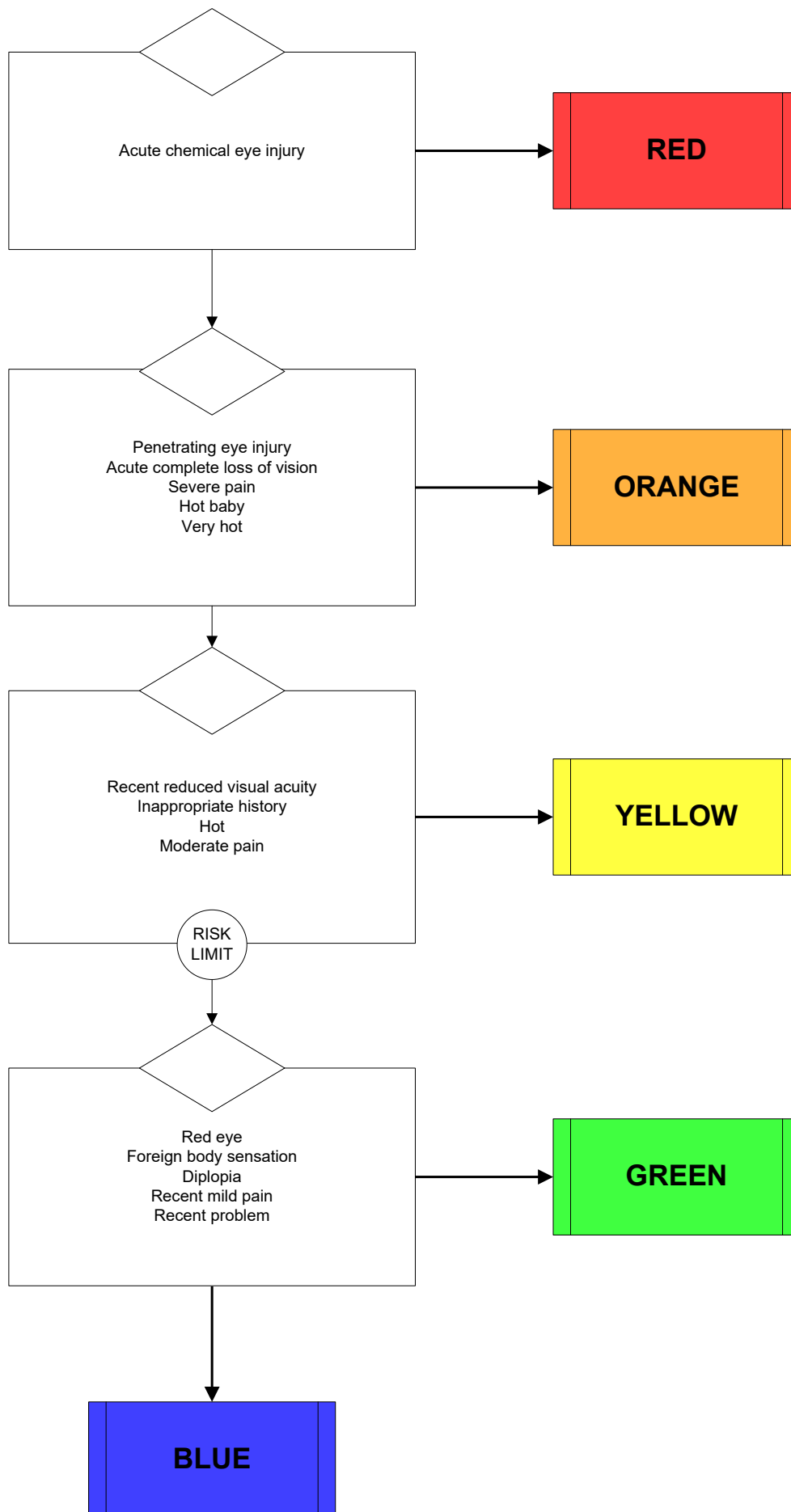

where the history provided does not match what the triage person is observing in the presenting patient. It can be an indicator of abuse.

Green

The GREEN outcome box catches almost anything else unless the person has had a stable problem for more than a week. This does not mean that they do not need care, just that their needs are not as urgent as others.

After the colour group has been determined

When examining an eye in the emergency department, where there has been trauma of any sort, always assume the worst. Therefore, assume the eye is "open" (ruptured) until an examination determines that it is not.

For a person with an open eye, or open structures around the eye, due to immediate injury or complications of previous surgery, there is a likelihood that they are going to need surgery. The care given to these patients in the emergency department is very important in getting the best outcome for the patient. Here are some general rules for working with ocular emergencies.

General key messages for immediate care of presenting patients

Do not

- Put preserved drops in the eye - preservatives are toxic to the intraocular tissue.
- Put ointment on or in the eye - ointment is toxic to the intraocular structures.
- Put pressure on the eye if it is open. Ocular contents can be lost if pressure is put onto the globe. Instead, when examining the eye, the lids can be opened by lifting the lid and pressing it against the brow or cheekbone, rather than the eye itself. This is best practice, because in some cases the lids can be swollen. This is important as the person examining may have no idea what is under the closed lids and needs to be careful not to cause harm.
- The eye should NEVER be padded because of the risk of pressure on the globe as well as the risk of material from the pad being transferred to the wound. The aim is to prevent any further damage, while preserving as much tissue as possible, so avoid this.
- Cover the fellow (other/uninjured) eye. This renders a previously seeing person as completely blind and could be very traumatic for them. Note: covering both eyes will not stop either eye moving as the patient is likely to move the eye more, as they search for light and attempt to see.

Do

- Cover the injured eye with a plastic eye shield, or with the bottom part of a paper or plastic cup or small bottle with its top part removed.
- Consider whether an unpreserved antibiotic should be instilled into the eye;
 - one of the enemies of a good visual outcome is infection, so early instillation of antibiotics is a good idea.
- Position the patient upright – this minimises the intraocular pressure build-up which might allow ocular contents to escape;
 - if they are unwell, or in pain, it is appropriate to make them comfortable on a bed or trolley. If possible, they should be positioned in a head-up position at no less than 30 degrees, because if left lying down, the intraocular pressure increases.

- Ensure the patient is kept nil-by-mouth which means fasting (not letting them eat or drink) in case they need to fast for surgery - at least until a decision has been made about a definitive treatment.
- Obtain an appropriate order for pain relief (bearing in mind that it is likely to be given by an alternative route other than the oral route) if the patient experiences pain.
- Provide the patient with good information about what is happening at all points in the process in order to minimise fear and enhance cooperation.

General key messages for presenting lid trauma when the globe is intact

Do not

- Use ointment as this can slow wound healing if it contaminates the lid tissue.

Do

- Protect the globe as much as possible by moving the lid tissue into its normal anatomical position as far as is possible, perhaps taping wound edges together to keep the globe covered.
- Use artificial tears if the cornea is exposed, to keep it moist until the lid can be repaired;
 - if the cornea dries out, it can cause lasting damage with consequent vision loss.
- Consider wound toilet (cleaning), if the lids are contaminated, but do not remove any tissue in the process;
 - there is little to spare on the lids and a good anatomical result is important to protect the globe.
- Protect and keep the wounded lid area moist by means of a sterile, gauze dressing soaked in normal saline. This will also preserve the lid tissue while waiting for surgery. No pressure should be placed on the dressing.
- Try and delay doing immediate surgery because the lids are highly vascularised. It is better to delay until specialist care is available rather than to do immediate surgery that could result in a poor repair.
- Ask about the immunisation history of the patient so that anti-tetanus vaccine may be administered if necessary.

For patients requiring surgical treatment

- The patient should be kept 'nil-by-mouth' at least until a decision has been made about the definitive treatment.
- If the patient is in pain, appropriate pain relief should be obtained, bearing in mind that it is likely to be given by a route other than the oral route.
- The patient needs good information about what is happening at all points in the process in order to minimise fear and enhance cooperation. Eye injury is very frightening and appropriate information at the appropriate time can alleviate fear.
- A complete medical history, including any medications and allergies as well as a full set of observations, is useful for the anaesthetist and the clinicians who are going to care for the patient after they leave the emergency department.
- Relatives need care as well. Information can be given to them with the consent of the patient.

Ocular Hospital Acquired Infections and Inflammatory Conditions (Endophthalmitis and Toxic Anterior Segment Syndrome)

Endophthalmitis

Endophthalmitis is defined as an infection inside the eye, often following a penetrating injury or an intraocular surgical procedure. This can be caused by bacteria (the most common) or fungi - and rarely - parasites. Endophthalmitis can also, rarely be “endogenous” which means infection can get into the eye through the blood.

Presentation

Patients can begin to have signs and symptoms of endophthalmitis on the first post-operative day after intraocular surgery (i.e. cataract surgery) - however some delayed cases may not present for weeks after surgery. This is often determined by the type of micro-organism causing the infection. Careful and regular post-operative examination with thoughtful patient education - informing the patient of the signs and symptoms - is necessary as they may need to report back to the hospital/doctor at home. This is critical to ensuring that proper diagnosis and management of endophthalmitis can be as quick as possible and prevent long term issues and ongoing hospital care.

Signs and symptoms

- severe pain
- sudden reduction in visual acuity
- eye is red and with conjunctival chemosis
- hazy cornea
- evidence of inflammation in the eye with possibly no view of the fundus (a subsequent B-scan ultrasound is often used in this work-up, to assess vitritis and retinal detachment)
- hypopyon- layered white blood cells in the anterior chamber.

Risk factors and causes

The incidence of endophthalmitis after cataract surgery is often reported to be between 0.13 - 0.7% but can be much higher when risk factors are present and/or proper precautions are not taken.

Patient risk factors

- Inadequate management and preparation of the patient pre-operatively. This includes;
 - uncontrolled blepharitis
 - conjunctivitis
 - lacrimal duct obstruction with infection in the conjunctival sac.
- Eyelid abnormalities – presence of entropion.
- Inadequately managed infections in other parts of the body, such as a urinary tract infection or abscesses and, especially in patients with poorly controlled diabetes mellitus. These are risk factors for endogenous endophthalmitis, in which infection to the eye is acquired from within and is not associated with any intraocular surgery. Culture and sensitivity of the blood and vitreous will reveal the same pathologic organism. This has poorer prognosis than post-surgical endophthalmitis;
 - In addition to the usual medical and surgical management, immediate referral to the specialist for co-management is best, as well as identifying the primary infection site.

Surgical risk factors

- poor surgical preparation (for example, not using topical 5% povidone-iodine) and poor draping of eyelid/eyelashes. Antisepsis is critical
- poor surgical scrub, unsterile gloves, and inadequate maintenance of the sterile field
- inadequate cleaning and sterilization procedures
- prosthesis (implantable material) such as Intraocular Lenses (IOLs). Note: silicone IOLs are at higher risk of endophthalmitis than acrylic IOLs
- poorly constructed and/or leaking cataract wounds
- prolonged and complicated surgery
- poorly managed surgery.

Common causative organisms

- gram positive, coagulase negative cocci (mainly staphylococcus epidermis which accounts for ~70% of culture positive cases)
- staphylococcus aureus ~10% of culture positive cases
- streptococcus & enterococcus
- gram negative bacteria (including pseudomonas aeruginosa)
- fungi (candida, aspergillus, and fusarium).

Preparing a patient presenting with endophthalmitis

A suspected case of endophthalmitis should be treated as an ophthalmic emergency. Often, patients are admitted to the hospital for “work-up” (preparation) and treatment. This is especially important when concerns for poor patient follow-up are anticipated.

It is important to determine if the hospital/clinic has the ability to perform an analysis (including microscopy, gram stain, cultures and sensitivities, and even PCR when available). If not, steps to provide these services need to be put in place, long term. These are important for helping to determine a diagnosis (explanation of what is happening) particularly of the aqueous and vitreous. To obtain a diagnosis, the surgeon will extract a sample of fluid from the anterior and posterior chamber, through a process called a “Surgical Tap” or “Vitreous Tap”. The results of the Vitreous Tap will help guide the surgeon to select the best treatment, such as an antibiotic therapy. This will also help them confirm which organism caused the infection. When antibiotics are injected at the same time, this can be done through a procedure commonly referred to as a “Tap and Inject”.

If there has been no improvement within 24 hours after treatment, the surgeon may consider doing a second Vitreous Tap (sample) and follow-up with injections of antibiotics.

Treatment

Timely diagnosis and treatment are critical in order to help avoid devastating outcomes. Ideally, patients should receive treatment within 1 hour of diagnosis. Many hospitals and surgical teams have an Endophthalmitis Kit in the Facility. This has been prepared, ready to be pulled-out for emergency endophthalmitis treatment.

The Endophthalmitis Kit has all of the required materials and medicines to perform the Tap and Inject, and is a minimum standard kit recommended by health professionals. To build a Kit, it is always best to consult a physician (i.e. Ophthalmic Head of Department/ Medical Director), in order to make sure it has everything for such an emergency.

Around the world, the general choice of antibiotics tends to be, for example; Vancomycin 1mg in 0.1mL and Ceftazidime 2mg in 0.1

ml. The injection should be performed slowly into the mid-vitreous with a 25 or 30 G needle under sterile conditions by the treating physician. Surgical assistance can be provided by the nurse and technician teams.

Scheduling the treatment

A simple anterior Tap and Inject can be performed via a full vitrectomy surgical set-up or as a stand-alone minor-procedure - depending on the degree of anticipated infection. Either way, scheduling this surgery needs to be done with careful consideration, to simultaneously prevent cross-contamination. Ideally, place the patient at the end on the surgical list, while keeping in mind the urgency of this procedure and the need to commence injections as soon as possible.

Depending on hospital policy, the procedure may need to be done immediately and cannot wait to be added to the end of a list. This may go against normal practice for emergencies or infection cases which are routinely placed at the end of the list, and this may cause confusion for the team. Policy needs to be carefully developed around this type of urgent emergency, and needs to be done in consultation with the Director or Nursing, Medical Director and Infection Control Representative.

All procedures take place using sterile precautions and while wearing personal, protective equipment. Any collected samples also need to be sent to the pathologist as quickly as possible (and without cross-contamination).

After the procedure, the cultures and sensitivities from the vitreous tap can later confirm which organism is causing the infection and which antibiotics are indicated in treatment.

Management plan in the OT

- Prepare the eye with Povidone Iodine and position the lid speculum.
- Perform an anterior chamber and vitreous tap for microbiology with subsequent injection of Intravitreal Antibiotics (as outlined in Table 3.1), with consideration of;
 - duration of procedure, i.e. 30 minutes
 - type of anaesthesia, i.e. local.
- Consider referral to a retina specialist (if available) for an opinion regarding a full vitrectomy.
- Consider aggressive (strong) topical antibiotic therapy post-operatively (for example, vancomycin 5% and ceftazidime 5% hourly).
- Consider starting topical or systemic steroids when it is clear the infection is improving and under control.
- Observe the patient, regularly and carefully, to monitor response and possibly the need for a second tap and injection of antibiotics.

Table 3.1: Intravitreal antibiotic activity and dosage

Amikacin	0.4 mg	Gram negatives and pseudomonas
Gentamicin	0.1 mg – 0.2 mg	Gram negatives and pseudomonas
Cephazolin	2.0 mg	Gram positive
Vancomycin	1.0 mg – 2.0 mg	Gram positive
Amphotericin	0.005 mg	Fungi
Miconazole	0.01 mg	Fungi

Making up intravitreal injections

The surgical team should know in advance which topical, as well as intravitreal antibiotics, are available in the hospital pharmacy and ensure they are ordered, and readily available.

Some antibiotics require careful dilution, (special compounding) or additional instructions. For example, vancomycin and cefuroxime (or ceftazidime) should be drawn up in separate syringes and needles - they must not be drawn up in the same syringe. It is important not to re-use syringes or bottles and avoid use of drugs with preservatives (if possible). Ideally, all prepared antibiotics could be made under sterile conditions by a trained pharmacist. If this is not possible, work with the team (Director of Nursing, Medical Director and Educators) to develop a policy and procedure to guide staff to safely prepare the antibiotics ready for the physician to administer. In all instances, preparation and administration needs to be done in a sterile manner.

Here is a list of common drugs (medications) prepared for a Tap and Inject, including their most common preparation.

Please note – the below is a guide only. It is advised that the Medical Director (or Ophthalmic Department Head, or immediate physician – depending on the hospital) confirms the type and dose suitability before proceeding.

Amikacin dose: 0.4 mg in 0.1 ml

- take 1.0 ml from a vial of Amikacin at 40 mg/ml. If this preparation is not available, start with a vial of non-preserved Amikacin containing 250 mg/ml. Aspirate 1.6 ml and make up to 10 ml using normal saline. This will result in a 40 mg/ml solution
- make up the 1 ml to 10 ml using normal saline solution
- discard 9 ml from the syringe and make up the remaining 1 ml to 10 ml in the syringe with normal saline
- transfer solution from the syringe to a sterile galley pot using a 1 ml syringe, draw up 0.1 ml = 0.4 mg.

Note: Amikacin is not widely available.

Gentamicin dose: 0.1 mg – 0.2 mg in 0.05 – 0.1 ml

- take 0.5 ml from an ampoule or vial of Gentamicin at 40 mg/ml.
- make up to 10 ml with normal saline in a syringe = 2.0 mg/ml.
- 0.1 ml of this solution = 0.2 mg.

Note: this is not recommended if other preparations are available. Gentamicin can be retina-toxic.

Cephazolin/Vancomycin dose: 1.0 – 2.0 mg in 0.05 – 0.1 ml

Reconstitute a 500 mg vial with 8 ml of normal saline

- withdraw entire contents and make up to 10 ml with normal saline = 50 mg/ml
- inject 2 ml back into vial and add 3 ml of normal saline = 20 mg/ml
- 0.1 ml of this solution = 0.05 mg.

Amphotericin dose: 0.005 mg in 0.1 ml

Reconstitute a 50 mg vial with 10 ml of water for injection.

- withdraw 1 ml and make up to 10 ml with water for injection = 0.5 mg/ml

- discard 9 ml and make up remaining 1 ml to 10 ml with Dextrose 5% = 0.05 mg/ml
- 0.1 ml of this solution = 0.005 mg
- alternatively, inject entire contents of a 50 mg ampule into a one liter bag of Ringer-lactate and 0.1 ml of this contains 5 mcgs (0.005 mg).

Miconazole dose: 0.01 mg in 0.1 ml

Take 1 ml of an ampoule of IV Miconazole 10 mg/ml.

- Make up to 10 ml with normal saline = 1 mg/ml
- Discard 9 ml and make up remaining 1 ml to 10 ml with normal saline = 0.1 mg/ml
- 0.1 ml of this solution = 0.01 mg.

Toxic Anterior Segment Syndrome (TASS)

Toxic Anterior Segment Syndrome (TASS) is different from endophthalmitis as it occurs usually within 12-48 hours after cataract surgery (i.e. the onset is usually quicker). It is an inflammation rather than an infection but the results can be just as devastating to the eye and vision.

It causes a sterile (non-infectious) acute inflammation of the anterior chamber of the eye. It has been related to (caused by) many factors including:

- medications
- irrigating solutions used during surgery
- issues surrounding the cleaning and sterilization of instruments (including heat stable endotoxins from overgrowth of bacteria in water baths of ultrasonic cleaners and the build-up of particles on instruments due to inadequate cleaning in between cases)
- the presence of preservatives in solutions used intraocularly
- metallic precipitates.

Clinical examination often reveals a diffuse (wide spread) limbus-to-limbus corneal oedema with increased anterior segment inflammation. It is always Gram Stain and culture negative and typically responds well to aggressive topical corticosteroid treatment. Occasionally, when topical steroids do not suffice, systemic steroids may have to be administered.

If untreated, severe TASS can result in tissue damage leading to irreversible corneal oedema and glaucoma. Corneal transplant and glaucoma surgery may be necessary.

Until it is confirmed there is no infection, the treating physician may initially consider similar tap and injection treatment plans mirroring those used for endophthalmitis.

Prevention of both these complications of surgery is much easier than attempting to cure it later. Accordingly, procedures and protocols designed to prevent or at least significantly reduce issues, should be in place.

For further information

- Section 1: 5 Moments of Hand-Hygiene
- Section 5: Infection Control.

References

1. Mackway-Jones, K, Marsden, J., & Windle, J. Emergency Triage 3rd edition. (2014). Wiley Blackwell, London.

SECTION 4a

Care of the Surgical Patient – Communication, Pre-Arrival and Pre-Operative (and Biometry).

Contributors: Heather Machin, Mariano Yee Melgar, Fiona O’Sullivan, and Marilyn Watkins-Ramdin



The process, before and after a patient enters the OT is important. Care and planning starts before the patient even arrives at the facility and continues until the patient has been discharged. The pre- and post-operative care is managed by specially trained ophthalmic nurses and technicians who are familiar with the needs of the patient during these phases.

This section explores the role and importance of the pre-operative process, inclusive of patient communication, counselling and admissions. It will also discuss biometry, as many nurses around the world are responsible for calculating intraocular lens power during the pre-operative planning phase of patients scheduled for cataract surgery.

Section 4b will continue with an exploration of anaesthetic care, recovery and discharge.

Building Relationships, Communication and Trust

Health care facilities can often appear very busy and patients sometimes feel that they do not have the time to ask questions. Time spent engaging with a patient will help alleviate many of their worries. Preparing the patient may include repeating or re-emphasising information provided, in order to ensure that they understand the steps that are about to occur.

Important principles for patient communication and education include:

- keeping it simple
- not lecturing them. Instead encourage and engage them in discussion
- use language they understand. This includes making sure not too much medical language is used as this might not be helpful
- invite questions
- have the patient repeat instructions back or give a demonstration.

Considerations for visually impaired patients and those with special needs

As outlined in section 1, persons with a disability such as vision impairment, require special care and support. Time must be taken to set up an environment to prevent injury, and to build a supportive relationship, where the patient is comfortable discussing personal issues (i.e. health and social history), and feels comfortable asking questions.

Helpful hints are:

- Introduce yourself.
- Clearly explain the reason for the visit, conversation or examination.
- Describe the basic layout of the room to the vision impaired patient.
- Identify and introduce any other people in the area.
- Remove unnecessary noise or activity as this may distract the patient during vital parts of the conversation.
- Do not leave the room without telling the patient.
- Notify the patient prior to moving them to another spot. Describe why and where you need to move them to and then guide them to that spot.
- Ask the patient if they have any questions, or need anything, before exiting the room.
- Provide written information which can be used as a reference back-up or referral (or if they are unable to read it, as it can be read back to them by their next-of-kin). This will prevent them from having to worry about remembering everything (Shaw, 2010).

Good communication and interaction

Good communication and interaction between staff and patients is essential at all times and can be especially challenging if the patient has vision and/or hearing impairment, or aphasia. All instructions (expectations) should be clear and concise and take into account the patient's possible limitations in understanding. This may include the patient's physical and intellectual ability to understand, as well as the psychological and social state of the patient, at the time of the procedure (Shaw, 2010).

Patient counselling

The education of patients, prior to any surgical intervention, is important because the process can be frightening. Prior knowledge about the surgical process can provide some reassurance to the patient and relieve anxiety.

A patient must be fully informed of all benefits and risks associated with their surgical procedure. They should be aware of "Why", "When" and "What" type of surgery they are scheduled for, as well as any restrictions for their post-operative care. This assists the patient and family members in making informed decisions in relation to their treatment. The family member/caregiver (next-of-kin) role is also an important aspect in patient counselling and care, as their support can help the patient feel more at ease. It can also be helpful for the nurse, because family members can help educate and care for the patient. Family members can ask questions that the patient might have missed, which will later assist with better compliance and post-operative care (Pickett, 1999; Weinstock, 1992). They can also help the patient adhere to a post-operative treatment schedule (i.e. help administer post-operative eye-drops).

Patient counselling assists the patient to form realistic expectations of their surgical outcomes. It is an opportunity to reinforce what they have been told by the surgeon, especially if they have other underlying conditions that affect, or have the potential to affect, the health of their eyes e.g. glaucoma or diabetes (Duvall, Lens & Werner, 1999).

Involving the surgeon in the patient counselling process is fundamental. Their knowledge of the patient's history and anticipated surgical outcomes is invaluable. The nurse must support the surgeon by providing the opportunity to sit and chat with the patient beforehand. They can discuss expectations in relation to surgical outcomes; major components of the surgery that is consented/scheduled to be performed; the pros and cons of that surgery type (and anaesthetic), including negative aspects; and provide the patient with an outline of the expected outcome - based on their individual condition. This aspect of counselling is part of a surgeon's responsibility and provides the patient with all of the facts before they consent. This is called Informed Consent - which will be discussed shortly.

Biometry – for cataract surgery patients only

Biometry is the mathematical calculation used to determine the eye's axial length. The surgeon needs to know the axial length so an

appropriate Intraocular Lens (IOL) can be selected for implantation during cataract surgery (Frazier Byrne, 1995).

Successful post-operative visual outcomes depend on the accurate calculation and subsequent selection of the IOL. If it is not calculated correctly the patient may have to return to surgery for a lens replacement. This could cause anxiety for the patient and increase the risk of potential secondary surgical complications (as well as placing additional resource burden on the entire team). Alternatively the patient may have to be prescribed glasses – which may be disappointing for them.

While there have been many advances in technology, and there are many machines on the market to complete the calculations, biometry requires precision and good judgment on behalf of the eye care professional. Some important tips to achieving a good calculation, using an A-scan machine, include:

- Establishing a good rapport with the patient.
- Recording their medical and visual history.
- Trying to understand the patient's expectations, i.e. some people who have been myopic for a long time may like to retain a small degree of myopia. There are some people who are already used to having monovision (one eye for distance and one eye for near) and feel this is of benefit to retain. Therefore, always discuss with the patient how they would like their vision to be after the surgery.
- Discuss the possible outcomes, i.e. explain that even after all the measurements and calculations they may still require glasses.
- Pay attention to their medical history and in particular if they had trauma, corneal scars or big pterygia:
 - for a larger pterygium: The surgeon may prefer to remove it prior to conducting the biometry test. This is because the pterygium can disturb the calculation.
 - note: Keratometry Reading (K-Reading) – which is a measurement of the power and curve of the cornea, may be preferred however the axial length will still be required to calculate the IOL power.
 - note the aphakic status or the presence of an IOL, or prior retinal surgery (and silicone oil).
- If the patient has high myopia, try to achieve a good fixation. Sometimes these patients have staphylomas and the anatomical axis may be different from the optical axis while the patient is fixated on a target.
- Always establish a protocol and guideline for biometry at the facility. It will help to avoid mistakes, help make the process faster and maintain competency in this skill.
- Record all the information, including the K-Readings, so the surgeon can analyse the results, then decide on a surgical plan, and determine the best place to make the incision to minimise the residual astigmatism.
- Try to avoid applanation biometry, since this may compress the cornea (if not performed correctly) resulting in inaccurate calculations. Most of the scans can use a scleral shell (prager shell, i.e. Immersion A-scan).
- Always measure both eyes and if asymmetry is determined in the K-Reading or in the axial length, repeat the test and analyse the data;
 - check history for anisometry, corneal scars, pterygia, etc.
- Note: not all “premium intraocular lenses” are for everybody. Patients who had myopic refractive surgery will do better with intraocular lenses that do not induce spherical aberration or lenses that induce positive spherical aberrations. The same may apply for persons with keratoconus.
 - Always check the spherical aberrations found on the

corneal topography and check the spherical aberrations the IOL may induce according to the manufacture.

- Always adjust the A-constant accordingly, to match the IOLs available and/or the specific surgeon's IOL preference. If the device does not have this capability or if the technology is not available, the A-constant may need to be personalised. This can be achieved by, for example:
 - giving a “personalised” calculation of 119.0 to the surgeon with an average error of – 0.50 D, when using a particular type of IOL with an A-constant of 118.5.
- Never do a biometry in a hurry. It is always better to spend a few more minutes rather than have a patient unhappy for the rest of their life.

(Frazier Byrne, 1995)

Note: for children, testing and calculations may be far more complex and should be performed by someone trained to perform these tests on children.

Pre-Operative Care

Before the patient arrives

Preparation begins a long time before the patient arrives for their scheduled surgery. The process starts in the clinic (and at times, the emergency room) where the patient receives a diagnosis and a recommendation for surgery. The assigned surgeon will then obtain the patient's consent for surgery. It will then be necessary, via the clinic reception, to schedule the patient on the next appropriate OT list. It is also during this “scheduling time” that the clinic nurse is responsible for providing the patient with all their pre-surgery information.

An alternative method of pre-operative preparation – familiar in countries such as Australia - involves the clinic or pre-operative nurses telephoning the patient 2-3 days before surgery, to give them important information. This also allows the nurses to check the patient's medical, surgical, ocular and social history.

Another alternative, still seen in many countries around the world, is to admit the patient for surgery the evening before. The checks can all be completed at this point.

Informed Consent and the Day of Surgery

Informed consent

As mentioned previously, Informed Consent is important. This section will now explain what it means and how it differs from other forms of consent.

During other forms of consent (which we do not advise), the patient signs a consent form without any information provided by the treating physician (surgeon). Alternatively, the basic act of the patient ‘turning up’ is considered as consent. While both these methods are still in practice in some parts of the world, they are not advised as they place both the patient and the healthcare team at risk.

The ‘gold standard’ in consent is a Written Informed Consent – which is now considered worldwide best clinical practice. This method requires the surgeon (and the anaesthetist in some countries, regarding anaesthetic consent) to provide a detailed outline of the proposed surgery to the patient and/or their guardian. Only after this is provided, and the patient has had the chance to ask questions, should the consent be signed. The consent process must take place in the presence of the surgeon or surgical assistant – who also signs in the presence of the patient and a witness.

It is recommended that each facility have in place a policy that outlines the procedure for obtaining Informed Consent. While these policies may vary around the world, there are some fundamental and universal standards which are commonly used. This includes the surgeon providing information on:

- diagnosis
- non-surgical and surgical treatment options and possible future treatment options and prognosis if no treatment is chosen
- reasons for recommending surgical treatment and expected outcomes
- statistics on rates of complications of treatment including fatality and infection rates
- cost to the patient for surgery
- potential on-going costs
- how the patient is to prepare for surgery
- post-operative expected outcomes.

This must take place by:

- The process being conducted by the surgeon or surgical assistant (who acts under the direction of the surgeon) as both will be present during the surgery.
- Providing the consent in a language understood by the patient or their carer.
- Signed by the Surgeon (or surgical assistant), patient and the witness;
 - note: variance occurs for children, persons with intellectual disabilities or other debilitating conditions preventing them from providing their own consent. In these instances the parent or next-of-kin is legally responsible for signing the consent.
- Signed by the patient (or parents/next-of-kin if the patient is under age or unable to do so);
 - note: for persons without a signature, a 'thumb print' can be used as proof of consent.
- The patient's signature is to be witnessed by another person of legal age and sound mind.

The consent form must contain:

- space to write the patient's full name
- space to write the surgeon's full name
- date of surgery
- type of proposed surgery (e.g. cataract surgery)
- surgical site (e.g. left or right eye)
- information on any prosthetics needed (e.g. an IOL)
- type of anaesthetic expected (e.g. general anaesthetic or local with sedation)
- details of legal responsibilities, issues and risks as outlined by the surgeon (this can be pre-printed on each form)
- space for the surgeon, patient and witness to sign and date.

This signed consent form is then prepared and presented on the day of surgery – though preferably before the day of surgery – and placed within the patient's chart as part of the patient's hospital records.

The consent form becomes part of the Surgical Safety Checking System and should be labelled, with the patient's full name, date of birth and hospital record number (WHO: Performance of Correct Procedure at Correct Body Site, 2007; World Alliance for Patient Safety, Implementation Manual Surgical Safety Checklist, 2008).

Informed consent copies: In some countries consent forms are placed onto 'carbon paper' which means that the form and signatures can be duplicated. A copy stays with the chart, while another can be given to the surgeon for their notes, and the last provided to the patient for their own record. While carbon paper may cost a little more to purchase and print-on, it is often worth it to reduce the staff's time to photocopy or write multiple copies. An alternative option is an electronic signature, for example, by using a touch computer on an iPad. This can then be emailed to all parties as part of the electronic medical record (EMR) system.

Explaining the procedure to the patient

When the day of surgery arrives, the patient presents to the facility. The reception staff are responsible for notifying the pre-operative nurse that the patient has arrived. They are also responsible for double-checking the patient identifiers on the paperwork, preparing the patient's chart, logging any data entries (i.e. ICD 10 coding into the system) and managing any billing (payment) issues that arise.

Payments for services: Every country and facility has a different payment system. Some require patients to pay part or all of the cost for surgery, while others have a national health system in place that covers some/all of the costs. Additionally, many countries have a medical insurance system whereby the patient pays into the system on a regular basis. Depending on their insurance policy this may reduce the amount they need to pay on arrival at the hospital.

Coding systems are also used so the Ministry (Department) of Health, insurance companies and the hospital, can calculate cost recoveries, payments, and health statistical data details. There may be international or national coding systems in place in each hospital too.

Regardless of the system, payments and billing can be very confusing. Generally, specialist medical receptionists and clinical coders can take care of these aspects of the patient's visit. There are special courses available to teach administrators about coding, administration/reception skills, payment and billing.

Once the patient has completed the admission process, the pre-operative nurse is then responsible for preparing the patient for surgery. The nurse should be aware that the patient may be experiencing anxiety and/or fear regarding the proposed procedure. Therefore it is important to:

- Explain the pre-operative process before commencing any procedure.
- Talk the patient through any procedure (i.e. betadine pre-wash) beforehand.
- Answer any of the patient's questions.
- Invite the carer (just one) to stay with the patient until they go into surgery.
- Try not to use any medical terms or jargon.

During this time, the patient is changed, and/or a gown is placed over their street clothes. Jewellery and other items are removed and the eye is prepped. Please see section 5 for further information on prepping.

This pre-operative period provides the nurse with an excellent opportunity to interact with the patient and carer. This should increase the patient's capacity and capability to comply with instructions and hopefully decrease their anxiety.

The nurse may need to provide the patient with information on:

- Surgery/procedures:
 - when vision will be restored

- pain and sensations during and after the surgery
- the need to keep still during the surgery
- effects of pre-operative eye drops
- what to do if they need to cough/sneeze during the procedure.
- Anaesthesia - the preparation required and recovery period of each type:
 - general anaesthesia (GA)
 - regional/local/sub-tenon's anaesthesia
 - topical anaesthesia.

Note: the use of pre-medications and sedation during the procedure should be discussed as required by the anaesthetist.

What will happen after surgery (post-operative care):

- post-operative eye patch covering and when to remove
- follow-up appointments
- what the patient can and cannot do when they return home

Patient privacy

Ideally, it is preferred that patients are provided with privacy during the pre-operative phase. This will reduce embarrassment when asking personal questions, and will provide greater opportunities for the nurse to interact with the patient. It also allows the patient to complete procedures without others feeling uncomfortable.

Sadly however, in some parts of the world, where hospitals and clinics have limited space, there is very little opportunity to provide every patient with a private area. If physical privacy (i.e. individual rooms) are not possible then try and be creative about how this can be provided, for example, erecting curtains, wall dividers, or cornering off a section of the room. Whatever can be provided will be better than nothing, and will give the patient the opportunity to ask private questions and answer any which are delicate or embarrassing.

Patient identification

Most hospitals will have developed a patient identification system with policies and/or procedures – based on recommendations from the WHO. A “Patient Identifier”, as discussed in section 1, is defined as having three approved pieces of information about the patient in order to help identify them during all stages of the hospital process. This is especially important in communities where there are similar sounding (or spelt) names.

Nurses and technicians should encourage patients and their families to be active participants in providing accurate information and answering identification questions. They also need to be comfortable with expressing concerns about safety and potential errors, and ask questions about the correctness of their care (World Alliance for Patient Safety, Implementation Manual Surgical Safety Checklist, 2008). For further information, please see section 1.

When there is an issue with the consent and identity checks

If for some reason there is an issue with the consent or patient identification (other than a typing error which can be corrected between the nurse and reception staff), then do not proceed with treatment until the assigned surgeon (or surgical assistant) reviews and corrects the issue. This means, no marking of the surgical site, no pre-operative eye drops and no anaesthetics until the matter is resolved. For example, a patient may insist that they are having surgery on their left eye, but the consent says right eye. Another example is when the consent and patient say ‘cataract’ but the surgical schedule suggests ‘vitrectomy’. In both cases – tell the surgeon.

STOPPING and CHECKING helps prevent medical error and harm to the patient. An additional way of stopping and checking is via routine use of a Safe Site Surgery (SSS) Checking System. Please see section 1 for further SSS details.

Marking the surgical site

Once patient identification and consent has been confirmed, the surgical site must be marked. There is great variance on how this is done and who is responsible for this. Every country is different. It is important to find out local policy before proceeding. Here are two methods used around the world for your consideration:

1. **Pre-operative nurse marks the surgical site** - The pre-operative nurse confirms the site (i.e. left eye) and marks that eye.
2. **Surgeon (or surgical assistant) marks the surgical site** - The surgeon (or surgical assistant) comes to the pre-operative area and re-confirms the site – they must go through the identification and consent check beforehand, and then mark the eye.

Note: regardless of the system used, as long as everyone in the hospital is following the same process, then errors will be reduced.

How to mark the site

Generally, the site needs to have a visible permanent mark that will not come off even when wet from a betadine wash. Here are some guiding principles:

- Ask the patient to point to the site (i.e. left eye). Confirm their physical check with their verbal confirmation and the consent form.
- Use a pen colour that is in contrast to the patient's skin colour, or use surgical-marking-tape (again in contrasting colours). If using tape, ensure it cannot come off when wet. For that reason, the indelible marking pen is advised.
- Use the same symbol facility wide. i.e. ‘x’ or ‘o’ or a dot or arrow.
- If surgery is bilateral, mark both sites/sides.
- If surgery requires grafting from elsewhere (i.e. behind the ear) then mark that area too.
- Place as close to the site as possible without intruding on the area, i.e. for cataract surgery of the left eye, place the mark about 1cm above the left eye brow.

Note: if the facility uses an adhesive sticky tape to mark the surgical site, ensure it is made of durable material than can be prepped over and will not come off when wet. Ideally though, it might be worth changing practice to the marking pen system.

Baseline observations

Preparation of the patient will also require a routine check of their blood pressure, pulse, and respiration rate and oxygen saturations. A physical review (observation) of the patient is also recommended and includes looking for open wounds, sticky (infected) eyes or other issues that could place the patient (or others) at risk. These baseline observations will assist in providing early warnings signs later on in the care process.

Additionally, other checks may be needed depending on the patient, such as:

- Blood sugar level of a patient who has diabetes.
- International Normalized Ratio (INR) level for patients on blood thinning medications – only if requested by their surgeon - before admission (and checking cessation of

thinning medication if ordered)

- Ocular surface marking for refractive intraocular lens surgery (the mark is used to line-up the refractive IOL) – though this is generally performed by the surgeon or a specifically trained technician.
- Confirmation that females who are undergoing an anaesthetic are not pregnant. This needs to be asked in a very delicate manner as there can be cultural or personal sensitivities around this. Always enquire in private. Notify the anaesthetist (or surgeon should no anaesthetist be available) if a patient is pregnant.

Recording temperature

- Temperature checks are required for all children and all adults scheduled for GA as their status can change quickly. Some facilities may routinely record the temperature for all other patients too.
- Document where the temperature has been taken from (i.e. the ear - tympanic measurement) so the same route can be used throughout the patient's stay, to ensure accuracy.
- Make sure team members routinely use the same measurement system too, i.e. Celsius or Fahrenheit.

Recording weight

- All children and all adults scheduled for a GA will require their weight to be recorded. Some facilities may also routinely record weight for all other patients too.
- Weight needs to be taken in Kilograms (kg) as this is now routinely accepted as the weight measurement for healthcare facilities around the world. The anaesthetist will need to calculate anaesthetic concentration based on the kg weight of the patient.

Standing orders - pre-operative medications

The nurse must be familiar with the standing orders for the particular surgeon (template available in Appendix B). This might include ophthalmic medications used in preparation for surgery, and those routinely used by that particular surgeon.

Prior to administering any medications (i.e. topical or oral), the nurse needs to be familiar with the common side effects. The nurse should also be aware of the emergency procedures and where equipment is kept, in the event of an anaphylactic reaction or major adverse reaction due to the administered medications.

Remember – once a patient has had their pupil dilated/constricted, their vision may become worse. They should be warned of this. Therefore, care is needed to ensure the patient is comfortable and safe at all times.

Documentation

Always record all baseline observations and the outcomes of other tests conducted. Additionally, always document the time each eye drop is given so the team can determine if the pre-operative drops are working – this will also help track how many have been given and how many more can be given.

Some medications may also need to be counter-signed by another nurse. Check policy as required.

Transferring and Positioning a Patient

Patients with poor vision, the elderly and those with a disability will need extra assistance and reassurance when being transferred to the OT (Kleinitz, 2011).

The nurse will need to:

- Speak clearly and calmly - keeping the instructions simple.
- Explain where they are taking them and why.
- Clearly explain the layout of the room and what the patient will need to do, e.g. lie flat on the bed with head supported on a pillow.

Guiding a vision impaired person is a special skill – it is recommended that staff complete a training course on guiding a vision impaired person, and on manual handling.

Comfortable positioning on the OT bed

Once the patient has been guided/assisted into the OT, they are to be placed on the operating bed (sometimes called a table, trolley or a gurney). Some patients may need extra support and time in order to get into a comfortable position before the procedure commences. Patients who have frail skin or damaged limbs may require extra support or padding to protect them, to assist in the prevention of pressure injuries and to ensure they are comfortable during the procedure.

Often a pillow is placed under the knees to help reduce the pressure from their back and prevent them from sliding down the bed. Their head is placed on to an extension pillow, often with an additional plastic or gel head-rest which helps prevent the head from moving around during surgery.

Some surgeons may request that the head is taped to the head-rest. This is common practice but should only be done with care and dignity. Always tell the patient that this will occur, and use a soft, surgical tape that will not cause injury. Ensure the head is firmly in place without being too tight or restrictive.

Body restraints – not recommended practice

While taping the head is common for eye surgery, the taping of other body parts is not. Some hospitals may routinely tape or tie patients to the bed via their wrists. While the premise behind this might be to stop the patient moving or putting their hands to their face, this actually causes them great distress and increases their anxiety, fear and panic (especially when placed under a hot drape). This can reduce their trust in the healthcare team. Moreover, holding someone in this manner could be interpreted as a violation of their rights.

Should a patient 'move' too much during a procedure, the OT team needs to engage with them and use specialist techniques to keep them still – without tying them down. If a patient moves then this indicates:

- they need more anaesthetic
- they should have been considered for a stronger, or general anaesthetic
- the surgeon/anaesthetist needs to gently ask them to keep still
- a member of the team should hold their hand under the drape. This does two things, 1). Keeps their arms down and stops them from moving, and 2). Provides reassurance to the patient, demonstrating they are not alone.

Post-operatively, the patient will need assistance with transfer from the operating bed. Special care must be taken when:

- the operated eye is covered and the patient has little or no vision in the other eye
- patients, who may have had sedation, may be drowsy, unsteady and/or unwell for several hours.

Giving this information as part of the pre-operative education will help reduce stress and anxiety and patients are more accepting of guidance and assistance (Marsden, 2006).

References

1. Duvall, B, S, Lens, A., & Werner, E, B. *Cataract and Glaucoma for Eye Care Paraprofessionals*. 1999. Slack Incorporated, New Jersey.
2. Frazier Byrne, S. *A-Scan Axial Eye Length Measurements: A Handbook for IOL Calculations*. 1995. Grove Park Publishers. North Carolina.
3. Kleinitz, P. *Disability Inclusive Practices in Eye Health - A Practical Guide*. 2011. Christian Blind Mission, Australia.
4. Marsden, J. *Ophthalmic Care*. 2006. Wiley. Chichester.
5. Pickett, K. *Overview of Ocular Surgery and Surgical Counselling*. 1999. Slack Incorporated, New Jersey.
6. Shaw, M, Lee, A., & Stollery, R. *Ophthalmic Nursing*, 4th Ed. 2010. Wiley-Blackwell. West Sussex.
7. Weinstock, F, J. *Management and Care of the Cataract Patient*. 1992. Boston. Blackwell Scientific Publications.
8. World Health Organization. *World Alliance for Patient Safety, Implementation Manual Surgical Safety Checklist 1st Edition*. 2008. Geneva.
9. World Health Organization. *Performance of Correct Procedure at Correct Body Site*. WHO Collaborating Centre for Patient Safety Solutions. 1, (4), 2007.

SECTION 4b

Care of the Surgical Patient – Anaesthetics, Recovery and Discharge.

Contributors: Sandra P Burnett and Heather Machin



Anaesthesia and recovery are very complex sub-specialty areas of health. The subjects cannot be covered in full, within this text, and competency as an anaesthetic practitioner requires a great deal of training. There is also a vast difference in the management of neonates, infants, children and adults during all phases of care which will not be covered in-depth in this text. Therefore, it is advised that this section be used as a guide only. Always consult the local anaesthetic director or anaesthetic council to ensure safe appropriate anaesthetic systems are in place in the facility.

Anaesthetics

The Anaesthetist

An anaesthetist (or an Anaesthesiologist in some countries) is a medical doctor (MD) who has specialist training to provide safe anaesthetic care to patients who require surgery, pain management and intensive care. Their care starts in the pre-operative assessment phase where they work with the surgeon and/or nursing staff to determine pre-operative instructions and selection of an appropriate anaesthetic. They are specialists who are trained in all aspects of medical care and have enhanced knowledge of underlying medical conditions which could cause harm/risk to a patient during surgery. They also understand how anaesthetic medications, gasses and drugs can impact a patient.

Anaesthetists preferably should be involved in all care requiring sedation or higher levels of anaesthetic provision. In some low resource locations, where there are few anaesthetists, hospitals have instead trained nurses with specific advanced anaesthetic skills (called nurse anaesthetists). These nurses work in each individual OT while an MD anaesthetist oversees all the Theatres. The anaesthetist can be called on by the nurse anaesthetist when needed. (Note: a nurse anaesthetist is different to an anaesthetic nurse who assists an anaesthetist.)

Defining Anaesthetic Team Members

MD Anaesthetist – A Medical Doctor with specialised anaesthetic training, overseeing all aspects of anaesthetic-surgical care.

Nurse Anaesthetist – A nurse (in some countries almost at the practitioner level) specifically trained to perform some functions of an anaesthetist, but always under MD anaesthetist supervision.

Anaesthetic Support Nurse – An OT nurse who has sub-specialised to provide support to visiting MD anaesthetists. They care for equipment and stock and perform other OT duties.

Anaesthetic Technician – A technician assists the visiting MD anaesthetist. They care for equipment and stock and perform other OT duties.

Anaesthesia care starts during the pre-admission phase when the consulting surgeon schedules a patient for surgery. Some systems have in place standing orders that require all patients with specific characteristics (i.e. pre-existing medical conditions) to be scheduled for a certain type of anaesthesia. This is mainly in place in facilities where anaesthesia support is readily available. In smaller, rural areas however, there may not be any options and in these cases the surgeon (and/or nurse) is the sole responsible provider of anaesthetic care. Different systems, in different locations, can be defined as:

Small, rural, surgeon or nurse only facilities

- no anaesthetic used routinely for some eye cases
- topical anaesthetic options
- local without sedation options
- no access to anaesthetic, emergency or intensivist support.

This means:

In a situation where there are no emergency medical support services available, the physician (and/or nurse) surgeon needs to ensure that they are not putting the patient at potential risk. This means they are ONLY providing surgery to patients who will have a good response to the available level of anaesthesia and are likely to respond well in an emergency. It is imperative that in these facilities a careful pre-operative assessment is conducted to determine patient suitability. For example, if the patient has abnormal blood pressure or poorly controlled diabetes, the surgeon may need to refer the patient to another medical doctor for medical management of those conditions. This patient may benefit from having their surgery performed at an urban centre where such advanced medical support services are available.

Urban/city centres

- topical anaesthetic options
- local without sedation option
- local with sedation option
- general anaesthetic (GA) option
- access to anaesthetic, emergency and intensivist support.

This means:

In such a situation, a wider variety of patients can be cared for, and the team can offer a suitable anaesthetic option. It also means, depending on the set-up of the facility, patients in higher-risk groups can receive surgical treatment because there is greater access to a variety of medication options and equipment, and there is access to back-up services and specialists.

Guidelines to help surgeon and anaesthetist decision making - introducing the ASA rating system

Selecting an appropriate anaesthetic type ultimately comes down to the pre-operative assessment by the surgeon, who assigns the patient's anaesthetic type, based on available guidelines. In facilities without such guidelines, surgeons will generally only contact an anaesthetist to seek help on a case-by-case basis.

There is a classification system developed by the American Society of Anesthesiologists (ASA) that can be used as a guideline. This system has become universally recognised by facilities, surgeons, anaesthetists and other healthcare workers when determining anaesthetic risk for each patient at each facility. The system is commonly referred to as the ASA.

How the ASA rating system works

In some parts of the world, a healthcare facility, such as a day-surgery facility or a general hospital, will determine what level of service they can provide in a safe and efficient manner. Factors will include their proximity to other specialists, intensive care services and the training level of their own clinical staff. They will also consider the infrastructure in their own facility and their ability to

Rating (ASA, 2014). It has 6 part scoring system, being:

ASA PS Classification	Definition	Examples, including, but not limited to:
ASA I	A normal healthy patient	Healthy, non-smoking, no or minimal alcohol use
ASA II	A patient with mild systemic disease	Mild diseases only without substantive functional limitations. Examples include (but not limited to): current smoker, pregnancy, obesity (30 < BM < 40), well controlled DM/HTN, mild lung disease
ASA III	A patient with severe systemic disease	Substantive functional limitations; One or more moderate to severe diseases. Examples include (but not limited to): poorly controlled DM or HTN, COPD, morbid obesity (BMI ≥40), active hepatitis, alcohol dependence or abuse, implanted pacemaker, moderate reduction of ejection fraction, ESRD undergoing regularly scheduled dialysis, premature infant PCA < 60 weeks, history (>3 months) of MI, CVA, TIA, or CAD/stents.
ASA IV	A patient with severe systemic disease that is a constant threat to life	Examples include (but not limited to): recent (< 3 months) MI, CVA, TIA, or CAD/stents, ongoing cardiac ischemia or severe valve dysfunction, severe reduction of ejection fraction, sepsis, DIC, ARD or ESRD not undergoing regularly scheduled dialysis
ASA V	A moribund patient who is not expected to survive without the operation	Examples include (but not limited to): ruptured abdominal/thoracic aneurysm, massive trauma, intracranial bleed with mass effect, ischemic bowel in the face of significant cardiac pathology or multiple organ/system dysfunction
ASA VI	A declared brain-dead patient whose organs/eyes/tissues are being removed for donation purposes	

Abbreviation Legend for ASA Rating

ASA PS—American Society of Anesthesiologist Physical Status

DM—diabetes mellitus

HTN—hypertension

COPD—chronic obstructive pulmonary disease

BMI—body mass index

ESRD—end-stage renal disease

PCA—post conceptual age

MI—myocardial infarction

CVA—cerebrovascular accident

TIA—transient ischemic attack

DIC—disseminated intravascular coagulation

ARD—acute respiratory disease

(ASA, 2014)

manage various patients requiring various anaesthetic types. This helps to ensure patients are safely matched to the correct facility. For example, a day surgery not attached to a full hospital may only be able to accept patients with an ASA Rating 1-2 or 1-3, while a general hospital may accept all patient types.

A surgeon, who is scheduling a patient in a facility, will generally know the available service level of that particular facility and will automatically schedule (match) suitable patients to suitable facilities. While there may be occasions when there is a mis-match, generally each facility will only admit patients they are equipped to care for. For example, while most ophthalmic surgery is performed in a day surgery setting, a surgeon will conduct surgery on a neonate or infant within a facility that is equipped to manage the anaesthetic care and any potential emergencies of the patient group. Therefore neonates or infants are taken to the general hospital for their surgery.

Once a surgeon or anaesthetist interviews the patient, they can determine which of the ASA categories the patient falls into, and what type of anaesthetic might suit them best. This is based on:

- age
- weight
- medical and surgical history
- degree of anxiety, fear or phobia
- ability to keep still during the procedure
- type of surgery scheduled
- anticipated length of surgery (i.e. 10 minutes vs. 2 hours)
- allergies and potential 'reaction'
- medical and surgical history
- post-surgery home care situation.

All these elements will determine the anaesthetic type, which may differ for each patient. The surgeon/anaesthetist will select the facility (i.e. day-surgery vs. general hospital) based on the proposed anaesthetic type and the patient's particular situation.

Differences in systems

In many low resource parts of the world, ophthalmic anaesthetic care is often lacking. This is in part due to a limitation of resources to support these services and/or available training. Therefore, ophthalmology surgery in day-surgery settings or solo eye hospitals have evolved without much interaction, revision or input from anaesthetists. To date, anaesthetics in eye care have received little recognition.

Anaesthetic support is one of the few areas of eye care which is vastly different between countries, with a huge practice divide between high and low resource locations – again, due to resources rather than a reflection on those working in each location.

Below is an overview of how each system differs within the context of the OT (note: general hospitals and minor procedure clinics are excluded from this example):

Eye hospitals and day surgeries in high resource locations:

- There is an anaesthetic medical director who is parallel to general or ophthalmological medical directors at board and policy level. These are available to provide case-by-case support and training needs as required.
- There may or may not be nurse anaesthetists employed under the direction of an anaesthetist.
- The anaesthetic staff support nurse specialists are involved in policy development.
- Quality, auditing and risk prevention is a high priority to prevent harm.
- Depending on the size of the facility, there may be specifically trained anaesthetic support nurses and anaesthetic technicians whose job it is to work in the sub-specialty areas of anaesthetics including pre-operative and recovery areas. They are responsible for all equipment and emergency checks, and support services to the anaesthetists.
- All hospital staff are trained in Basic Cardiopulmonary Resuscitation (Basic Life Support of BLS).
- A smaller team of advanced specialists (doctors and nurses) are trained in Advanced Cardiovascular Life Support (ACLS).
- They have in place an emergency system, such as: alarm bells, emergency protocols and medical emergency transfer plans.
- An anaesthetist or nurse anaesthetist is present for all surgical patients except those undergoing topical anaesthetic care.
- Other: most day surgeries in the high resource locations mandate that all patients (other than those requiring topical anaesthesia) must have an intravenous cannula (IVC) present even if they are not having sedation. This is because in the event that the patient has a reaction to the local anaesthetic, the anaesthetic team has immediate and direct access to a vein to administer emergency medications. If there is not an IVC in place then the team would lose valuable time while trying to put one into the patient in an emergency. Many hospitals accept this as a mandatory item and find ways to absorb the costs of the IVC for all surgical patients.

Eye hospitals and day surgeries in low resource locations

- Generally, anaesthetic medical directors or consultants are not widely (routinely) involved at board level and policy development. Nor are they routinely involved in day-to-day services in the eye care facility. Support is often sought from the general hospital on a case-by-case base only when a patient is scheduled for a general anaesthetic.
- Equipment is generally the responsibility of all staff rather than a specific group/person.
- Depending on the facility, all nurses are rotated through anaesthetics without a specific nurse or technician being responsible for the equipment and services.
- Anaesthetists are not routinely involved in patient care in the day surgery setting.
- Nurses may be responsible for the ophthalmic anaesthesia (country dependent).
- Patients do not routinely receive an IVC.
- In small eye facilities, patients requiring a GA are transferred to the general hospital.

While there are vast differences in the resources and training available to each facility, it is important to examine each facility and

consider ways to make the best of all situations within budgetary constraints. Those working with limited resources may, through their managers, consider promoting and implementing FREE system improvement options, such as:

- Finding out who the town’s leading anaesthetist is and develop a new relationship with them, and:
 - invite them to hold a voluntary position on the medical advisory board so they can share their knowledge. Particularly, ask them to:
 - comment and help edit policies such as: patient selection, pre-operative and post-operative care, administration of medications, emergency systems and many more
 - help (or recommend) local anaesthetists to put together some local training on anaesthetics or other training, such as CPR or specific issues such as Malignant Hyperthermia
 - review (audit) the anaesthetic services, equipment and machines and provide recommendations for improvement.
- Finding out where the local emergency and intensive care centres are – go and visit them. This will help provide an understanding of the importance of specialist care.
- Assigning a nurse/technician as responsible for anaesthetic services. They can help liaise between the anaesthetists and surgeons, stock team and the maintenance team, and conduct any anaesthetic system audits. In time, there may be an opportunity for them to learn more about anaesthetics and assist the anaesthetists during surgery.

Patient Fasting

As yet, the text has not addressed fasting. This is because within lower resource eye facility locations, adult patients are not always sedated and therefore they are not routinely required to fast.

Fasting is a process whereby the patient is asked to withhold oral food and fluid for a specified length of time prior to their proposed surgery start time. Anaesthetists require patients to have no food or fluid in their stomach at the time of surgery to prevent the patient from regurgitating their food - this could occlude the airway and lead to serious injury or death.

Therefore, patients who are required to fast need to be provided with clear instructions. Explaining why this is important may help compliance.

Fasting is different for each facility, type of anaesthetic, age and existing conditions. Therefore, systems and checks are needed to ensure the anaesthetist’s standing orders have been enforced. Here is a generalised example of the types of fasting that may be implemented (Note: this is an example only – not a rule). The ‘times’ are worked back from the time surgery is expected.

PATIENT TYPE	FOOD	FLUID
Adult	6 hours	2 hours
Adult with diabetes	6 hours	2 hours
Child	6 hours	2 hours
Infant breastfeeding	n/a	4 hours breast milk

WARNING: This is an example only. Please consult the anaesthetist for their fasting guidelines. Compliance with their guidelines is important.

Diabetic management and fasting

Every anaesthetist manages pre-surgical patient diabetes differently, though in general they may ask the patient to make some alterations to their usual (daily) management plan. This might confuse the patient, so explain why these changes are important. If they have been asked to withhold medication/insulin, it is important to explain to the patient that they need to monitor themselves for signs of hypoglycaemia. Anaesthetists may also place the diabetic patient first on the surgical list.

WARNING: Check the policy and/or the standing orders of the anaesthetist involved before making decisions and providing the patients with instructions or changes to their routine.

Peri-operative anaesthetic care

All ophthalmic surgical procedures require adequate anaesthesia. The choice of topical, local with sedation, local without sedation or general anaesthesia is determined by the surgeon and the anaesthetist. Considerations of the patient's age, overall health, and ability to cooperate also determines the type of anaesthesia to use. In addition, pre-existing general medical problems may make any type of anaesthesia risky, such as:

- asthma
- bronchitis
- diabetes
- heart disease - history of myocardial infarction, severe hypertension
- spinal problems - where the patient would find it intolerable to lie still even for a short period
- infection in the eye - postpone surgery
- chronic obesity.

Serious outcomes may be avoided with careful evaluation of the patient's medical management, and through adherence to proper treatment. (Schick, 2016)

Local anaesthesia should be carefully considered when caring for children or the mentally challenged, or when verbal communication with the patient is a problem.

The majority of ophthalmic surgeries performed on adults are provided under local or local with intravenous sedation. It is often the safest choice of anaesthesia because the patient does not lose consciousness. Local anaesthesia is also less expensive, uses less time and equipment and can be practised in remote locations. The patient can also recover more quickly.

While local anaesthesia is considered the safest option, there is always a risk of complication, so pre-operative assessment to prevent risk is essential.

Emergency preparedness

Routinely, all facilities should be prepared to manage the care of all medical emergencies. To do so, the facility requires:

- **Policy on medical emergency management** – which includes how to transfer a patient to the acute care unit or intensive care.
- **Policy on day-to-day emergency preparedness planning** - i.e. daily check of the emergency trolley and defibrillator. Maintenance of medication (i.e. checking expiration dates) and supplies.
- **Trained staff** - to assist with CPR, ACLS and supportive duties (i.e. nurses who are familiar with the emergency trolley and

assembly of resuscitation equipment, and administrators who know how to guide the emergency services during an emergency event).

Pre-operative patient preparation

In addition to the pre-operative nurse's check, the anaesthetic team is also responsible for confirming the patient's details as part of their SSS checking obligations - as a double-check measure. This includes:

- completing a medical, surgical and social history check
- completing the anaesthetic part of Sign-In prior to administering anaesthetics in the preparation area
- Participating in the Time-Out inside the OT.

Explaining the process to the patient

It is important to explain the anaesthetic process to the patient to help reduce their anxiety and increase their cooperation (Schick, 2016). This may include explaining that:

- Their non-operative eye may be taped closed.
- Their head may be secured (taped) to the bed-head.
- Their face will be covered by a sterile drape after the eye is prepped. Explain to them that they should not touch it.
- They need to keep still, and remain quiet during the operation, with their hands down by their side.
- Someone may hold their hand and they are to squeeze it if they are experiencing discomfort.
- They may have an IVC placed into a vein (most likely) on their arm or hand.
- They may feel cold air blowing, under the drape, on to their face or up their nose via prongs - this is the oxygen.
- They may feel irrigation fluid trickle under the drape, down their ear and neck.
- They may feel items placed/resting gently on their upper-chest.
- They may see light.
- They may hear conversations, music or beeping machines.
- The blood pressure cuff may inflate on their arm.
- The pulse oximeter probe may be attached to their finger.

Transfer to the OT/anaesthetic bay

When the patient is ready for transfer, escort them to the OT and assist them onto the surgery table (bed/trolley/gurneys) and:

- inform them of any steps up or down that they need to navigate
- hold their hand and give support
- ask them to lie on their back on the operating table, with hands at their sides, legs extended and head straight. A head ring may be used to support the head during surgery
 - maintain the patient's dignity by covering them with a light lint-free blanket if available (this is also for warmth as the OT can often be cold).

Patient positioning

Once positioned comfortably, with a pillow under their knees and head in the optimal position for the surgeon to access the surgical site, the anaesthetic team can continue to prepare the patient. This includes:

- Providing reassurance – answer any questions, ensure they

- feel safe and comfortable.
- Attaching the EKG (ECG) leads, pulse oximeter and non-invasive blood pressure cuff to monitor the patient's vital signs.
- Attaching any oxygen tubing via nasal prongs or airflow systems.
- Erecting any 'tent' elevation systems used to keep the drape off the patient and help create ventilation under the drape. A skilled scrub team can place the drape over the tent in a sterile manner.
- Preparing and administering any sedation and fluids via the IVC.
- Participating in the SSS Sign-In and Time-Out phases.
- Commencing anaesthesia (i.e. induction for a general anaesthetic. This will be explained shortly).

During and after the surgery

During the surgery

The anaesthetic team:

- May hold the patient's hand throughout the operation (under the drape without contaminating the sterile field) to help alleviate any identified anxiety and/or to allow the patient to communicate any distress. This should be under the drape without contaminating the sterile field.
- Complete paperwork and address immediate needs of the patient or surgical team.

Note: it is recommended that for all GA patients and at-risk patients under sedation, that a member of the anaesthetic team remains present for the duration of the surgery.

After the surgery

The anaesthetic team must:

- Listen to any post-operative instructions from the surgical team so that they can hand over the instructions to the recovery team and/or administer any medications immediately (i.e. some surgeons may require retinal patients to receive IV Diamox from the anaesthetist).
- Wait until the drapes are removed.
- For non-general anaesthetic patients:
 - once the patient's status is stable, remove observation cardiac monitoring wires and oxygen tubes. This can occur while the scrub team are placing the eye-pad or ointment over the surgical site
 - prepare the patient for transfer to the recovery area either via the bed. if they have received sedation. or by being escorted if they have not received sedation,
- Transfer the patient to recovery.
- For a patient receiving a general anaesthetic:
 - complete the anaesthetic reversal process
 - ensure all mobile oxygen and observation equipment are in place until the patient reaches the recovery area
 - ensure the patient remains on the bed until they are recovered. Depending on the facility they may stay on the OT bed or be transferred to a movable bed – while their airway is maintained.

Before bringing the next patient into the OT, the anaesthetic team must:

- tidy and clean their area
- re-stock

- for GA cases, they must re-set their machine and check it is working.

Local Anaesthetic

Local anaesthetic in eye care means several things:

- Topical** - where anaesthetic agents are placed onto the surgical area for local absorption.
- Local injection for oculoplastic surgery** - involves the administration of anaesthetic agents in the tissue immediately surrounding the proposed surgical site.
- Local injection for intraocular surgery (i.e. block)** - This is where anaesthetic agents are administered around the eye - within the orbit.
- Local Intracameral** - Anaesthetic agents are administered into the anterior chamber of the eye.

Topical anaesthesia

In ophthalmology, 'topical' generally means anaesthetic numbing agents are dropped onto the surface of the eye where they are locally absorbed and cause short term numbing of the ocular surface. This type of anaesthesia is often used in the minor procedure rooms and clinics to allow for examination of the eye and/or removal of a superficial foreign body.

In many parts of the world some cataract surgery is also conducted using a topical technique however it is not a widespread practice despite the beneficial rapid onset of anaesthesia. It requires the patient to be extremely cooperative and maintain a fixed gaze position. It also means the procedure must be completed quickly. Oxybuprocaine Hydrochloride (BNX), is an example of a common anaesthetic topical eye drop used pre-operatively for temporary surface numbing (use as directed by the surgeon/anaesthetist/standing orders).

Local anaesthesia for oculoplastic procedures

For surgery not involving the actual eye, such as an eyelid repair, the anaesthetic agent is injected into the tissue where the surgeon needs to work. This is called infiltration.

Local anaesthesia for intraocular procedures – known as a Block

Blocks are designed to temporarily immobilise the eye (i.e. stop it from moving) long enough for the surgeon to perform the surgery. There are two sharp needle methods available called retrobulbar and peribulbar injections. Over the years, trends have started to move towards a newer non-sharp needle technique called a sub-tenon's injection.

Around the world there is variance on who performs these procedures, such as the ophthalmologist, anaesthetist or a specifically trained nurse. In all instances, the person performing these procedures needs to be highly competent and knowledgeable of the anatomy of the eye and the conical orbital cavity, the anaesthetic agents they will be using, and potential harm that can be caused through incorrect administration. (Simonson, 1990)

WARNING: sharp-needle methods can cause serious temporary and permanent damage to a person's vision. Never attempt to conduct a Block without the necessary training.

Retrobulbar injection (rarely used these days):

- Anaesthetic is delivered into the muscle cone located behind the globe. It paralyses the recti and oblique muscles. It

- begins to take effect after 3-10 minutes.
- The eye may be massaged to facilitate diffusion of the drug into adjacent tissue and helps lower the intra-ocular pressure.
- Patient may receive 1-2 injections. The injection is traditionally given with a 23-25 gauge, 31mm long needle and 5-10ml syringe of anaesthetic.

WARNING: The main risk associated with this technique is damage to a blood vessel with the needle tip causing a retrobulbar haemorrhage. There is also risk of: perforation of the eyeball with a high risk of loss of vision; damage to the optic nerve again with loss of vision; and damage to nerves and muscles resulting in squint and double vision.

Peribulbar injection

- The anaesthetic is delivered into the orbital space. Injections are given into the inferior-lateral orbit with a 23, 25, 27 or 30 gauge, 25mm long needle on a 5-10ml syringe, or extension tubing may be used.
- It takes 5-20 minutes to work.

While safer than retrobulbar anaesthesia, there is still the risk of similar complications occurring, and a sharp needle is still involved. It is an easily usable technique in remote locations, requiring only readily available equipment (i.e. a syringe and needle).

Sub-tenon's infiltration

- Requires a sterile sub-tenon's kit with Baraquar speculum, Moorfield forceps, Westcott scissors, and a blunt cannula, or plastic jelco cannula, and a sterile surgical approach using sterile gloves and drapes.
- Whilst thought by many to be safer than sharp needle techniques, there are still reported cases with all the above complications (loss of vision, perforation of sclera, retrobulbar haemorrhage, squint and double vision). It may also be given as a supplement when either the retrobulbar or peribulbar injection needs topping up.

(Guise, 2012)

Common items needed to administer anaesthetic (e.g. a Block):

- assorted syringes: 3 ml, 6 ml and 12 ml
- assorted needles: 21, 23, 25, 26, 27 and 30 gauge
- gauze swabs
- assorted eye drops: antibiotic, mydriatic, miotic, topical anaesthetic
- gallipots containing Povidone Iodine solution which is used on the face and within the conjunctival sac
- local anaesthetic agents, e.g. Lignocaine 2%, Lignocaine & Adrenaline 1:200,000 and Hyaluronidase, and if available, Bupivacaine, or Ropivacaine.

Before commencing a Block:

- lie the patient down in a position that works best
- ask the patient to position their head so they are looking towards the ceiling
- ensure adequate lighting
- ensure the patient, trolley or self cannot be 'bumped' and 'knocked' while conducting the procedure
- open up items onto a sterile set-up area
- perform Time-Out
- wash hands

- don sterile gloves
- clean the area of skin around the eye, including the eyebrows, paying particular attention to the eyelashes, with an antiseptic skin preparation, e.g. Povidone Iodine solution. Also ensure some Povidone Iodine enters the conjunctival sac as this will help prevent endophthalmitis.

Local intracameral

An intracameral injection administers anaesthetics into the anterior chamber of the eye. This is performed during the surgery, by the surgeon, under sterile conditions. It is used with topical anaesthesia or to top up an inadequate block.

This same method (route) can also be used for antibiotic injection at the end of the surgery.

Mechanism of anaesthetic action

- Local anaesthetics are used because they provide reversible loss of conduction along nerves - resulting in numbness; lack of muscle movement of the eye and eyelid - and may spread to the optic nerve - causing reversible loss of vision.
- Adrenaline is added to some solutions to slow down absorption from the site of action, and prolongs the duration of action. It is also used to vasoconstrict blood vessels to minimise bleeding during some operations - particularly eyelid surgery and tear duct surgery.
 - It should be avoided for retrobulbar and peribulbar blocks due to the risk of retinal artery spasm and thrombosis which can result in loss of vision in the eye.
- Hyaluronidase is sometimes used to enhance tissue permeability, and spread the local anaesthetic solution. It will also increase the clearing of the local anaesthetic, shortening its duration of action.

(Bartlett, Jaanus & Blaho, 2001; Treitel, 1965)

Common ophthalmic anaesthetic agents (used for Blocks)

WARNING: The list below describes some common agents. It is beyond the scope of this text to provide full product information and has been provided as a guide only. All medications have side effects and different patients require different types and doses. Please refer to current product information prior to useage, and always check with the anaesthetist and surgeon prior to preparation and administration.

Bupivacaine, Lignocaine, Levobupivacaine and Ropivacaine

These agents are common local anaesthetics used in ophthalmology. They block the generation and conduction of nerve impulses.

Bupivacaine Hydrochloride

- 3 to 4 times more potent than Lidocaine and has a longer duration of anaesthesia (around 8 hrs) (Lamb & Bataoel, 2008)
- options: 0.25% or 0.5% injection
- bupivacaine 0.5% injection has an onset of action within 15 to 20 minutes, duration of 8 to 12 hours. It produces a complete motor block
- bupivacaine is frequently used in combination with lidocaine 2%, adrenaline/epinephrine and hyaluronidase
- maximum adult dose should be 2mg/kg. Dosage should be reduced for the elderly or debilitated patient
- adverse reactions:

- CNS - agitation, anxiety, tingling around mouth, tremor, seizures
- CVS - low blood pressure, bradycardia, arrhythmias, cardiac arrest
- respiratory depression/arrest

- deterioration in level of consciousness
- hypotension.

These effects may culminate in cardiac arrest.

Management of local anaesthetic toxicity

Local Anaesthetic (LA) toxicity is very unlikely with the doses of local anaesthetic used for eye blocks.

Immediate management includes:

- stop injection
- get help
- Maintain airway, and intubate if necessary
- give 100% oxygen
- ventilate
- get IV access
- monitor BP & pulse
- Notify the anaesthetist, who may treat seizures with Midazolam (benzodiazepine), Thiopentone or Propofol in small doses, if necessary (case dependent)
- if in cardiac arrest, start CPR, and follow the cardiac arrest protocol
 - initiate ACLS (if trained)
 - Seek further help and/or follow the directions of the anaesthetist or attending trained ACLS professional.

Oculocardiac reflex

Although rare, a well-documented effect of injections or other manipulations around the eye include sudden and severe bradycardia (slowing of the pulse). This can be caused by pulling, by the surgeon, on eye muscles and/or direct pressure on the globe (massage). Note: this can also end in cardiac arrest.

Retrobulbar haemorrhage

The eye becomes very hard and proptosed. Pressure must be applied immediately and the operation postponed. Treatment is aimed at lowering ocular pressure and protecting the optic nerve. Emergent lateral canthotomy may be performed to relieve orbital pressure. Oral Diamox 500mg or intravenous Mannitol may be used to lower the ocular pressure.

Trauma to the globe and optic nerve

The effect may not be immediate. The surgeon will identify a yellow fundal reflex and post-operatively the visual acuity will be reduced. The eye will become soft. This can lead to a retinal detachment.

Dural spread of local anaesthetic

The patient will become non-responsive, lose consciousness, may become hypotensive and bradycardic (low BP and slow pulse). They may need help with breathing. Monitor BP and pulse rate, and support with drugs such as Aramine, Ephedrine, Atropine or Glycopyrolate as required. The brain stem anaesthesia usually lasts for about 20 minutes.

WARNING: If there is any cause for concern, it must be referred to a senior, qualified member of staff immediately. Always be alert for any change in conscious level, and the patient complaining of 'not feeling well' or showing signs of twitching.

Lignocaine hydrochloride

- options: 0.5%, 1%, 1.5 %, or 2% solution (Lamb & Bataoel, 2008)
- contra-indicated for patients allergic to lignocaine
- lignocaine has a rapid onset of action with a duration of 45 minutes or more with adrenaline
- maximum adult dosage 3mg/kg with plain lignocaine, or 7mg/kg with adrenaline/epinephrine
- mixes of lignocaine and bupivacaine are often used to provide a longer duration of action
- adverse reactions similar to Bupivacaine.

Levobupivacaine

- is less cardiotoxic than Bupivacaine.

Ropivacaine

- has a similar duration of action to Bupivacaine, but is less cardiotoxic. Maximum safe dose is 3mg/kg.

Deciding how much of the drug to use

The concentration is based on several key factors, such as the patient's weight in kilograms (kg), the proposed duration of the surgery and any allergies or other known health issues of relevance. This is not usually a problem with eye surgery due to the small volumes used.

Signs and symptoms of injection complications

From time to time a patient may have a reaction to an administered anaesthetic. It is important that as soon as a block has been administered to a patient, that they are never left alone in a room without a medical staff member present. This staff member must be familiar with the signs and symptoms of adverse reactions. (Schick, 2016)

Toxic signs can arise because of a relative overdose for that patient. Accidental intravascular injection or very rarely, intradural injection can occur. Signs and symptoms are outlined next.

Central nervous system signs and symptoms

- dizziness
- drowsiness
- mental confusion
- tongue numbness
- twitching and convulsions
- respiratory distress, apnoea (breathing stops)
- loss of consciousness

These effects may culminate in coma.

Cardiovascular system signs and symptoms

- mental confusion
- increased pulse rate
- pallor
- sweating

Sedation

Sedation is used to reduce anxiety and to make the person drowsy, preferably without loss of consciousness and without putting the person under a full general anaesthetic. While sedated, the person should be responsible for their own breathing, but may be apnoeic (not breathing) for a period of time. They should be closely monitored, and oxygen given, during this time. They may be able to talk and can manage instructions when asked. After the surgery, the person can generally recover quickly. This makes sedation ideal for day-surgery patients.

Many people refer to this form of local anaesthetic as Twilight Sedation, which refers to the period when a person wakes up each morning – when their sleep and dream phase ends and their waking life comes back into their consciousness. This means that they are aware but are not fully aware of what is happening during that period.

Anaesthetists will administer, through the IVC, sedatives and other agents to help reduce pain and help the patient to forget. Therefore, sedatives make an ideal agent prior to administering any local anaesthetic.

General Anaesthetic (GA)

General Anaesthesia (GA) refers to a state of controlled unconsciousness (Press, 2015). The patient is taken to a level of sedation where there is no sensation, memory or movement. An airway is inserted, either a laryngeal mask, or the patient is intubated by a tube that goes through the larynx. Breathing tubing is connected to the anaesthetic machine, and the patient either breathes spontaneously or is connected to a ventilator. Anaesthetic gases may be administered to keep the patient unconscious, and/or anaesthetic drugs can be given through the IV line.

While most ophthalmic operations are performed under local, some patients require a GA. In particular: paediatrics, lengthy surgeries, mentally challenged patients, and/or a patient unable to lie flat or still.

GA consists of five distinct phases:

1. pre-medication
2. induction
3. maintenance
4. reversal
5. recovery.

Important to note

1. All anaesthetic machines and equipment must be checked and confirmed as safe before each patient enters the OT.
2. The emergency crash trolley needs to be checked each day – prior to a GA commencing.
3. All GA patients need to be fasted.
4. All GA patients need an IVC which is patent (working) and easily accessible to the anaesthetist.
5. All GA patients need to be attached to monitoring equipment with regular observation checks.
6. The anaesthetic team must complete/participate in the Sign-Out and Time Out section of the SSS Check System.
7. A member of the anaesthetic team (most likely the anaesthetist) must remain with the GA patient for the duration of their time in the OT.
8. The anaesthetic team advises when the scrub surgical team may prep the patient.

9. The surgical team must comply with concerns raised by the anaesthetic team throughout the surgery and help to provide airway access if needed in an emergency.
10. In the event of an emergency, the entire OT team is advised to follow directions from the anaesthetist: **Patent airway and anaesthetic issues come before all else – without exception.**
11. During Induction and Reversal, the anaesthetist will require assistance from a trained anaesthetic support nurse.

Phase 1: Pre-medication

The goal of pre-medication is to help calm and relax the patient. A variety of medications are used to relieve anxiety, encourage amnesia and to dry up oral secretions.

Prior to the administration of any medications, all monitoring devices are attached to the patient (i.e. the pulse oximeter, blood pressure and ECG). The patient status is monitored throughout the anaesthetic.

Pre-medications are rarely accompanied by anticholinergic agents, such as Atropine Sulfate, to reduce salivary and bronchial secretions. Pre-medication may offer some level of sedation and amnesia.

Ketamine is another sedation that might be used with children or the challenged patient. This may be given intramuscularly.

Phase 2: Induction

Induction is the process of starting to 'place the patient into an unconscious state'. To start this off, the anaesthetist will use either of the following two methods to commence the process:

1. intravenous
2. inhalation (respiratory/breathing in).

Intravenous routes are ideal as they are rapid in onset and more controlled. The most commonly used intravenous induction agent is Propofol; it has a very rapid action and induces sleep in about 40 seconds.

Suxamethonium, a short-acting muscle relaxant, may then be given, or a longer acting muscle relaxant, to facilitate intubation with an endotracheal tube. Suxamethonium immobilises the laryngeal muscles within 30 seconds and may paralyse the patient for up to 10 mins (much longer if they have a cholinesterase enzyme deficiency). During this time, the patient is completely paralysed. Soon after injecting Suxamethonium, some patients may experience muscle twitching. This may lead to muscle pains for a few days post-operatively but patients can be reassured that it will subside.

The Inhalation route is more frequently used first off with children because of their fear of needles. Inhalation induction is through breathing. A mask is placed over the mouth and nose and the patient is encouraged to take nice deep breaths. As the mask is connected to the anaesthetic machine the patient slowly falls asleep as the volatile anaesthetic agent (such as Sevoflurane) is given. Once the patient is asleep, an airway is inserted and is connected to the anaesthetic machine.

Function of the anaesthetic machine – making people sleepy

The anaesthetic machine uses volatile agents which are deemed safe for human use within this controlled and managed context. (Eger, 2004) Currently common gases used are:

- Halothane

- Enflurane
- Isoflurane
- Sevoflurane
- Nitrous oxide.

Sevoflurane is currently the more commonly used gas (agent) because it is less irritating to the airway, and has fairly rapid onset and offset. It has a strong odour which may be concealed with scented masks.

Selection tends to vary around the world due to price and accessibility in each location. Regardless of the gas agents used, the anaesthetic team must be proficient in understanding their actions inside the human body, and with airway management.

WARNING: When using anaesthetic gas agents it is important to make sure the machine has been checked for leaks and that the OT has good airflow. Additionally the anaesthetic machine needs to have a filter system called a scavenger system to help remove residual toxic fumes from within the room.

Without these systems in place, there is a likelihood the vapours would escape into the OT, and place the staff at risk of breathing it in. Think about this carefully; these gases are designed to put people to sleep. What would happen if the staff inhaled these fumes? This is not safe.

Safety with cylinders: Remember that gas agents for anaesthetic machines are supplied in cylinders. All cylinders need to be stored in an 'upright' position. They also need to be anchored to the machine, (a purpose-built stand or the wall) so there is no chance of them falling over. Cylinders are connected to the anaesthetic machine by a pin system, to prevent incorrect cylinders being attached to the machine, for patient safety. They must never be forcefully attached to the machine.

Oxygen use during a GA

Oxygen is given to maintain a safe level of oxygen in the blood and vital organs like the brain. 100% oxygen is given prior to induction, to replace nitrogen in the lungs with oxygen. This increases the safety if there are any airway problems at the start of the anaesthetic. During anaesthesia, oxygen levels are decreased - often 30-60%. Oxygen saturation should be above 94% on a pulse oximeter.

Intubation – and understanding the airway

The airway is maintained under anaesthesia by either a laryngeal mask airway or by intubating the airway.

The laryngeal mask airway is a supra-glottic device. It sits above the larynx forming a seal which is not airtight. It reduces the risk of abdominal distension with bag mask ventilation, but does not eliminate the risk of aspiration of acid stomach contents.

Intubation is the process of passing a tube through the vocal cords of the larynx (voice box) and then into the trachea (also known as the windpipe). (Polansky, 1996) A metal instrument (laryngoscope) is used to ensure the vocal cords can be visualised, so that the tube can be passed between the vocal cords. The tube is then connected to the anaesthetic machine, and the patient may then breathe spontaneously or be ventilated by a machine.

Tubes these days are made of a flexible plastic material. They come in a variety of sizes to suit neonates all the way up to larger adults. The anaesthetic team matches every patient to the size they have available to ensure the tube can be positioned correctly and comfortably and allow appropriate volumes of agents to pass through.

There are many types of tubes - most are passed through the mouth but some are passed through the nose (nasal-tracheal tubes). Either way, their aim is to maintain an open airway and allow the anaesthetic agents to enter the lungs.

The balloon on the endotracheal tube, (and the laryngeal mask airway), is inflated by a syringe containing room air until there is no air leak when the patient is ventilated with positive pressure. This creates a soft anchor against the mucosal wall and prevents oral secretions from entering the lungs. Excessive pressure can lead to damage to the tracheal lining, and later tracheal stenosis, or tracheal narrowing, especially for very long operations, and when N2O is used.

Once the airway tube is in place, it is connected to the machine's delivery tubes (circuit). Anaesthetists will use a soft medical adhesive tape to secure the tube to the patient's face (depending on the access site needed by the surgeon) and they may also tape the machine's extended tubes to the patient's blanket to prevent it falling and tugging on the airway.

Once the anaesthetist is satisfied that they have a good airway and good control (care and management) of the patient's breathing, the surgical team may commence preparation and draping.

Note: the balloon anchor will have to be deflated by the anaesthetist during Reversal (Phase 4) so that the tube can be removed once the patient is ready to wake up.

Phase 3: Maintenance

Throughout the surgery, the anaesthetist must remain in the OT. They may continue to administer a variety of drugs and gas agents to keep the patient unconscious and maintain physiological stability. They will check and record vital signs routinely so that they can monitor significant fluctuations (changes/trends up or down) in the patient's status and may adjust gases, medication or airway positioning as needed.

Phase 4: Reversal

The reversal phase, also known as anaesthetic emergence, is timed with the completion of the surgical procedure, and the patient is woken up. Ideally, a surgeon will inform the anaesthetist that the surgery is almost finished. This gives the anaesthetist time to call in their anaesthetic support nurse and prepare items they need for reversal and transfer to the recovery unit. Some hospitals with phones in their OT will also use this time to telephone the recovery unit staff – thus providing the recovery staff with sufficient notice to prepare for the arrival of their next patient.

Generally, the anaesthetist will standby while the drapes are removed, the surgical site is washed and dressings are applied (some may even assist with this). Thereafter the surgical team are required to remove all their equipment and trolleys from the immediate patient area as quickly as possible –allowing the anaesthetic team full access to the patient.

The anaesthetist will commence reversal by weaning (slowly removing) the patient from the anaesthetic gases, and reversing the action of any longer acting muscle relaxant, if used with Neostigmine and Atropine or Glycopyrolate. Depending on the patient and the gas agents used, this process can be very quick while at other times it can be very slow. Patients may also be slow to breathe after large or recent doses of opiates. The members of the team need patience during this time and ensure they are all on hand to assist the anaesthetist as needed. The safe reversal of the anaesthetic for this patient is the priority of the whole team before setting up for the next patient. The endotracheal tube (or nasotracheal tube) should always be removed in the OT, with suction, oxygen,

and anaesthetic help. Drugs, laryngoscope and tubes should be available for re-intubation if necessary.

Other important facts about GA

- Atropine may be used to reduce oral secretions (rarely).
- Narcotics and other pain relieving agents such as paracetamol and NSAIDs (Ibuprofen) may be delivered to maintain patient comfort in the recovery room.
- If required, the patient is moved from a stationary OT table to a mobile bed – with airways maintained - and then transferred to the recovery room.
- Positioning of a patient's head, and jaw thrust, is really important for ensuring an open airway. The positioning – or head tilt, differs depending on the person's age/size.

Removing the ETT

As outlined earlier, the balloon must be deflated first and foremost. Thereafter, once the patient has started to regain control of their own body – i.e. they start waking up and breathing for themselves, the airway tube can be removed. (Schick, 2016) Exactly where and when this occurs, varies around the world, and also varies depending on the size of the facility, policy of the facility and personal preference of the anaesthetist. Here are some methods routinely seen:

ETT removed in the OT:

- Anaesthetist removes the airway tube, and places the oxygen mask over the patient's mouth and nose, and transfers the patient to the recovery area where there are trained recovery staff to complete the post-anaesthetic phase of care. The patient's O₂ Saturation should be checked with a pulse oximeter. (Note: patients can take an extended period to wake up. If a patient is recovered in the OT it can delay the OT start time for the next patient. This time needs to be factored into the daily schedule.)

Oral airway tube removed in the recovery area:

- Patient may be transferred to the recovery area with a laryngeal mask, or guedel airway, in position.
- Patient removes their own airway when they wake up, either voluntarily or via instruction, from the recovery nurse. The oxygen mask is then placed over the patient's face and nose. This method, which is widely used around the world, can only occur if the recovery team are proficient at safe airway management.

Regardless of when the tube is removed, there are some key instructions for the post-operative care of the GA patient:

- Always ensure the patient's head is positioned (tilted) appropriately for the age/size of the patient – consider the oxygen saturation levels.
- Never remove the airway before the patient has started to rouse as they may not be able to breathe for themselves.
- Never forcibly remove an airway tube as this might damage the patient's teeth.
- If the patient is biting down, just wait until they relax their grip.
- Often, the nurse can say to the rousing patient "open your mouth and push it (oral airway) out" or "push your tongue forward". Once the patient pushes the tube out the recovery nurse can gently assist with the removal.
- If the airway is removed and the patient needs further airway assistance, jaw support and additional devices such as a

nasal airway or a Guedels airway can be inserted temporarily. In either instance, competence on when and how to insert these devices is necessary. Size varies with the age and size of the patient too.

A CLEAR AIRWAY MUST BE MAINTAINED AT ALL TIMES.

Transfer to recovery

Two members of the OT team must transfer the patient to the recovery area. One member should be the anaesthetist. The patient needs to be kept stable, i.e. breathing on their own, during this transfer. If the OT and recovery area are far apart, the anaesthetist will need to make sure the patient is stable during transit. They may use mobile oxygen units and additional mobile monitoring devices to support the patient during the transfer.

The anaesthetist may routinely position themselves at the head of the bed so they can be close to the patient's airway during the transfer - in case they need to re-position the patient's head.

On entry to the recovery unit, a handover is provided by the OT/ anaesthetic representative to the recovery team. The patient is then connected to the oxygen and monitoring devices in the recovery room. Observations in the recovery room of pulse rate BP, respiratory rate and oxygen saturation should be within 20% of the preoperative observations.

Cleaning-up and preparing for the next patient

- Once the patient has been transferred to the recovery unit, the anaesthetic team is to return to the OT and clean the machine, clear away any rubbish and re-stock. They must then set up for the next patient and check the circuit is working.
- Any spills of body fluid or blood should be removed and all surfaces cleaned with a hospital disinfectant.
- The anaesthesia machine and the OT should receive a full clean and re-stock at the end of day.

The circuit

A circuit is a special tubing set that is attached at one end to the anaesthetic machine, and to the patient's airway (or induction mask) at the other. It is also accompanied by a rugby ball shaped "balloon" that can be inflated by the machine and deflated by the anaesthetist's hand when the anaesthetist needs to manually provide a breath to the patient (i.e. they push the agents through the tubing and into the patient's lungs). The circuit is, in essence, the delivery system for the gas agents and breathing.

There are lots of different types of circuit equipment on the market and there are different sizes for infants and adults. In a high resource location, a filter is used at the patient end of the circuit to prevent transferring infection between patients. This is changed between each case.

In low resource locations however, where there are limited circuit sets, the OT tend to re-use the same circuit for all patients without changing between cases. While it is acknowledged that this is occurring, wherever extra funding is available, the purchase of more sets (even if they are reusable) is essential. This way, at least, each patient can have a clean circuit each time. This is an important part of reducing the spread of potential respiratory infections from one person directly to the next person.

There are several texts and courses available, throughout the world, that provides information on the training of nurses and technicians on GA anaesthetic management including equipment and machine care and cleaning.

Caring for special categories of patients

This section draws attention to some specific categories of patients that need special care. (Schick, 2016) This is only an introduction and is not an exhaustive list. It is advisable to undertake additional studies to learn more about caring for the needs of these patients. This section will discuss the management of:

- paediatric patients who are given a GA
- sickle cell disease
- infectious diseases
- patients who are overweight
- patients with an intellectual or physical disability
- patients with language and communication difficulties.

GA for paediatric patients

There are significant physiological differences that need to be taken into consideration when managing infants and children within the healthcare setting. The anaesthetic team will need to understand the physiological differences at each developmental stage in a child's life. They also need to examine the patient before determining what equipment and agent concentrations are needed. This combined knowledge will help them to match equipment and drug/gas concentration rates to the size (weight) of the child. If this is not done then the child may be at significant risk of overdose or sub-optimal anaesthesia.

Reducing fear and anxiety in children

Hospitalised children experience fear and anxiety for many reasons. They may feel the staff are intimidating, there are strange rooms with different sounds and smells, and their routine has changed.

An anxious or frightened child can, in turn, be difficult to manage. Therefore, every effort should be made to keep children as happy and calm as possible. Many hospitals implement several initiatives to enhance their environment when caring for children. Here are some examples found around the world:

- The child may be accompanied into the OT by their parent/ carer, who stays with them until they go to sleep.
- The area is painted and decorated in calming colours.
- There are special children's areas decorated with funny and friendly children's characters (Photo 4b.1 and 4b.2).
- Children are admitted and allowed to interact (play) with other children before surgery (assuming there are no compromising infection issues to prevent them from doing so).
- Hospitals may have colouring books and crayons ready to keep them entertained.
- Staff wear bright and fun coloured scrub clothes.
- Staff help to encourage (safe) play – they can sing with the children or join in the colouring activities.
- Staff use non-threatening verbal and body language.
- Staff tell the child what is happening. They do so at a level a child would understand. This ensures that the child is not shocked or frightened when they are transferred to another room and/or about to undergo a procedure.
- Hospitals purchase child friendly equipment and consumables – items that are colourful. Some oxygen masks for example have different smells so children enjoy smelling them – this encourages compliance.
- Unless paediatric blood pressure cuffs are available, many anaesthetists may not routinely do a blood pressure check on a child. Ask the anaesthetist for their preference.
- Before inserting an IVC, numbing creams (i.e. Emla) can be placed onto the area intended for insertion.

This means that when the staff member inserts the IVC, the child may not feel it quite as much.

- Depending on the hospital (but more so for day surgeries) the child is allowed to remain in the clothes they arrived in – assuming their clothes are relatively clean. This alleviates the distress of dressing in OT clothing. Instead, they wear shoe covers and a hat. Once asleep in the OT, the team places a blanket over them to cover their day clothes.
 - alternatively, child friendly surgical gowns can be used, i.e. patterns of super heroes or cartoon characters.
- One parent/carer is welcome to sit with the patient in the recovery area once the recovery staff are happy that it is safe to do so:
 - Note: this can only be done if it does not place other patients at risk and it does not contravene privacy rights of other patients. Also the parent/carer needs to agree to adhere to instructions from the recovery staff (i.e. they must allow them to continue their monitoring and treatment of the child), and to leave when instructed to do so by the recovery staff –which might be required in the event of a medical emergency for any patient in the recovery area.

Paediatric GA administration and monitoring is outside the scope of this textbook. It is recommended that where surgery is performed on children, that staff have completed specific training in the management, care and emergency procedures relating to children. Well-resourced hospitals in the region may also have specially trained paediatric anaesthetists who may be able to advise or provide training.

Photo 4b.1 and 4b.2: Child friendly environment



Sickle cell disease

This is a group of genetic blood disorders, causing an abnormality in the oxygen carrying protein haemoglobin in red cells. The red cells become rigid and sickle-shaped when there is a temperature change with, stress, dehydration and at high altitude. It causes attacks of pain, anaemia, bacterial infections, and stroke.

This genetic disease is very common in patients of sub-Saharan African, Indian and Arabian Peninsula descent.

It is important for these patients to maintain steady body temperature. Give IV fluids and carefully monitor temperature, oxygen levels and urine output.

Infectious diseases

Infectious diseases such as AIDs/HIV and malaria are common and careful aseptic technique must be used at all times.

Patients who are overweight (or morbidly obese)

An overweight patient is a concern to the anaesthetic team, i.e. difficulty inserting an IV, maintaining airways and oxygenation, management of acid reflux, diabetes, hypertension and heart disease. In particular, patients with obstructive sleep apnoea are at high risk of respiratory complications and need to be managed in an appropriate centre. The anaesthetist may need to liaise with the surgeon to find a way to slightly elevate the head end of the table, or explore additional anaesthetic options. For the person with morbid obesity, who is scheduled for a GA, it is always important to notify the anaesthetist so they can make sure an anaesthetic has been designed specifically.

For operations that will take more than 30 minutes, there should be consideration of pressure points and circulatory problems. The goal is to prevent skin breakdown and/or the formation of blood clots in the legs. Facilities are advised to use the following guidelines:

- A strict ASA rating assessment is conducted.
- If a person's ASA rating does not match the facilities service level, then the surgery must be re-scheduled at a facility that can provide the necessary level of care.
- GA risk can be reduced by changing to a local (+/- sedation) anaesthetic – however it must be established whether the patient will cope, and if the type of surgery can be performed with this type of anaesthetic. This needs to be considered on a case by case basis.
- Surgery may be postponed. Patients may be asked to reduce their weight prior to being rescheduled for surgery – this may require referral to a dietician or health-planner so the patient can be supported to reduce their weight.
- For those who will undergo surgery, the hospital may require the patient to wear compression stockings or they may use a mechanical leg compression device to help promote good circulation, and help to prevent deep vein thrombosis and pulmonary embolus. This is not routinely available around the world.
 - Also consider anticoagulation with subcutaneous Heparin or Enoxaparin (Clexane) for prolonged cases if available.
- It is also important to check the weight of the patient against the weight of the OT bed's hydraulics. A hydraulic system is the mechanism that pumps a bed up and down. If the patient is heavier than what the bed can cope with, it is important that the bed is not pumped up as the hydraulics may break. In this instance, the surgeon needs to be notified as this will impact on the height at which they must sit/stand to perform the surgery.

Patients with a mental, intellectual or physical disability

- Always review this patient's ASA rating in relation to the hospitals' level of service and ability to care for this group of patients.
- Provide the healthcare team with education on the various types of disabilities that they may encounter, to help them provide appropriate care.
- Ensure the environment is calm, comfortable and appropriately equipped (i.e. ramps for wheelchair access).
- For persons with a mental and intellectual disability:
 - Ask their family member/carer (or the patient) as much as possible, i.e. their likes, dislikes and/or phobias so care can be planned accordingly.
 - Invite one family member/carer to escort the patient into the OT until the patient is asleep for a GA (or have them stay the whole time for a local anaesthetic). This helps alleviate distress and assists the team to communicate with the patient.
 - Invite one family member/carer into the recovery unit at the earliest and safest time so there will be a familiar face to support the patient as they recover from the anaesthetic.
- Ensure discharge post-operative instructions are appropriate and practical so they can be followed – you may need to spend additional time explaining and demonstrating instructions.

Patients with language and communication difficulties

Language is an important aspect of communication, and our ability to communicate with a patient is an essential aspect of care. It also promotes patient compliance and confirms comprehension. There are a variety of reasons why a language-communication barrier might occur, i.e. deafness, second language speakers, age, dyslexia, illiteracy and/or intellectual or physical disabilities that have impacted on parts of the brain responsible for speaking and listening (interpretation) and memory retention.

As outlined in section 1, it is the responsibility of the healthcare providers to provide equal levels of care regardless of a person's situation. Here are some examples of what can be done to assist with the care of persons with language and communication difficulties:

- Examine their ASA rating and ensure the facility is equipped to care for this patient group.
- Consider developing management plans in consultation with experts from disability or language/learning special-needs groups.
- For second language speakers:
 - insist that a family member/carer who can translate between languages is available at all stages of a patient's stay. They may also accompany the patient into the OT and/or recovery unit.
 - hire a translator in the event that there are no family members/carers to assist.
 - provide written instructions (and the consent if possible) in a language they will understand.
 - use of a translator phone system (telephone interpreters convert the spoken language using a dual phone system—patient has one phone and the nurse/doctor uses the other).
 - use a downloadable language/translation app on a smart phone. While not always contextually accurate it may help with basic instructions and cues.

Anaesthetic Emergencies

Anaesthetic complications can occur at any time after the administration of an anaesthetic. Exploration of all the issues is beyond the scope of this text however the information below will briefly outline five important complications – laryngeal spasm, emesis, malignant hyperthermia, cardiac arrest and emergence agitation. (Schick, 2016) It is advised that anaesthetic and recovery staff undertake specialist training to assist them with identification of these and other complications.

Laryngeal spasm

Laryngeal spasm is a spasm of the vocal cords. It occurs when the muscles of the vocal cords seize up and restrict airflow into the lungs. If partial, the patient's respiratory efforts are laboured and they will make a 'crowing' noise (stridor). If it is a complete spasm there is greater respiratory effort but no air can get in or out of the chest. Patients quickly become cyanosed. It can be caused by pushing an oral airway into a patient's mouth when their conscious level has recovered and they cannot tolerate it, or when removing the endotracheal tube. Secretions on or near the vocal cords and over-enthusiastic suction can also cause spasm. Oxygen should always be given at the first hint of spasm as it may become worse if neglected; fortunately, it usually resolves with oxygen alone. Perform a chin lift to ensure the airway is unobstructed and apply gentle positive pressure through the oxygen circuit. If this does not resolve the laryngospasm, the patient may need to be reintubated using Suxamethonium to aid intubation.

Emesis

This occasionally occurs, and refers to a patient vomiting after anaesthesia. A suction machine and catheter must always be available nearby and staff should be competent in oral and nasal suction procedure. Consider turning the patient on to their side, if unconscious, to prevent aspiration of acid gastric contents.

Anaphylaxis

This is an allergic response. It may be caused by anaesthetic drugs, particularly muscle relaxants including Suxamethonium, antibiotics, IV colloid solutions, chlorhexidine prep, and latex.

The allergic response causes low BP and/or bronchospasm and may not responding to treatment. **THIS IS AN EMERGENCY.**

Response includes:

- cease triggering agents
- stop the procedure if possible (depending on the anaesthetic type and phase of anaesthesia)
- send for help if available
- intubate the airway
 - if the airway swells or there is difficulty maintaining the airway, then give 100% oxygen.

If required, the anaesthetist may require assistance, such as preparing:

- 1mg Adrenaline (paediatrics 10 mcg/kg) if there is no pulse
- IV fluid - give 20ml/kg bolus and repeat as required
- IM Adrenaline 1:1000 (1 mg/ml) (0.5ml) to adults, into the lateral thigh or for:
 - under 12 yrs, give 0.3ml
 - under 6 yrs 0.15ml
- IV Adrenaline boluses
 - draw up 1mg Adrenaline in 10 ml- this makes 100mcg/ml solution. Give dose every 1-2 mins if needed

- moderate hypotension & Bronchospasm
 - Adult 0.05 - 0.2ml
 - Child 0.01 - 0.15ml/kg
- severe hypotension and bronchospasm
 - Adult 1 - 2ml
 - Child 0.05 - 0.1ml/kg.

Malignant hyperthermia

This is a rare, hereditary life-threatening condition that causes hypermetabolism of skeletal muscle. Triggering agents include volatile anaesthetic agents (Halothane, Sevoflurane etc.) and Suxamethonium. (Visoiu et al, 2014) The symptoms of malignant hyperthermia include muscle rigidity, tachycardia, rising CO₂ levels, and hyperthermia. Immediate administration of the drug Dantrolene is critical, initially 2.5 mg/kg to 10mg/kg, and extra staff will be needed to help. (Schick,2016) Surgery should be stopped as soon as possible, and any volatile anaesthetic gases need to be discontinued. If available a volatile free anaesthetic machine is used, with high flows of oxygen, and cold IV fluids given. Dantrolene is difficult to mix. The patient will need intensive care follow up, or transfer to a unit where such care is available.

Cardiac arrest

This occurs when the patient is not breathing and has no pulse. Immediate management:

- D** check for surrounding danger
- R** is the patient responsive
- S** send for help
- A** open airway
- B** is there normal breathing
- C** if not start CPR. 30 chest compressions to 2 breaths
- D** attach defibrillator.

(American Heart Association, 2010)

IMPORTANT: ACLS discussion is beyond the scope of this text. Please check current CPR and ACLS guidelines for rates of compression to breath, advised shock levels, front line drug administration and how to assist during this type of emergency.

Emergence agitation

Anaesthesia gases such as Sevoflurane, and drugs such as Midazolam may cause transient emergence agitation to the patient. (Mason, 2004) This often occurs when they are in the recovery room. For example, a child may become inconsolable, cry incessantly, behave incoherently and thrash around in the bed. They do not recognise their parents or favourite toy/blanket. Generally this lasts 5-15 minutes and parents/carers need to be reassured that this will pass. Protecting the patient from self-injury is of utmost importance during this period. If necessary, treatment of emergence agitation can include clonidine, opioids, Midazolam, Propofol or Flumazenil.

Recovery (Post-Operative Care)

Once the surgery has been completed, the patient will be transferred to the recovery unit. Once there, the patient will be directed into one of two care areas.

- stage 1 – This is immediate care of all patients who have had a GA
 - the area can also be used for some drowsy and non-ambulatory local anaesthetic patients
- stage 2 – For all patients who have had topical and local anaesthesia.

The handover

The term handover refers to the transfer of care from one healthcare professional to the next. A correct verbal handover from the OT representative to the receiving recovery nurse (Schick, 2016) should include information on the patient's:

- name
- age
- surgery they have had and name of the surgeon
- anaesthetic they received
- complications encountered (surgical or anaesthetic) if any
- post-operative requirements – i.e. medications that the recovery nurse needs to administer
- discharge requirements
- list any important medical facts about the patient:
 - allergy
 - medical history
 - surgical history
 - social history
 - communication issues

The OT Team shall also provide:

- all chart documents and x-rays
- written post-operative medications (or other) that the surgeon/anaesthetist requires the recovery nurse to administer
- any prescriptions that need to be handed to the patient at discharge
- any medications (i.e. eye drops/ointment) that need to be handed to the patient at discharge
- any belongings.

Recovery from general anaesthesia

The role of the recovery nursing team is to assist patients to recover to a safe level of consciousness ready for discharge - either to the ward or home with their family member/carer. The team is required to identify, prevent and/or rectify adverse events such as airway obstruction, agitation, early signs of deterioration such as abnormal vital signs readings, chest pain, and nausea and vomiting. (Schick, 2016)

WARNING: Recovery is a critical time for a patient and less serious concerns can escalate into serious adverse events very rapidly. Therefore the staff need to be encouraged to call for help at any time they feel concerned about a patient. Emergency systems must also be in place and emergency equipment in close proximity.

WARNING: Patients should never be left unattended in the recovery areas.

There are two stages of recovery generally seen in eye care facilities around the world. They may vary slightly between general hospitals which tend to transfer patients from recovery to the ward, as opposed to day stay facilities that transfer patients from recovery and into the care of the patient's family/carer. Additionally, how recovery nurses determine a patient's 'post-operative recovery state' depends on the recovery and discharge system in place at their facility and the type of services they provide. This next section will provide an overview of what is, generally, found in eye day surgery recovery units. It will also provide some examples of recovery grading scales. Grading scales help to determine if a patient is ready to leave the recovery unit.

Stage 1 recovery

Two recovery nurses trained in airway management and GA care need to be assigned to care for a patient entering the recovery area. Once the patient's endotracheal tube has been removed and the patient is breathing independently, the staffing level can be reduced to one nurse for one GA patient.

As the patient starts to become more alert, the patient-to-nurse ratio can be reduced the one-on-one. The nurse can also use this time to prepare the patient's notes and discharge needs.

WARNING: Every patient is different, so the recovery nurse needs to use their judgement, based on their experience, training and knowledge to determine if patient care is progressing as planned, and to determine if more nursing time and support is required. This is to ensure patient safety remains the priority.

WARNING: If the recovery unit is getting too busy – to an unsafe level, and there are not enough nurses to facilitate safe care, then the manager needs to notify the OT Teams and seek to delay the transfer of patients into the recovery area until the backlog can be cleared. This can easily be done by recommending that the OT Team take a short 10-15 minute tea break before starting their next case. If all OTs did this, then it would help the recovery team catch up and ensure all patients are provided with equal levels of SAFE care.

Observations

Upon arrival in the recovery unit, the patient's vital signs are continuously monitored every 5 minutes until they are awake, appropriately responsive, and breathing at a normal rate (until their airway has been removed). Observations are then reduced to 15 minutes until patients are more alert – at which point observations can be further reduced to 30 minutes until discharge. The length of time that this entire recovery process takes can vary with the patient's age, other medical issues, or complications of surgery. Observations include:

- Looking at the patient:
 - are they breathing?
 - do they need supplemental oxygen?
 - what is their level of consciousness? Are they rousable?
 - are they complaining of pain or nausea?
 - is the dressing dry and intact?
 - is their IVC patent and working (if applicable)?
 - do they look unwell?
- Feel peripheral limbs/compress a finger nail:
 - are they warm with good circulation?
- Completing and recording routine observations:
 - pulse/heart rate
 - oxygen saturation levels
 - respiration rate
 - blood pressure (adults only)
 - temperature
 - blood sugar level if diabetic.

Once a patient has reached a stage of alertness, where they can (case-by-case dependent) sit up, and/or talk to the nurses, they may be transferred to Stage 2 of recovery (if in a day stay facility) or transferred to the wards for ongoing care (if in a general hospital facility). (Schick, 2016)

Stage 2 recovery

In stage 2 recovery, one nurse may be responsible for more than one patient at a time. The actual ratio of patient-to-nurse will depend on hospital policy, the type of patients and their needs.

As most ophthalmic surgeries (except for paediatric surgeries) are conducted under local anaesthetic, direct admission from the OT to the stage 2 recovery area is common in this specialty. Patients are fully conscious and have an intact airway (meaning they are breathing on their own).

A full handover is still required.

Depending on the facility, patients either stay on the same bed or are transferred to a chair. Either is acceptable but if the patient needs to be walked to a chair, special care is needed to ensure this is done in as safe a manner as possible. For example:

- They are sat up slowly so they can adjust.
- They are asked to put their legs over the bed slowly and remain in that position for a few minutes so they can adjust.
- Before the patient stands up, the nurse will remove any devices and untangle blankets from IVC fluid lines or cords.
- The patient is asked if they are feeling dizzy or ready to stand up.
- Tell them where they will be walked/transferred to.
- If needed, have a second staff member to assist, each standing on either side of the patient.
- Nurses place a foot in front of the patient's toes, and a hand on the patient's back. This will prevent the patient from sliding forward and falling down. It will also help guide them and give them comfort.
- Once the patient is standing – wait a moment before walking so they can adjust.
- Thereafter, walk with the patient to their next destination and guide them gently into the chair.
- Before they sit let them feel the seat against the back of their legs.
- Ensure they are comfortable before leaving them.

Vital signs, similar to those listed above for GA stage 1 Recovery, are conducted once the patient enters Stage 2 and again every 15-30 minutes (depending on the facilities' policy), and again just prior to discharge.

Recovery grading scales

Recovery grading scales are required to determine three things:

1. If there has been an unexpected deviation from the normal recovery path that requires the attention of the surgeon or anaesthetist.
2. If a stage 1 patient can transfer to stage 2 (or the ward).
3. If a stage 2 patient can be discharged from the facility into the care of their family/carer.

A variety of grading scales and tools exist to evaluate a patient's level of recovery and return to that pre-operative physical and mental status. Some use graphs, charts and pictures, while others use note-taking. A combination of all is needed. (Schick, 2016)

Some also incorporate what is anticipated of a normal recovering patient (i.e. their respiration rate is within the expected range), and how the patient states they feel (i.e. they feel pain). A combination of both is needed.

Tools to determine recovery progression

Tools and systems vary around the world. For example:

Strict time-influenced recovery and discharge system

- All patients must stay in each stage for no less than a strict time period regardless of how quickly they have recovered and even if they are ready to leave earlier.
- All observations must be monitored strictly at a set time.
- This system is hospital policy focused.

Criteria based recovery and discharge system

- Patients are able to progress through either stage when they have met certain criteria rather than remaining in each stage for a specific time period.
- This system may mean some patients can leave earlier while others have a prolonged stay.
- Some facilities place criteria into a traffic light system to help alert staff of the patient's status and alert staff to a serious change in the patient's progression, i.e.
 - red – an issue needs to be brought to the attention of the anaesthetist/surgeon
 - patient not ready to go home, i.e. airways not clear, still requiring oxygen, unexpected levels of pain – yet to be managed, unexpected bleeding or oozing etc.
 - yellow – continue with care
 - Almost within normal range and almost ready for discharge. The patient is progressing towards green
 - green – they can be discharged.
 - normal observation ranges (or normal for that patient)
 - airways clear
 - alert, sitting-up and able to tolerate fluids (where applicable)
 - bleeding or oozing within expected range
 - pain manageable and within expected range
- This system is patient centred and individualised.

Grading specifics

For recovery grading systems to work they need, to a minimum, contain key elements outlined in the stage 1 GA list of observations. They can be on a score of 0-10 or on the traffic light system. The nurses are then provided with a range guide which identified whether a patient has reached the appropriate state that that the facility deems as suitable for discharge.

Note: some sections/questions of the grading system may not be applicable for each patient, so the recovery room nurse needs to use their own judgement.

For further information

1. UCLA Department of Anesthesiology and Perioperative Medicine. Discharge Criteria http://www.anes.ucla.edu/perioperative/page1/page5/Discharge_Criteria.html

Pain protocols

Pain protocols are policies developed by some facilities to help recovery nurses determine if a patient's perception of pain has increased over a certain period of time (Schick, 2016). This will help recovery nurses know if they need to intervene by administering pain relief (if prescribed to do so by the anaesthetist/surgeon/facilities standing orders) or seek help from the anaesthetist or surgeon.

Food and fluids in recovery (in the day surgery setting)

Every facility is different and the process of providing food and fluids post-operatively really comes down to culture, resources and safety policies. Many higher resource day surgeries routinely provide light refreshments post-operatively and they factor the cost of this into the patient's stay. Here are some important rules to adhere to when providing refreshments:

- Patients must be breathing by themselves, alert and sitting up. They must have the ability to swallow. If a patient is not able to do so, they should not be provided with refreshments.
- Blood sugar levels need to be checked for all patients with diabetes prior to being given food.
- Stage 1 patients are to start with small sips of water. This is to test whether they can swallow with ease.
- Stage 2 patients start with small sips of water and build up to bigger gulps should they need them. Patients may also take tea, coffee or other drinks if available.
- Culturally appropriate food – which does not induce the sensation of nausea or vomiting - can be provided (i.e. dry biscuits).
- Infants who are breast feeding can commence feeding once safe to do so.
- Sugar drinks, such as lemonade, need to be ready as a back-up for patients who need glucose.
- Lemonade can be given to patients who are feeling nauseous, as the gas bubbles will help settle the stomach acids.
- Do not give hot fluids to oculoplastic patients as the heat may encourage blood flow to the area.
- Make sure, especially with children, that they are not given food items that could occlude their airway.
- Check patient food allergies prior to provision.
- Make sure food does not attract insects and pests into the recovery area. Remove leftovers each day and clean and tidy away crumbs and spills.
- Always wash hands before serving food.

Discharge

Before discharging a patient, please make sure that:

- discharge criteria have been met as per policy
- the IVC has been removed – and there is no formation of a haematoma
- EKG (ECG) markers are removed
- all belongings (including dentures and spectacles) are returned to the patient
- the patient is dressed in their own clothes
- all documentation is complete and signed, and all care has been given.

Routine discharge

Facilities in most locations allow nurses to routinely discharge patients from the facility based on a set standing order and discharge criteria. Some other facilities require the surgeon or anaesthetist to be recalled to the recovery room to sign out a patient once the nurse has deemed the patient ready for discharge. Regardless of the system used, a member of the team caring for the patient needs to sign over the patient to their relative/carer.

Post-operative instructions

All patients who are discharged into the care of a family member/carer need to be provided with instructions on what to expect and

what to do during their home recovery phase. (Schick, 2016) They also need information on emergency contacts and of their next visit with their surgeon.

This process needs to take place in the presence of both the patient and the family member/carer so both are receiving the same messages at the same time. It is best to do this in a private area so there is the opportunity for questions and answers.

Instructions need to be accompanied with demonstrations as appropriate (i.e. how to put in eye drops or how to wash around the eye/s without cross-contamination). Instructions need to be provided in a language the patient understands. The letter font needs to be clear – preferably in a larger than normal font size. Dark letters on light (i.e. black letters on white paper) is best for contrast for vision impaired patients.

Explain what levels of pain or bleeding/discharge they may experience from the operation site so they have a benchmark from which to determine if they need to seek help.

Written instructions need to include:

- what to do until their post-operative surgeon appointment
- avoidance of strenuous activity
- not to rub their eye
- not to remove the eye bandage until seen by the surgeon (unless instructed to do so)
- not to lift more than 3 kilograms
- not to operate heavy machinery
- not to sign any legal documents
- avoid bending over, coughing or straining
- how to store and use their new eye drops/ointment for their operative site:
 - when to commence using them - as instructed to do so by the surgeon
 - wash hands thoroughly before putting eye drops in eye
 - if using several eye drops, instruction is needed with regards to waiting 5 minutes in between instillation
 - if using drops and ointment, drops must be administered first
 - only use a clean cloth to wipe face after instilling eye drops
 - how to identify eye drops by the colour of the bottle cap/label and when each is to be given, i.e. red cap – use twice a day, or white cap - use three times a day
 - explain if some bottles need to be shaken just prior to use
- continue routine medications, including eye drops in the un-operated eye (check with the surgeon first)
- how to bathe the day after surgery without getting the eye wet
- observe safety precautions to avoid bumping their head
- eat a regular normal diet
- take pain relief (if required) as per instructions
- call their doctor if they are having severe pain, bleeding, questions or concerns
- provide an emergency contact number
- date, time and location for follow-up appointment.

Once the patient has visited the surgeon, the surgeon may change the post-operative routine.

Special discharge considerations

Retinal patients:

- Positioning: inform the patient of any specific head positioning instructions.
 - Ensure they are aware of considerations of flight travel or high-altitude road travel which will cause gas bubbles inside the eye to expand.
 - Inform them that they must also notify other health care providers that they have gas in their eye should they be admitted to hospital in the following days/weeks.
 - If they are required to stay in an unnatural position for a long period, they may also experience neck, back and other body stiffness or pain. Therefore, encourage them to try and move other parts of their body regularly.
- Diamox: if prescribed, patients need to take this with food otherwise they may feel sick. Also check for allergies before sending them home with Diamox.

Paediatric patients:

- They do not always go home with an eye patch on.
- Strict compliance is always difficult with very small children and they often rub their eyes. Parents can become quite distressed when they cannot stop the child rubbing their eyes. Try and find ways to alleviate the parent's anxiety.
- Many children can go home and play as much as they like but it might be best if they stay indoors for a day or so.
- The surgeon may not need to see them the next day (i.e. their follow-up might be in one week's time). Therefore, it is important they understand the post-operative instructions and follow-up very carefully.

Oculoplastics, minor procedures and/or topical anaesthesia:

- Depending on the type of surgery, patients may or may not have a dressing.
- The surgeon may not need to see them the next day (i.e. their follow-up might be in one week's time) therefore, it is important they understand the post-operative instructions and follow-up needs very carefully.
- Remind them about avoiding hot fluids for the first 24 hours.

Persons with routine eye drop regimes:

- It is important to find out if a patient, i.e. with glaucoma who normally has a daily eye drop regime, needs to continue with or cease using their regular drops in their operative eye post-operatively. Some surgeons may cease regular drops while others may not. This can be very confusing for the nursing team so please make sure the surgeon's wishes have been confirmed and conveyed to the patient.

Eye drops and persons with arthritis or hand/arm disabilities:

- Check that the patient and/or their carer know how to administer eye drops or eye ointment.
- Keep in mind that someone with arthritis or hand/arm disabilities may not be able to administer their own eye drops because they have difficulty holding or squeezing the bottle.
- Available in some parts of the world are special devices that the eye drops can be placed in. The device squeezes the bottle without the patient having to squeeze too hard. Patients can purchase these.
- If there is a concern about the patient's ability to self-administer, it is important to teach the family member/carer how to administer the eye drops accurately and without contamination;

- alternatively notify the surgeon that there may be compliance issues.

Post-operative follow-up

In some parts of the world, ophthalmic nurses telephone every patient 1-3 days after their discharge date to check how they are recovering. This also provides an opportunity for the patient to ask any questions. An alternative to this is that some facilities only telephone those patients who do not visit the surgeon on day one post discharge (i.e. paediatric and oculoplastic) and those who may have experienced a complication during their stay.

This is a useful system for those patients who might not be seeing their surgeon again for another week or more.

Non-routine discharge - patient self-discharge

Sometimes a patient will demand to be discharged from a facility against the advice or wishes of the healthcare team. This can happen pre-operatively, post-operatively and in the wards. This can sometimes be difficult and distressing for both the patient and the staff.

In the end, with the exception of patients who may not be of sound mind to make a decision, every patient has the right to decide when, where and how they need healthcare – even if it goes against everything the healthcare team recommends. If experiencing a patient who demands to be discharged, it is important to:

- Ask them why they want to leave, and seek to alleviate any of their worries.
- Explain to them why it is important that they stay.
- Notify the surgeon/anaesthetist so they can try and convince them to stay.

If, after the surgeon/anaesthetist has tried, and the patient still insists on leaving, preparations for their self-discharge are needed. Depending on the facility this may include:

- Asking them to sign a discharge form. This form should outline that the patient has selected to self-discharge and that they waive their right to bring a legal charge against the hospital and surgeon should their discharge result in negative consequences to their health:
 - the patient needs to sign the form and a member of staff to witness this.
 - a copy of the form goes with the patient and another stays in the chart.
- A member of the team needs to document, in the chart, that the patient elected to self-discharge despite the advice of the team and surgeon.

These steps are important to protect the hospital, the surgeon and staff from legal issues.

References

1. American Heart Association (2010). Highlights of the 2010 American Heart Association Guidelines for CPR and ECC. 2010. www.heart.org/idc/groups/heart-public/@wcm/@ecc/documents/downloadable/ucm_317350.pdf. Accessed 20th June 2016.
2. American Society of Anesthesiologists (ASA). 2011. Practice Guidelines for Preoperative Fasting. <http://www.asahq.org/quality-and-practice-management/standards-and-guidelines> Accessed 20th June 2016.
3. American Society of Anaesthesiologists. (ASA). 2014. ASA Physical Status Classification System. <https://www.asahq.org/resources/clinical-information/asa-physical-status-classification-system> Accessed 20th June 2016.
4. Bartlett, J. D. Jaanus, S. D., & Blaho, K. E. *Clinical Ocular Pharmacology*. 2001. Butterworth-Heinemann. Boston.
5. Eger, EI (the 2nd). Characteristics of anesthetic agents used for induction and maintenance of general anesthesia. *Am J Health Syst Pharm*. Oct 15 2004; 61(20).
6. Guise, P. Sub-tenon's anesthesia: an update. *Local and Regional Anesthesia*. 2012; 5, 35-46.
7. Lamb, P., & Bataoel, A, (editors). *Core curriculum for ophthalmic nursing: pharmacology*, 3rd ed. American Society of Ophthalmic Registered Nurses. 2008. San Francisco.
8. Mason, L, J. Pitfalls of Pediatric Anesthesia. 2004. http://www2.pedsanesthesia.org/meetings/2004winter/pdfs/mason_Pitfalls.pdf Accessed 20th June 2016.
9. Polansky, M. Airway management: the basics of endotracheal intubation. *The Internet Journal of Academic Physician Assistants*. 1996; vol 1 (1). <http://print.ispub.com/api/0/ispub-article/3346> Accessed 20th June 2016.
10. Press, C, D. General anesthesia overview. *Medscape*. 2015; 30 Nov. <http://emedicine.medscape.com/article/1271543-overview>. Accessed 20th June 2016.
11. Schick, L. *Perianesthesia Nursing Core Curriculum*, 3rd ed. 2016. Saunders- Elsevier. Philadelphia
12. Simonson, D. Retrobulbar block: a review for the clinician. *Journal of the American Association of Nurse Anesthesia*, Dec 1990; (58), 6 www.aana.com/newsandjournal/Documents/retrobulbar_block_1290_p456.pdf. Accessed 20th June 2016.
13. Treitel, K. Mechanism of action of local anesthetics. *Journal of the American Dental Society of Anesthesiology*, 1965; 12(5), 143–147. <http://pmcc.web-t.cisti.nrc.ca/picrender.cgi?accid=PMC2033252&blobtype=pdf> Accessed 20th June 2016.
14. Visoiu, M, Young, M, C, Wieland, K., & Brandom, B, W. Anesthetic drugs and onset of malignant hyperthermia. *Anesthesia Analgesia*. Feb 2014; 118(2) 388-96.

SECTION 5

Operating Theatre Processes.

Contributors: Elise Chick, and Heather Machin, and Sofia Solazar Tamay



The Operating Theatre (OT) - or the Operating Room as it is sometimes called - is a unique area of health care dedicated to providing surgical treatment. It is during this phase of care when patients are at their most vulnerable. This section discusses how the OT is designed and how healthcare providers working within the OT complex, can provide uniform safe care.

Theatre Design

The OT complex must be suitably designed to provide safe and effective care. Additionally, the size of the OT complex needs to accommodate extra space for pre-operative, anaesthetic, post-operative and sterilization rooms, plus space for storage and staff needs (i.e. bathrooms and break rooms).

When designing an OT complex

There are many different ways to build an OT complex. When involved in the build of a new complex, it is advised that the building team visit as many other complexes as possible to determine what works and what does not work.

It is also a good idea to consult other eye nurses and professionals who have been involved in building facilities in the past as they will have a lot of useful suggestions on what to do, and what not to do – this means, you can learn from their experience. The more people involved in the design, from a wide group of experts, then the better the facility will be. This includes consulting senior and junior nurses, doctors, administrators, cleaners and builders. Everyone works in the facility and everyone will have valuable suggestions to share about their work area. This information is vital and will help the core design team ensure as many ideas as possible are considered within the budget and space constraints. Note: the core design group must have representation from all groups.

Space

Try and use the space as best as possible so there are no wasted areas (Diagram 5.1).

OT Rooms

- How many OT rooms are needed? How many can fit in the space without making them too small?
- Will a side “set-up” room be required? This is common in some countries but including this in a design needs to be considerate of specific airflow and traffic patterns to prevent cross-contamination.
- Will the facility be offering General Anaesthetic (GA)? If so, additional design is needed to ensure appropriate plugs, scavenger, oxygen and suction outlet systems are in place. It is necessary to discuss this at the early design phase as these will need to be built into the walls within the OT (as well as in other parts of the facility).
- Will the airflow system include High-Efficiency Particulate Air Filters (HEPA filtration) and/or a positive and negative airflow system? These are both recommended.
- How big should the OT rooms be? Keep in mind:
 - a standard patient operating bed (also called a table/trolley/gurney) is about 1.85m long
 - instrument trolleys are about 0.9 m long;
 - will additional Mayo tables be needed?
 - a working space of about 1.2 m around the table is required
 - more space is needed if the OT requires microscopes, anaesthetic machines, phaco machines, vitrectomy machines, monitors, etc.
 - are there any local, legal building regulations to be aware of?

- can the patient bed move into and out of the room easily? Can they be placed both length and width way? Are there tight corners that will make this difficult – can this be avoided?
- will each OT need an anaesthetic preparation area or can they share an area?
- what is the access and proximity to a scrub-sink?
- will the water taps be hand, sensor or foot operated (Photo 5.1) – will filters need to be placed?
- will the doors be automatic, sliding or manual?
 - remember space is needed for ‘swinging doors’. This will mean some dead space
 - placing a small window in the door will help prevent issues with people opening and closing the doors
 - ensure the door placement does not hinder movement of the trolley into and out of the room.

Photo 5.1: Scrub sink



Sterilization department

- The sterilization area should be adjacent to the OT rooms.
- Allow for clean, dirty and storage areas – preferably separated by doors and different airflow systems.
- Ensure there is filtered/quality water plumbed in to the area.
- Ensure waste water drainage for the area is also provided – this may be needed for fixed-installed sterilizers too.
- Allow space for the general and contaminated waste storage areas and dirty linen storage areas.
- Placement of the storage rooms needs to consider proximity to both the sterilization department and the OT.
- Air control is also needed. If possible, provide positive air in the clean room and negative air in the dirty room.
- Adequate space for stand-alone or benchtop equipment, i.e. benchtop sterilizers.
- Ensure benches are strong enough to hold the weight of heavy equipment like sterilizers.

Ancillary rooms/corridors/other areas

- Access for staff to enter and exit each day.
- Changing rooms (male and female) including space for bathrooms +/- showers and locker storage areas.
- Staff break-out rooms, i.e. tea room and doctors’ write-up desk space.
- Patient entry and waiting areas. This may differ between overnight hospital facilities and day-stay-units.

Diagram 5.1: OT Design

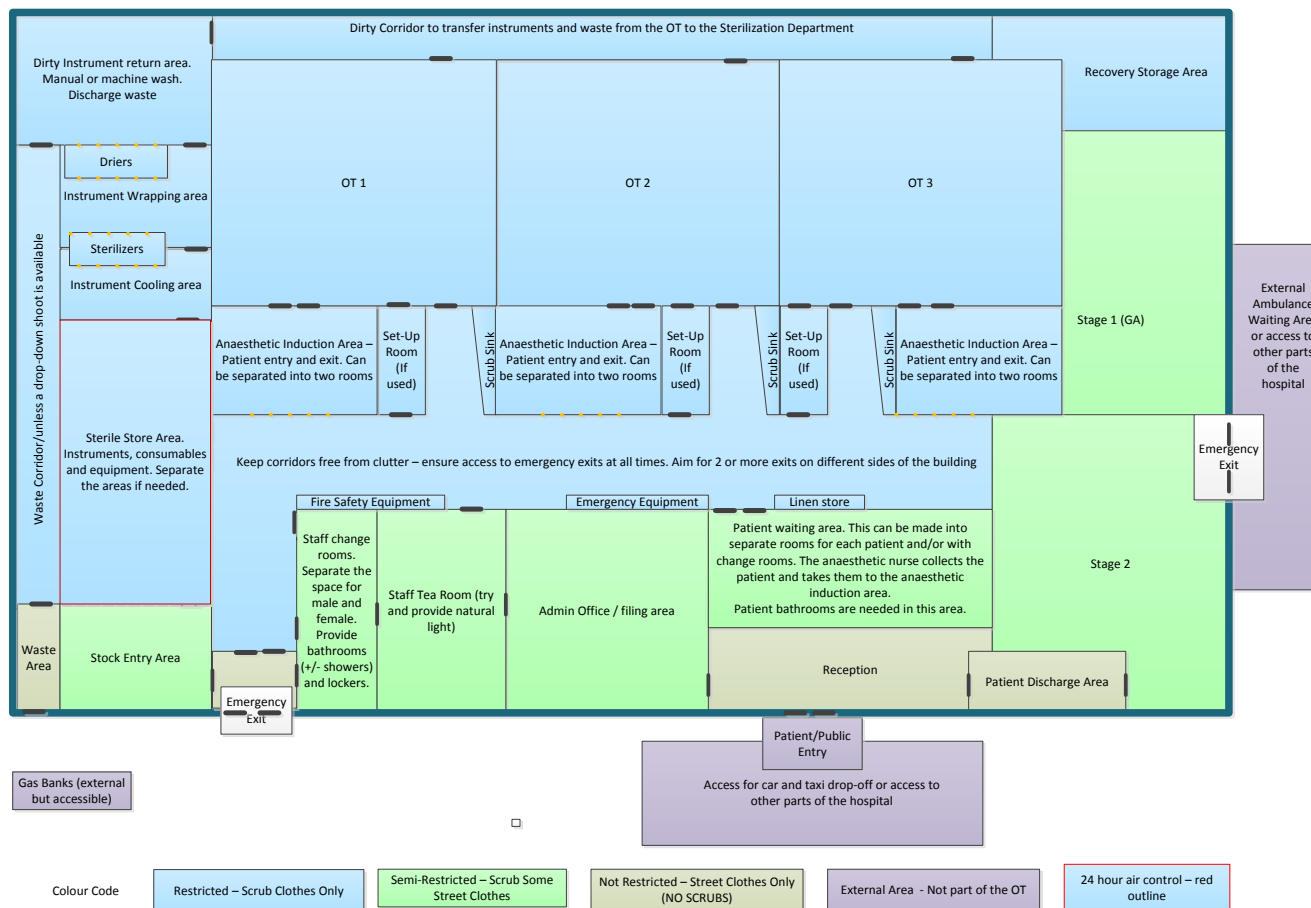

Emergency and safety

- At least two exit points
- Access ramps if the OT complex is not on the ground floor. This will assist with:
 - fire evacuations
 - access to the ambulance day (for day-stay-units) or intensive care (for general hospitals) for medical emergencies.
- Proximity to fire equipment and alarms.
- Proximity to the gas cylinder banks so they can be isolated in an emergency (and routinely managed day-to-day).
- Space for waiting relatives, if a day-stay-unit.

The Work Environment

- good space – rather than squashed in
- natural light
- window covers for laser use
- air conditioning – especially in hot and humid climates
- windows/doors with insect screens.

Floors, doors and walls

- Tiles and wood (organic material) should not be used if possible. This is because grouting in the tiles can become dirty and harbour bacteria and fungus. Wood (that does not have a protective coat) can also harbour bacteria and it can expand when wet if not monitored – which could also lead to mould. Consider the options based on the budget and available materials, i.e.
 - if wood is the only option then insist on treated wood
 - if tiles and grout are the only option then ensure the tiles

and grout are cleaned daily and sealed/waterproofed regularly.

- The floor should be smooth and slightly sloping towards the skirting (sides of the wall) to reduce the amount of water that pools in the middle, after the floor has been washed. Stone or terrazzo floors are easy to keep clean and wear very well even with frequent cleaning.
- Slight curves should be placed on the floor, and ceiling corners also help prevent dirt to accumulate in the corners.
- Preferably, doors should have a window so staff can check before opening.
- Doors, where lasers are used, also need to have laser ‘shutters’ to cover the windows.

Ceilings

- Designs need to consider airflow.
- Do not use ceiling fans. Only appropriate airflow (conditioning) systems should be used.
- Principally, never place the airflow unit directly over the patient-bed area or in a position where they blow directly on the patient-bed (surgical site) area. This helps reduce the amount of air movement in the middle of the room – thus reducing the movement of air particles from landing on the surgical site.
- If using a ceiling-mounted-microscope, make sure the ceiling is reinforced to carry the weight.
- Keep in mind over-head lights as they will need electrical access.
- Keep in mind the oxygen and suction outlets as these too may need to be placed appropriately (ceiling or wall).
- Remove cables from the floor to prevent staff from tripping and cables from becoming damaged to do this place plugs on the ceiling (Photo 5.2).



Photo 5.2: Cables up off the floor



Photo 5.3: Shelving

In some parts of the world, stock is no longer allowed to be stored inside the individual OT rooms – with the exception of regular stand-by items which are secured in drawers. Generally the nurses must put together their set-ups in a general store room and then wheel the set-ups to a side set-up room, prior to the start of each surgical list. They then bring in one set-up at a time (often arranged into baskets) to the OT. At the end of the day, they wheel the trolley back and unpack the leftovers back onto the shelves. This helps consolidate and monitor stock levels – thus preventing over-purchasing (and preventing expiration of items). It also reduces clutter in the OT.

Emergency items that are allowed to stay in the OTs must be kept in a closable draw or cupboard to prevent dust from falling on them. They must be kept away from wet areas too. Therefore, storage inside the OT is generally taken up with equipment and spare copies of paperwork items rather than sterile stock.

Practice is very different in some lower resource locations – primarily because the plan of the building, generally, does not allow for adequate storage rooms in the OT complex. Due to this, some low resource locations have excess stock – of everything – in each OT, as well as in their store room. It makes finding items very difficult. It also makes cleaning very difficult and it attracts dust. Lastly, it increases the workload for managers and accountants to try and track items at stock-take time.

An example of the items to keep in the OT – within closed drawers or cupboards. Each OT only needs about 3-5 of each item.

- rycrofts
- cystertomes
- common syringes and needles
- cotton tips and Raytec
- balanced salt solution and giving sets
- common sutures
- gloves.

OT complexes are notorious for always needing more space in which to store items. There should be a storeroom with shelving adjacent to the OTs, and some shelves and instrument cupboards inside OTs and sterilizing area.

The shelves should be:

- In a temperature controlled area.
- Made from slatted metal (Photo 5.3) or terrazzo. Basically, a material than can easily be cleaned without rusting or becoming ruined.
- Built, starting at about 30 cm from the ceiling and finishing at about 20 cm from the floor. This is to prevent ceiling dust landing on items and prevent dirt from the floor, landing on the items.
- When organising shelved items, keep in mind workplace health and safety principles. Consider;
 - weight and size of the items (i.e. donnot put heavy packs up high)
 - frequency that a particular item is used – i.e. place commonly needed items (like cataract sets/single items) closer to the door and at arm height so they can be grabbed quicker, while lesser used items can go further back into the room. This is to reduce the time it takes staff to find something in a hurry
 - placing similar items in a group (i.e. place all the intraocular lenses (IOL) in the same section).

Equipment storage

The easiest way to store equipment is in an empty room with nothing else inside it. The rooms need to be temperature controlled in order to prevent mould (in hot climates) from damaging the equipment. This is particularly important for the microscope.

These rooms need to be big enough to house equipment between use. Keep in mind that space to walk through each room and between the machines is also needed. They can never be large enough so have them built as large as possible.

These rooms can hold: IV poles, spare tables, vitrectomy machines, cryomachines and much more.

Cylinder banks

If using cylinders, consider storage and access between use and keep in mind the principles of safe storage and management (i.e. they need to be standing up-right and secured to a wall or bracket).

- Consider access to the bank for suppliers (and their trucks) as these items are heavy too, and consider how quickly it is for the OT team to access the banks.
- Many facilities provide a cylinder bank space that is at the back of the complex. This allows the trucks to deliver. It also allows staff to access it.
- Consider the workplace health and safety issues of moving heavy cylinders and purchase a cylinder trolley, designed to help transfer a cylinder safely, without injury.

WARNING: Cylinders can be dangerous. Make sure they are stored in a locked area that is only accessible to the maintenance team and to the OT staff member/s responsible for getting new cylinders or swapping over cylinder banks.

Electrical sockets

- Socket outlets should be mounted on all walls, ceilings, or, if possible, sunk into the floor, though these need to be carefully planned, because if not cared for, they can become a trip hazard, as well as dangerous
 - check that they are not positioned close to water (or areas where water can spill into them).
- The fuse box needs to be within or close to the OT so it is accessible.

- All the sockets should be double with the potential to increase electrical capacity if needed. The position of the operating table and bed needs to be decided, before placing the electrical sockets, in order to make sure that the equipment can be plugged into the wall and can reach the operating table at the same time.
 - wires lying around the floors are a hazard. Sockets should be close to the pieces of equipment they will serve. All sockets must be properly earthed and of a safety type that prevents the switch being turned on if no appliance has been plugged in.
- Ophthalmic surgery is very delicate and can be dangerous if the operating conditions are not favourable. Therefore, the OT must have a back-up electrical supply (generator) in case the main electricity fails. The operating microscope, anaesthetic machine/monitoring, lights and boiler should all be capable of being powered by a generator or battery. Generators must be of sufficient capacity to simultaneously support sterilizers, microscopes and lighting.
- An alternative fuel supply, e.g. gas or kerosene, should be made available if there is no generator, however as these are both flammable and should not be considered as the first method unless it is a rural setting without other options.
- If the electrical system is not very reliable, it is also worthwhile putting all machinery onto voltage regulators. These stabilise the electrical input and protect the equipment from blowing fuses and bulbs.
- Try not to use electrical extension cables or mother boards as these can cause electrical damage if they are over-used.

Water

Water is essential for the effective running of an OT. Good quality, as well as a good quantity, is important. Supply may be provided by: town water, rain water catchment, bore holes, reliable main supply or tanks. Tanks also need to be maintained. Planning ahead is important because, if there is no water, then the surgical team will not be able to scrub and the sterilization team will not be able to clean the instruments.

The quality of the water is also important – especially for the instruments, so filtered water is the best. Access to special types of water, such as distilled water, is also needed in the sterilization room.

Facilities with larger built-in sterilizers will also need to ensure the sterilizers have both electrical supply and filtered water supply (and water exit drains) in place.

WARNING: Consideration for the safety of water and electricity in the same space is needed at all times to prevent electrocution.

Security

OT equipment and instruments are very expensive and delicate. Therefore, it is important to keep the complex secure. Locks should be placed on doors and cupboards. Monthly inventories of all consumables, and especially IOLs, are also a deterrent to theft. Items should be returned to their storage area at the end of each day so the team know where to find them ready for the next day.

Be careful not to lock emergency exits from the inside. While doors can be locked to prevent people getting in, it is important that those inside can get out in the event of a fire.

Lighting

Good lighting is needed in the OT at all times.

This can be achieved with portable operating lights and/or overhead ceiling-mounted lights. If choosing the latter, ensure that the roof beams are sufficiently strong to take the additional weight. Light switches should be easily accessible and labelled.

Lights which have ‘dimmer’ capabilities are preferred, as the intensity can be changed to suit the surgeon’s needs (i.e. reduced to make the room darker for retinal surgery, but bright for oculoplastic surgery).

It is often the OT nursing personnel who have the best knowledge for building an OT. The architect needs to work closely with clinical staff at the design stage.

Multi-Bed OT

Some parts of the world allow for more than one patient to be operated on at the same time within the same OT room, while others have a strict one-patient only policy to prevent infection and confusion.

Where able, always aim for one patient per OT at a time, or strive towards this in future practice change or structural facility upgrades. In the instance that this is not possible, strict infection control processes must be in place to prevent cross-contamination. Privacy policies may also need to be reviewed.

Dress Code, Personal Protective Equipment (PPE) and Personal Hygiene

To maintain the necessary standard of cleanliness, all OT staff need to wear special theatre clothing in order to minimise the risk of cross-infection. Theatre clothes are changed each day and must not be worn outside the OT complex. Dresses and trouser suits are suitable. The material should be cotton or polyester/cotton for easy washing and drying and low-lint. They should have pockets and be available in a variety of sizes.

Head coverage

Hats/scarfs must be worn to cover the hair completely. Hair is always a potential source of infection, even if clean. Hats can be made out of Jinja cotton with an adjustable tie to allow for different head sizes. Disposable hats are expensive and not always available but are another good option. Some hats also allow for beard coverage and are recommended for men. Head covers need to be changed each day. Re-usable ones need to be washed. Coverage of beards is also required.

Face masks

Face masks reduce the risk of cross-contamination to the operating field. The mouth and the nose must be completely covered—this is the only acceptable practice. Face masks are not effective after 5 minutes because they become permeable to air particles and secretion droplets from the staff member’s mouth, and should be changed frequently during the day. A fresh mask is to be used for each case. At tea and lunch breaks the mask must be removed and discarded into the correct receptacle and not left hanging around the neck. Do not touch the front of the face mask as it harbours micro-organisms. Face masks too, can be made of Jinja cotton. Disposable masks are available but are expensive. There are also masks available which have a plastic shield to protect the eyes. These cost more money but prevent the facility from having to buy separate goggles.

Masks only need to be worn when a procedure is taking place in that room. In all other areas the mask is not required.

Shoes

There are two types of shoes permitted. One is where normal outdoor (clean) shoes are covered with a protector, and the other is where specific OT shoes are changed into – these remain at the OT. Regardless of which type used, the shoes must be:

- flat – no platforms or high heels
- able to provide toe coverage and heel support
- made of a material that is less likely to be penetrated by a needle or blade
- made of a washable material
- Kept clean.

Note: in some countries, where roads and walkways are not paved, normal outdoor shoes may not be in an adequate condition to be covered and worn in the OT. Therefore a separate pair, specific for the OT may be best.

Eye protection

Eye protection is mandatory to prevent splash injury. Goggles or shields need to be readily available. These need to be worn when handling fluids or when there is a threat of exposure to fluids, when scrubbing, when lasers are being used in the OT and when working in the dirty sterilization room. Special laser goggles also need to be worn when working with lasers. Please see section 6 regarding laser goggle safety.

Gloves

A variety of gloves need to be available to accommodate all sizes and all needs. Depending on what is available, make sure the facility has:

- Sterile gloves for surgical and minor operative procedures.
- Non-sterile examination gloves for cleaning instruments and other non-sterile duties.
- Woollen (or other types of heat resistant) gloves to wear when removing hot items from the sterilizer – to prevent burn injuries.
- Thick rubber gloves – to assist the maintenance and cleaning team with non-medical related tasks.

Tips with gloves

- Always be mindful of surgeons who comment that the gloves are too slippery or thick. This might mean changing to a brand that has better grip.
- Always be mindful of staff and patient allergies to materials such as latex.
 - latex is a common material in gloves, in some parts of the world (despite being gradually phased out of use). If possible, try to purchase non-latex. If that is too expensive, then just have an emergency non-latex set available for the times when you do encounter someone with an allergy to latex.
- Sterile gloves containing powder also remain common in some countries (despite being phased out). If the facility is using powdered gloves, make sure that a step is included to wash off the powder once the gloves are on the hands. This prevents the introduction of the powder particles into the surgical site.
- Preferably all gloves (except woollen gloves and maintenance rubber gloves) are single-use only. If working in a rural setting

where there is a need to re-use, then please make sure they are changed after every patient and that all used gloves are placed in the glove cleaning and spinning machine. Consider the length of the glove when working in the sterilization room because water can easily enter a glove. Therefore, a wrist length glove may not be suitable. If possible, purchase gloves that reach mid-forearm length then this will protect the sterilization room nurses more.

Aprons

Aprons are needed when managing and handling body fluids and when working in areas such as the dirty sterilization room where there is a chance of being splashed. Aprons preferably need to cover the entire area of the body that may get wet – such as the chest, stomach and upper legs. The apron needs to be made of a waterproof material and needs to be changed daily (either disposable or re-usable are suitable).

Note: it is always a good idea to have an extra supply of all the above clothing to allow for staff, students and visitors.

Personal hygiene

Just as the OT needs to be scrupulously clean, so too must the staff be meticulous of their personal, hygiene needs. Staff need to wash their body every day. Hair and nails must be kept clean and short. If hair is worn long, it must be tucked neatly away under the appropriate headgear. No nail varnish or jewellery may be worn in the OT – with the exception of small hoop earrings that have a clasp.

Cuts and abrasions should be covered and reported to the person in charge who will decide what level of duties are appropriate for that person until they are healed. This is to prevent infection issues for both the patient and the staff member.

Cleaning the OT

It is extremely important to reduce the possibility of dust-borne particles entering the operating field and causing infection. OT cleaning is scheduled daily, weekly and monthly. While cleaning is in progress, stocking-up and stock rotation of sterilized drums etc. can also be carried out. It is useful to have a roster with specific cleaning duties allocated to staff (Photos 5.4 and 5.5). Cleaning regimes include:

Daily cleaning

Before surgery starts (or the evening before if the OT is temperature controlled)

- The OT must be damp dusted. A damp cloth with hot soapy water is used to wipe all surfaces, which are then dried with a dry cloth.
- The floor is cleaned by removing the excess dirt and dust and then mopping.
 - note: brooms and domestic vacuums are not the best for the OT as they disturb the dust and move it about the room too much. There are special hospital grade vacuums which may be available to you as an alternative. Otherwise, try and remove as much dirt as possible by mopping – this may mean repeat mopping if there is too much dirt.

In between each patient

- Damp wash-down of the bed and head rings, operating table and shared equipment between patients.
- Remove bin bags.

After surgery

- The OT must be cleaned. A cloth and hot soapy water is used to wash all the surfaces, including operating table tops and stools. Electrical cables are carefully cleaned with minimal usage of water to avoid possible electrocution hazards. Ideally a cloth with alcohol or other disinfectant should be used to wipe the cables, avoiding plugs and other areas of conductivity;
 - remember to clean the legs and wheels of trolleys and tables.
- The floor is washed with disinfectant.
- Hanging lights and other items on the ceiling are damp-dusted.
- When cleaning the facility, start in the OT, before moving to the scrub areas, anaesthetic and recovery rooms, and then the sterilizing area.
- The operating microscopes and operating lenses need to be cleaned after each theatre session. Do not clean microscope or lenses with soapy water as soap residue can damage the lens. Use a soft, non-abrasive cloth, for the lens and a cloth with alcohol or disinfectant, for the microscope, including handles.
- Hand towels, patient sheets and blankets in the theatre and toilet area must be changed after every use.
- The toilets and changing rooms are checked and cleaned throughout the day;
 - separate cleaning equipment must be kept for the toilets.
- Tea rooms and kitchens (and recovery area, if food given) need to be cleaned and all leftover food and crumbs removed so insects are not attracted to the area.
- The surfaces, floors, walls and ancillary rooms are all scrubbed with disinfectant.

Cleaning Tip: Try and have a mop for the clean rooms and OT, and a separate mop for the dirty areas. Change the water between each area too.

Weekly cleaning

- All articles are to be removed from the shelves, and the surfaces thoroughly cleaned with hot soapy water;
 - note: do not get sterile items wet as this will make the packaging permeable and no longer sterile.
- The floor is washed with disinfectant.
- Instrument trolleys including the wheels and the rungs are washed and dried.
- Bowls and gallipots are scrubbed.
- Windows (inside and outside) are cleaned.
- High surfaces, e.g. tops of cupboards and window sills are dusted whether they are used or not. This is to prevent the build-up of dust.

Cleaning Tip: Try and avoid using and storing aerosol cans in the OT as these are both flammable and releasing particles into the air.

Monthly cleaning

- Cupboards are moved away from the walls and areas behind and under the cupboards are cleaned. Tops of and inside cupboards, drawers and lockers are cleaned. All articles are removed from the shelves when doing so, to prevent damage. Expiry dates are checked and stock rotation implemented

(See section 9 for stock management).

- Trolleys, IV stands, stools, microscopes, etc. are all cleaned and oiled where necessary. Curtains, if used in recovery areas, must be washed at least every three months.

Cleaning materials

- mops and buckets
- hard scrubbing brush
- rubber pusher to remove excess water
- access to a tap
- disinfectant: check with the pharmacy department what is available and the best quality at an affordable price. It needs to be a germicidal agent that will kill a majority of bugs that can lie dormant on equipment
- absorbent cleaning cloths
- cleaning equipment must be in ample supply so that there is a set each for the theatre, toilet and the ancillary rooms. Sets should be stored separately
- Oil for oiling of wheels.

Other

- **Pest control** - liaise with the administrator and the maintenance team to schedule regular pest inspections and/or control measures to prevent pests. Any control measures need to be done when the OT is not used. For example, schedule this to take place a day before the weekend or a festival. This means the OT can settle and any issues rectified before it is needed again.
- **Air conditioning units and filters** – ensure they are checked and cleaned (+/- filters changed) as required.

Photos 5.4 and 5.5: Staff cleaning



Commissioning an OT

OTs that are brand new or have had maintenance (i.e. re-build or painting) need to be cleaned and checked before they can be used again. This requires a full clean of the facility – including ceilings, walls, and inside cupboards etc., and includes both management of the airflow and pest treatment.

After a full clean and preparation, the area needs to be microbiologically tested. How this occurs depends on the level of testing service offered by the local laboratory/pathology service. Ideally, agar plate testing needs to be performed at least twice before the OT is used. This needs to be performed before air-conditioning is turned on and then again 48 hours later – once the air conditioning has been allowed to run for 48 hours.

The tests are placed in no less than two spots within each room of the OT complex: the first on the outer perimeter of the room, and the second, preferably in the area where the patient's head will be positioned (or central area).

Ideally, two types of tests are performed. 1). Blood Agar – preferably human blood but if the laboratory service only has animal blood available, then that will have to be used instead, and 2). Dextrosa Sabouraud Testing.

The laboratory will be asked to incubate the agar plates for around 48-72 hours and then report on any noted growth. All reports need to be shared with the Medical Director and Infection Control Nurse so they can evaluate if it is safe to start using the OT and/or if further cleaning and testing is required.

Note: this process will vary around the world depending on the accessibility of laboratory services. Discuss the needs (and limitations) with the Medical Director, Infection Control Nurse and the Laboratory Staff to determine the best possible testing solution for the specific circumstances.

Surgical Hand Washing

There are two types of hand washing; normal and surgical. Normal has been covered in section 1 through mention of the 5 Stages of Hand Hygiene. This section will now discuss surgical hand washing - also commonly referred to as Scrubbing.

Scrubbing can be done via a traditional water method or by the newer waterless method. For the purpose of this text, the focus will be on the traditional water method as this remains the most common method in lower resource locations, and remains the most economically viable. Over time however, this may change, as prices for the waterless method become more affordable.

Scrubbing – traditional water method

Scrubbing

This is the term given to a stipulated procedure for thoroughly washing the hand and forearm before a sterile procedure occurs. Its objectives are:

- removal of dirt, skin oil and micro-organisms from the hands and forearms
- reduction of the microbial count as far as possible
- prevention of re-growth of micro-organisms for several hours
- Hat and mask at positioned (Photo 5.6).

Skin can never be sterile, only surgically clean.

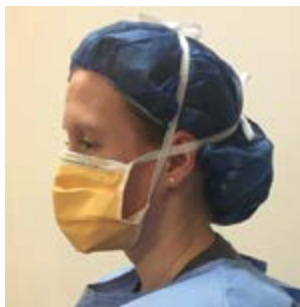

Photo 5.6: Demonstrates correct hat and mask wearing. Small stud earrings, with a secure clasp are acceptable.

Scrubbing needs to be performed by everyone involved in the surgery (i.e. surgeon, surgical assistant and scrub nurse) before each patient. While it is acknowledged that in some countries this does not happen, it is encouraged that steps towards a system of full scrubbing and gowning between each patient is considered. In the event that this is not possible, at least, the removal and change of gloves and the use of a waterless alcohol hand-wash, prior to re-gloving, should be encouraged.

Scrubbing is time based because the cleaning agent (i.e. betadine) needs to be in contact with the skin for a certain period of time. Times for the day are:

- 5 minutes for the first scrub of the day
- 3 minutes for all other in-between scrubs.

Within each of these periods, time is again divided to allow for hand rubbing and using scrub brushes and nail brushes.

Around the world however, the 5 minute wash happens very differently. For example, some nurses in some countries may perform a 2 stages in 5 minutes while others perform a 3 stages in 5 minutes.

Either can be used, as long as there is consistency across the facility and staff are performing the scrub as per their policy.

For the 3 minute 'in-between-patient-scrubs' the practice varies again, for example:

Two Stage - Country A	Three Stage - Country B
1 minute rub then rinse	1 minute rub then rinse
4 minute brush and nail and then rinse	2-3 minute brush and nail then rinse
	1 minute rub then rinse

Table 5.1: Comparison of a two and three stage hand wash

Either can be used, as long as there is consistency across the facility and staff are performing the scrub as per their policy.

For the 3 minute 'in-between-patient-scrubs' the practice varies again, for example:

Country 1	Country 2
1 minute wash and rinse	1 minute wash and rinse
2 minutes brush and nail and the rinse	2 minutes wash and rinse

Table 5.2: Comparison of 3 minute hand wash

Again, either is acceptable as long as policy and practice are consistent. Of note: some countries have moved away from using the brush during the 3 minute (between patient) wash in order to reduce the 'sluthing' of the skin which can be quite harsh on the hands.

Scrub brushes: scrub brushes are effective, but it is important to keep in mind how often they are used, and their firmness, because, if the brush it too hard or it is used on the forearms, it can cause a lot of pain. Long term – it can also damage the skin, cause redness and actually release dead skin. Therefore when purchasing brushes, consider purchasing ones that are softer rather than too hard.

Use one brush per scrub member per wash – then it is discarded or sent to be re-processed.

If re-processing brushes, check that they are made of a material that can withstand sterilization.

Scrubbing techniques

Moving along the arm

Regardless of doing a 2 stage or a 3 stage wash, or using a brush or not, be mindful of what part of the arm is being cleaned in each step. For the first step, wash up to and beyond the elbow. For the follow-on washes, wash below the elbow – to the forearm. This means that cleaned hands are not going to touch parts of your body that have not been cleaned.

The procedure (which can be adapted to either method of 5 minute and 3 minute washes).

Aim

- to minimise the risk of cross-infection
- to create a sterile field.

Scrubbing solutions

Anti-microbial soap or scrub solutions should:

- have effective rapid action on skin organisms
- be a broad-spectrum anti-microbial agent
- be gentle on the skin
- common products such as povidone iodine 5% are popular and easily available scrub solutions. Pharmacists will provide details
- note: be mindful of staff allergies and provide alternatives if needed.

Check list—scrubbing preparation

- The scrub nurse must be in good health, and not suffering from any upper respiratory tract infection nor have any open cuts or grazes.
- The scrub nurse must be confident and competent to scrub and assist during the operation.
- The hat and mask must be comfortable and worn correctly.
- Expose arms past the elbow (ideally scrub tops will be t-shirt length).
- Remove all jewellery (watches, bracelets, rings) and nail varnish. Ensure finger nails are clean and cut short;
 - for jewellery that cannot physically be removed or must not be removed for cultural/religious reasons, then discussion is needed with the OT manager. Materials that can be cleaned, i.e. gold rings or jade bracelets can be washed over, and washed under during the scrub, however jewellery made of cotton (i.e. friendship bracelets) cannot and therefore that nurse may not be assigned as the scrub nurse.
- Make sure the OT is set up prior to scrubbing. This means all equipment, instruments and consumables are ready – and that the circulating nurse is ready.
- Check all required scrub materials are available, e.g. water, nail brush, scrub solution, sterile gowns, hats, masks and gloves before scrubbing commences;
 - preferably scrub solution is liquid based. Only in the event that this is not available should soap bars be used.

Remember: if anything is touched during the scrub, e.g. the wall or another person, then the whole procedure must be started again. It is important to be honest in this regard otherwise the patient could suffer severe consequences. Each complex should have a standard scrubbing policy for all surgical staff.

How to move the body when washing

It is important that the body movement is restricted in order to prevent contamination of the hands and arms during and after the scrub. This is also a good principle to use when gowned and gloved too. The principles are:

- hands and elbows away from the body
- hands at chest height

- if not doing anything, hold/place your hands together
- when washing, start from the fingers and move downwards towards your elbows
- when rinsing, place hands and arms on an angle and rinse from hand to elbow – if a bit is missed, start at the hand again and move down to the elbow
- if needed, twist the wrist so that the forearm moves – thus allowing the water to rinse all parts of the arm.

Scrubbing procedure—this takes 5 minutes (the information below can be adjusted to suit all methods)

1st Minute

- Before wetting hands, open nail brush ready for use (if using).
- Turn on water and with elbows pointing downward, wet hands and forearms.
- Depress the soap dispenser with elbow or pick up the soap bar and work up lather on hands and forearms to 1 inch above the elbows.
- While soap is in contact with skin on arms and hands, gently clean nails under slow running water.
- Once nails are cleaned wash soap from hands and arms allowing water to run from hands to elbows.

2nd - 4th Minutes

- Apply soap again to hands and arms up to 1 inch above elbows.
- Wash hands paying close attention to finger tips, in between fingers and back of hand.
- Using a circular motion wash up to elbows before rinsing off again, being careful to let water run from hands to elbows.
- If using a soap bar, follow the procedure as given but do not put down the soap until the whole scrubbing procedure is completed.

5th Minute (if doing the 3 stage method)

- Lather up the hands and forearms, again stopping just above the wrist.
- Pay attention to cleaning hands and in between fingers.
- Rinse off after one minute.

After the 5 minutes

- Drip off excess water into the sink before walking away and into the OT. This is to prevent water landing on the floor and creating a slip hazard.
- Hold hands gently together, away from the body and at chest height – keep elbows away from the body too. Retain this stance when walking into the OT.
- Do not touch the OT door while walking in. Be mindful of other people using the door to prevent injury or contamination to your hands and arms.

Note: it is not necessary to leave the taps running all the time. The circulating nurse can turn the water on and off as required or if there are long handle taps then these can be turned off using the elbows during the 5 minute scrub. Where able, install a sensor or foot-controlled tap so it can be turned off without using any hands.

If there is no running water available, the circulating nurse should pour clean water from a jug, pouring from fingertips to elbow, as in the case of using a tap.

Drying hands (when inside the OT)

Imagine that the towel is divided into 4 squares or quarters Diagram 5.2):

- Without contaminating self or without touching the drape, take a corner of the towel with one hand and step away from the table. Let the towel unravel (unfold).
- The drying principles are:
 - start at the hand and move down to the elbows
 - dry one hand and arm first and then the other hand and arm
 - never re-use a part of the towel.
- With the 1st quarter, dry the fingertips, the back and the palm of the left hand in a circular motion.
- With the 2nd quarter, start at the wrist and again with a circular motion dry up to the elbow of the left arm. When the elbows are reached, the towel should be turned to the 3rd quarter.
- With the 3rd quarter, dry the fingertips, back and palm of the right hand in a circular motion.
- With the 4th quarter, start at the wrist, and again with a circular motion dry up to the elbow of the right arm. When the elbow is reached, the towel should be discarded.
- Never go over an area that has already been dried.
- If the hands still feel damp, another sterile hand towel should be provided and the above procedure repeated.
- Drop the towel into the waste or linen bin without contaminating self.

Tips: When making re-usable hand towels, choose a long lasting towelling material. Select a size of cloth which will dry the hands and arms satisfactorily. Make sure it is made of a low-lint material. The sterile gown and sterile hand towel should be laid out on a sterile trolley for the scrubbed person.

Diagram 5.2: Towel quarters

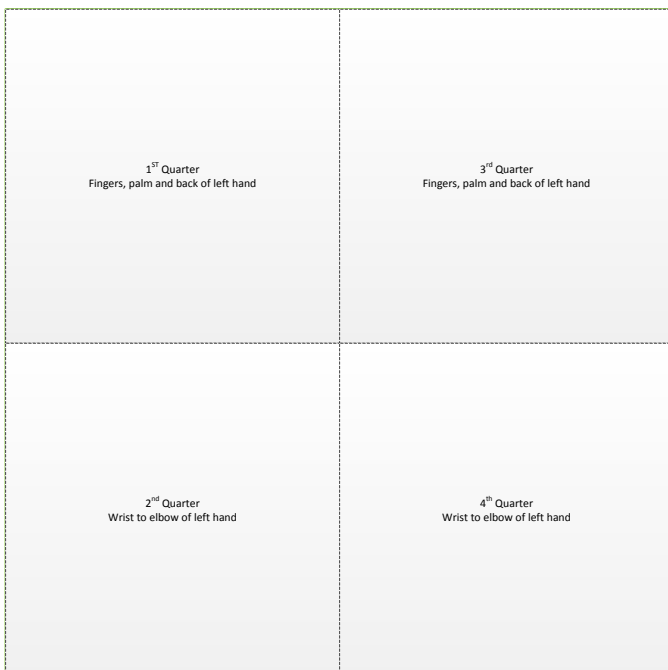

Packing re-usable gown bundles

If the facility re-uses gowns, then it is important that the OT staffs are familiar with the folding and packing of clean gowns and drapes into bundles ready to be sterilized. The procedure includes checking the integrity of the gown (and towel). Look for:

- Tape or other items that might be stuck to the material. It is important to remove these first otherwise they melt into the material once sterilized.
- Breaks in the material (i.e. holes) because these items need to be able to provide full cover. Items with holes need to be removed from service and either fixed or replaced.

Gowning

Once the hands and arms have been dried, the scrub staff must put on (don) a gown, and then gloves.

While the whole gown is sterile, the sections 'considered' sterile, once worn, are from fingertips to elbows, and clavicles to waist. The scrubbed and gowned person is not considered sterile at the rear, or below waist level. The scrubbed staff must:

- ensure hands and arms are dry
- cover any small skin breaks with a sterile waterproof cover (band aid or tegaderm). This is changed after every wash and every patient;
 - the sterile band aid/tegaderm is placed onto the prepping trolley for the scrub person to pick up without touching anything else
- without contaminating self, picks up one gown and step away from the trolley
- looks around first to make they will not hit anything (contaminate self) and then proceed with unravelling the gown. To do this:
 - hold the gown at chest height – away from the body
 - find the arm holes and grip the gown at that point
 - allow the gown to unravel (unfold) without it touching the floor
 - place one hand into an arm hole at a time, without contaminating. If pushing arms through the gown, stretch them out to either side, but do not stretch them up too high or down too low. This is to prevent contamination
 - do one arm at a time
- once the arms are through the gown, ask the circulating nurse to take the back of the gown and tie it up at the back. Then, commence putting the gloves on (gloving will be explained shortly).

This general principle can be applied to disposable wrap-around gowns too.

See photos 5.7 – 5.13.

Circulating nurse - tying a gown

Disposable and re-usable gowns have different tying requirements. Familiarity with the type being used is required. For this text, tying a re-usable gown will be discussed.

- The circulating nurse stands behind the scrubbed person and takes the ties to secure the gown comfortably.
- The scrubbed person leans slightly forward to allow the front ties to fall away from the sterile front of the gown. This is to avoid contaminating the gown
 - they hold out the tie, from the base

- The circulating nurse or assistant then picks up the ties by the tips only and takes them to the back to be tied in a bow.

Removing gloves and gowns at the end of the case

- A circulating nurse unties and pulls the gown from the scrubbed person's shoulders. The gown should be removed so that the outside of the gown is turned inside-out. The gown is immediately placed in the used-linen carrier.
- One glove is then wrapped inside the other as they are removed so that the outside is not exposed. The gloves are then discarded.
- Used gloves, gowns and drapes must not be thrown onto the floor or left lying about the OT. They must be removed in designated used-linen carriers (re-usable) or waste bins (single-use).

Removing contaminated gowns during the procedure

- The scrubbed person steps away from the sterile field- preferably they stand up.
- The circulator unties the gown and asks the scrub person to lean forward slightly. This exposes the inner surface of the gown.
- The circulator stands in front of the scrubbed person and holds onto the inner surface and pulls down and away until the gown and gloves are removed. The gloves can be removed in a similar manner as outlined above without contamination.
- A new gown and glove set is opened up.

Technique: Prior to gowning and gloving

Photo 5.7



Step 1: After completing a surgical scrub, cover any wounds with sterile water proof bandaid/tegaderm. Then, the gowning and gloving may occur.

Technique: removing a gown at the end of the case

Photo 5.8-5.13

Step 1: After the circulating nurse has untied the back, tug at the main part of the gown and pull it down towards the arms

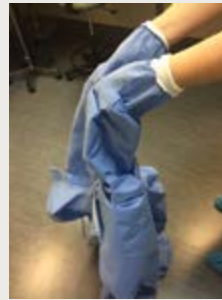

Step 2: Allow the gown to fall off the arms but keep the gloves on. Ensure the bulk of the gown is in the linen basket or waste bin to prevent it dropping on the floor.

Step 3: Tuck fingers into the cuff and glove to remove inside-out. This prevents contaminated outer aspects of the glove and gown touching the staff member.

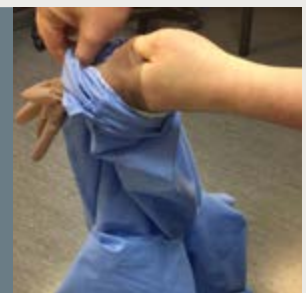
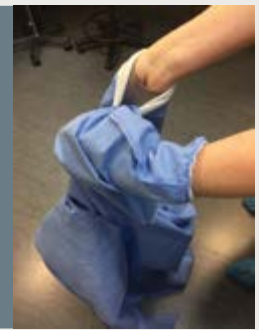

Gloving

There are two methods of gloving.

1. closed method (Photos 5.14 – 5.19)
2. open method.

The closed method should be practised routinely.

Closed method

The hands should not emerge from the sleeves of the gown until the hands are gloved. This minimises the contamination of the gloves which are handled only through the material of the gown sleeves.

Open method

The hands are pushed through the sleeves and the scrubbed person touches the inside of the sterile glove only.

If powdered gloves are used, all gloved hands must be washed in sterile water or rinsed with alcohol solution before commencing the operation, because glove powder may contribute to Toxic Anterior Segment Syndrome (TASS) and endophthalmitis. The water used must be discarded and must not be placed on the sterile field or used for rinsing instruments.

Gloves are often difficult to put on, and, if additional glove powder is used, it must be washed off with sterile water before the instruments and sterile field are approached.

Once the glove is on, the scrubbed person can make themselves comfortable by making sure the tip of the glove is at the tip of the fingers, and by tugging gently on the gowns wrist-band to pull up the materials.

Gloving the surgeon

While not routine around the world, some surgeons may ask the scrub nurse to assist them with gloving. In this instance, the surgeon, once gowned, exposes their hands from inside the glove and places them in a downward position. The scrub nurse picks-up the gloves, one at a time, and opens them up to create an entry point. The nurse tucks their own hands under the lip of the glove to prevent being touched by the surgeon's hand.

Together, the gloves are positioned. The scrub nurse pushes the gloves upward while the surgeon pushes their hand down and into the glove. Once on, the nurse can release the glove. The surgeon can then manoeuvre the glove into a comfortable position.

Removing contaminated gloves during the procedure

- The scrubbed person can pinch a section of the glove, over their thumb so that a small section of the inner surface is exposed.
- The scrubbed person places their contaminated hand outwards so the circulating nurse can get close.
- The circulating nurse takes hold of the exposed inner surface and pulls down until the glove is off
- A new set of gloves is then opened up onto the sterile field ready to be reapplied.

See photos 5.20 – 5.22

Technique: Closed gloved method

Photos 5.14 - 5.19



Step 1: Keep hands tucked inside the gown at all times. Feel, through the gown, and open-up the glove pack. Pick one glove up through the gown material.



Step 2: Place the glove on the corresponding hand. Position the hand flat with the palm facing up. The glove is placed with the glove-thumb down.



Step 3: With hands still inside the glove, and using fingers, pinch the glove and pull it up and over the hand.



Step 4: Maneuvers the glove onto the fingers and start pushing the hand into the glove.



Step 5: Make the glove comfortable by gently tugging at the cuff. This will remove glove wrinkles and bulk around the wrist.



Step 6: Remove any remaining gaps from the finger tips to make the glove fit smoothly.

Technique: Removing contaminated gloves during a procedure

Photos 5.20 - 5.22



Step 1: Pinch the cuff (opening) outside of the contaminated glove with the other hand.



Step 2: Peel the glove back and over the thumb to expose the inside of the glove.



Step 3: Allow the circulating nurse to touch ONLY the inside-part of the glove – ensuring they do not touch the gown. Ask them to pull the glove down and off the hand.

Drapes, Patient Preparation and the Sterile Field

The sterile drapes provide a sterile field on which to place the sterile surgical instruments. All items that come into contact with the drape must be sterile. The sterile field is created when the drape is placed over the patient's face. It needs to extend to below the level of the operating table on all sides, and to cover the patient's abdomen. Although the site of operation (the eye) is small, the necessary sterile field is substantially larger.

The immediate area around the eye needs to have double thickness draping for moisture absorbency. The hole in the drape should allow adequate access but minimum exposure to the eye and needs to be about 5 cm square.

The drape should be folded and packed in such a way that, when it is to be positioned, it opens out easily. It must not be shaken. Once the patient is draped, only then should the trolley be placed in position and the surgery commenced.

It is also advisable to have paediatric and appropriate oculoplastic drapes available.

Draping is performed after the SSS check and the surgical site has been prepped.

Drape material

Drapes are made from cloth, paper or plastic. Regardless of the material used, it must prevent the transfer of micro-organisms. The material must be lint-free because lint is made of small particles of soft cloth which can be deposited in the eye and cause fibrosis.

The material needs to be pliable enough to be moulded around the contours of the patient's face, so that the area is well protected and the drape can be secured. In some lower resource locations, cloth is the best and most practical choice. Jinja cotton tolerates frequent washing and sterilization. When buying cloth, the heavier density weave should be obtained as this will prolong the life of the drape and also give a better protective barrier. A denser weave creates less lint. Drill, denim and canvas, however, do not allow for good penetration of steam and should therefore not be used for drapes.

The colour of the drape material is very important. Most ophthalmic sutures are blue or black and it is easier for the surgeon to work on a light coloured drape, e.g. light green or blue, which will show up fine sutures.

For intraocular surgeries, a plastic, sticky, disposable drape can also be purchased. The drape sticks to the skin around the eye, and the surgeon cuts a hole in the plastic to expose the eye. These are useful to hold eye lashes back and prevent fluid from dripping down the patient's neck.

Disposable drapes

Disposable drapes are now routinely available in many countries. The drapes can also be ordered to the dimensions required. They have the advantage of being 100% water repellent and lint free. Buying in bulk can also reduce the price.

It is not practical to re-sterilize disposable drapes as the paper material can be weakened and therefore is no longer water repellent. A special sterile plastic bag attached to the side of some drapes can also help to collect fluid from the sterile field.

Some manufacturers produce pre-packed sterile drapes alongside common consumable items, though these packs can be expensive.

Drape dimensions- at least, should be:

Trolley drapes for two different trolley sizes

- Trolley size 46 × 46 cm, use a drape size of 56 × 56 cm
- Trolley size 90 × 90 cm, use a drape size of 110 × 110 cm.

Patient drapes (Diagram 5.3)

- body drape size 120 × 220 cm
- eye drapes size 30 × 30 cm.

Diagram 5.3: Patient Drape

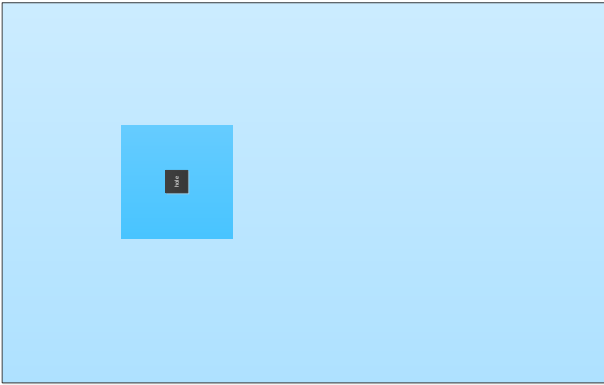

Maintaining the sterile field

It is the responsibility of the scrub nurse and surgeon (and assistant) to ensure that the sterile field is maintained during surgery. It is also necessary, if the patient is under local anaesthesia, to inform them not to touch the drapes or raise their hands (for sterility, surgical safety and to protect the instruments from damage). Photo 5.23 and 5.24 indicates the sterile area during the procedure.



Photo 5.23: Indicates sterile area (chest and elbow to wrist). When not required to do anything, ensure hands rest within this zone.

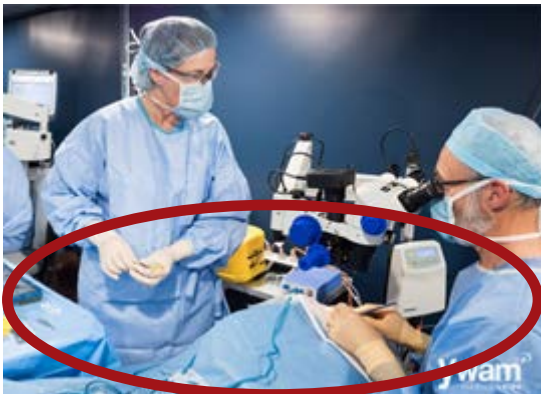

Photo 5.24: Circle indicates sterile field.

Preparation of the OT Trolley

Aims

- create a sterile field for the sterile drapes and instruments
- prevent contamination from trolley to instruments
- prevent contamination from the previous operation.

Before opening sterile items, check that the external chemical indicators have changed colour to indicate the items have been sterilized, and ensure the package integrity has not been compromised.

The drape

When making trolley drapes, ensure that they are large enough to allow 10 cm to hang over all sides and allow for shrinkage in the first few washes. It is advisable to wash the material before it is made up.

Reusable drapes can come in either a sterile metal drum or in a linen bundle.

Sterile drums

- Use Cheatle's forceps to remove the trolley drapes from the sterile drum or packs, making sure that the outside of the drum are not touched.
- Hold the corners of the drape firmly, stand back from the trolley and allow the drape to fall open.
- Lay the drape on the trolley from front to back, and ensure that the trolley top is completely covered.

Linen bundles

- Bundles are usually wrapped with 4 folds.
- Open the outer - first fold - away from self.
- Open the side (second and third) folds to each side.
- Before opening the final fold, take a step away from the trolley. This will prevent contaminating the inside of the bundle when unfolding the final fold.
- The trolley is now sterile, only the scrub nurse can touch it.

Remember!

Do

- check the chemical indicators have changed colour – i.e. the items are sterile
- check the integrity – if there is a hole in the drape, get rid of it and get another one
- clean the trolley between operations
- change the drape after each operation
- remove all unused items from each trolley and, where possible, re-sterilize
- make sure the trolley surface is dry before putting on the drape
- ensure the drape is an adequate size to cover the surface
- keep all sterile trolleys together
- clean the trolleys thoroughly
- be honest about sterility.

Do not

- take short cuts
- contaminate by leaning over or passing between sterile trolleys
- place the trolleys under dusty ceiling items (i.e. television monitors)
- pass items to other trolleys
- place wet items on the trolley drape
- touch the trolley with the Cheatle's forceps
- back-up to a sterile trolley
- put hands below waist level or surface of the trolley
- use lower shelf of trolley as part of sterile field.

Preparing the patient

To prevent micro-organisms from entering the wound, it is important to clean the patient's face before surgery. Skin preparations vary but, principally, they must reduce the number of micro-organisms on the skin.

The day before surgery

- Ask the patient to wash their face and hair in warm soapy water and remove all make-up.
- If the surgeon has asked the patient to take any pre-operative eye drops then check that they have been started.
- Ask the patient to wear clean clothes;
 - in facilities where the patient wears their own clothes, it is important that they do not wear their best clothes to the hospital. This is because they may get wet from fluids such as betadine. Additionally, betadine can stain some clothes
 - recommend clothes with loose collars to reduce constriction around the neck. This prevents the patient from having to push their face through tight clothing, post-operatively.
- Recommend that all removable jewellery is left at home.

On the day of surgery

- The patient's hair should be tied back or put into a theatre cap. Hairpieces must be removed.
- If the patient has any signs of septic spots, facial infections or a discharging eye, the doctor needs to be informed. The operation may be postponed.
- The face is cleaned and make up removed.
- Contact lenses are removed.

Key principles

- Check the prepping concentration (as per Standing Orders), prior to administration of any preparation solution.
- Check the patient has no allergies to the solution.
- The patient's face has been washed.
- Always ensure the prep has dried before placing drapes
- Ensure the drape margins are within the prepped area – i.e. no un-prepped skin is exposed.

Surgery prepping

Intraocular surgeries

- Pre-operatively, administer Povidine Iodine eye drops (0.5-1.0%) to the eye and surrounding lid, lash and skin (check standing orders).
- A similar wash is performed prior to draping in the OT.

Extraocular

- For lid surgeries, clean the facial area marked by the surgeon.
- generally prep is not placed onto the eye as this will sting (unless a numbing eye drop has been pre-administered).
- Graft sites on another body area – e.g. behind the ear, also need to be prepped carefully.

Note: in the past it has been routine to cut eyelashes, but this is not practised these days. The lashes tend to re-grow irregularly and stronger. This can predispose to trichiasis. Therefore, most hospitals and surgeons no longer advocate for lash trimming.

Prepping and draping a general anaesthetic patient

Check with the surgeon and anaesthetist to determine the pre-site and the drape positioning. This needs to be planned to ensure maximum exposure to the surgical site without compromising the airway or access for the anaesthetist.

Aseptic (non-touch) technique

The use of aseptic technique is essential for preventing the spread of infections. This is a fundamental requirement of all staff working in any type of OT, anywhere in the world – and ophthalmology is no exception.

Practice

- Performing the technique effectively takes time and practice for both scrub nurse and surgeon.

Principles

- neither the scrub nurse nor the surgeon touches the working part of the instrument at any point in the operation. The working part of the instrument is the part which actually touches or enters the eye
- the eye itself is never touched with the fingers, only with an instrument
- keep all sharps in one location on the sterile scrub trolley to minimise the risk of injury.

Universal precautions

A long time ago, it was assumed that special protective precautions were only needed for people with a known infection, i.e. AIDS. These days, however, the concept has changed to what is now termed Universal Precautions (UP). This means that every patient is treated the same, and the same level of precautions are applied. It is not really known if a patient has or has not got an infection unless they are tested for all possible infections. As it is not practical to test everyone for everything, instead, a preventative strategy is applied. These include:

- Washing hands – see the 5 stages of hand hygiene in section 1.
- Wearing Protective Equipment – i.e. masks, goggles, and aprons.
- Wearing gloves when scrubbed or handling body fluids, dirty instruments or waste materials.
- Using an aseptic technique when scrubbed to reduce/eliminate potential issues.

Management of an infected patient in the OT

Safe management of a patient with a known infection, e.g. one who has endophthalmitis and/or a hypopyon is important. The patient should be made to feel as comfortable as possible and informed of the additional precautions that are being taken to reduce the risk of cross-infection.

To provide effective care:

- Always inform them of safety precaution measures.
- Ensure kindness and support is always provided.
- place the patient last on the surgical list for the day to prevent cross-contamination to following patients – unless it is an emergency under special arrangement/policy.
- Limit the number of staff in the OT.

- Remove all unnecessary items of equipment from the OT.
- Practice Universal Precautions;
 - wear Personal Protective Equipment at all times e.g. gloves, mask, and eye protection.
- Double glove if scrubbing, giving anaesthetic or cleaning instruments.
- Discard all disposable items on the trolley at the end of the operation.
- Minimise the amount of movement in the OT.
- Blood and body fluids must be handled safely.
- Eye dressings should be applied in the OT and the patient taken straight back to the ward (if an in-patient).
- Specimens should be clearly marked according to the hospital policy and wrapped in a plastic bag. The specimen form should also be labelled;
 - an outside bag must be provided to protect the handlers.
- If possible a separate set of instruments should be set aside for use with infected cases, and be clearly marked. e.g. 'infected cataract' for cataract set.
- Complete a full clean of the OT.

Cleaning instruments used on an infected patient

If a facility operates to best-practice and uses safe disinfectant agents and appropriate washing and rinsing techniques, as suggested in section 7, then technically, instruments used on infected patients can be cleaned in the same routine manner.

If practice is not to standard, as recommended in section 7, then instruments may need to be soaked longer, or alternative cleaning products used or instruments may need to be disposed of (which may be expensive). Check with the Director of Nursing if no routine policy is in place.

Removal of used or contaminated linen

It would be better to meet with the laundry manager and ask them how they would like the 'used and contaminated' linen handled. For example, some facilities have different coloured linen bags for contaminated linen, while others may ask they be placed in a plastic bag which then goes into the normal used linen area. It is always best to ask them. Regardless, the used linen should be removed from the OT immediately.

Removal of waste/rubbish used on infected patients

Waste is routinely removed from the OT after each patient. Ideally, general waste and contaminated waste are divided. Contaminated waste is removed from the OT immediately.

Documentation

All staff (including the anaesthetists and surgeons) are responsible for completing their paperwork before the patient leaves the OT. It is also important that the chart leaves the OT with the patient. This is to prevent a chart mix-up when there is a new patient in the room, and ensures the recovery staff have complete access to all the documentation.

Some OTs have a log book, primarily paper-based, but this is slowly changing to electronic-based. The log provides a record of what procedures (by whom and to whom) took place in that room.

Other documents routinely found in each OT include:

- logs (i.e. pathology specimen, cancellation and prostheses logs (e.g. IOL)
- clinical indicator capturing logs (this is a quality tool which

will be discuss in section 9)

- spare incident forms (discuss in section 9)
- ordering forms
- spare copies of key forms, i.e. SSS check sheets – if not routinely placed in the patient's chart by the administration team.

Safe Site Surgery Checklist

Please see section 1 with regard to Safe Site Surgery (SSS) checking systems. SSS is the responsibility of the entire OT team. It is mandatory that this be performed for all patients.

Techniques for Passing Items to the Surgeon

The choice of technique is determined by:

- surgeon preference
- if the surgeon is right or left handed
- the positioning of the scrub nurse to the surgeon (i.e. is the scrub nurse at the surgeon's left or right side).

Key tips include

1. Ensure safety always comes first – prevent harm to self, surgeon and the patient.
2. Pass instruments directly into the surgeon's hand to prevent them from having to change their focus from the operative site.
3. Avoid passing directly over the surgical area or the patient's face – this is to prevent distraction and injury, in the event that the item is accidentally dropped.
4. Pass the instrument in a manner that will allow the surgeon to instantly use it without having to re-adjust. This means passing the handle directly into the palm of their hands or placing their fingers/thumbs directly onto the grips (i.e. the finger-holes of scissors). This can take some practice but is a useful skill.
5. Try and use two hands at the same time (instrument and procedure depending). One hand is to remove the current instrument from the surgeon, while the other is to hand them their next instrument:
 - a. this will require knowledge of the procedure in order to anticipate what is required next.
 - b. Alternatively - ask the surgeon to place the sharp item on a cleared area of the trolley. Once the surgeon returns to the surgery – and there is no chance of them knocking, touch only the handle and pick it up and place it safely into the sharp container, out of the way.
7. When handing a solution to the surgeon (i.e. a drug or viscoelastic) always say what it is – including any concentration rates. This gives the surgeon a final chance, prior to administration, to confirm they have what they need:
 - a. always label syringes and solutions to ensure there is no mix-up. It is possible to purchase pre-made sterile stickers which the scrub nurse simply sticks onto the syringe. An alternative method is implementing a routine practice whereby sterile steri-strips are written on with a surgical marking pen

- b. if neither are available, a routine system needs to be developed between the nurses and surgeons, to ensure all syringes and solutions are confirmed
8. When handing anything electronic or another type of powered item, that can be adjusted, i.e. laser, cryoprobe, and diathermy or phaco-hand piece, always tell the surgeon of the settings. Also, give advance notice of any settings change and/or if items, such as irrigating solution, need to be swapped over or changed. This is to prevent issues from occurring or delays to the procedure.

See photos 5.25 – 5.27



Photo 5.27 – 5.28
Indicates a double move of simultaneously removing and replacing an instrument. This is tricky to master and requires quick hand movements to prevent blocking the space for the surgeon to move.



Photo 5.25: Indicates passing an instrument by the handle – ensuring it is ready to use. Try and pass away from the operative area to prevent blocking the view for the surgeon.

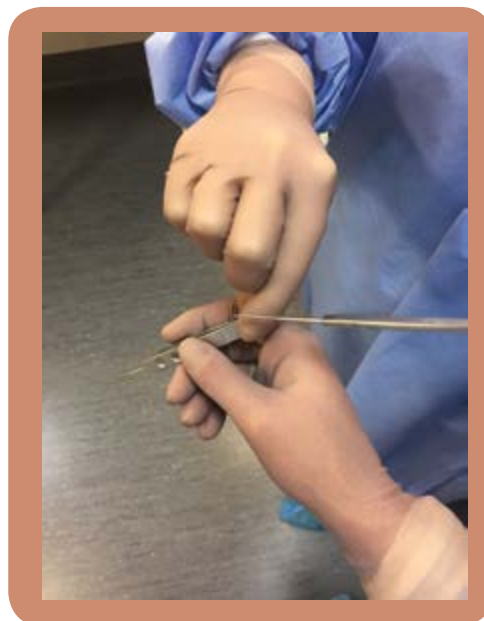

Photo 5.26: Pass scissors into the correct fingers if possible. This is tricky to master. Be careful not to block the view if passing from under the hand.

Care of Specimens and Tissue for Transplantation

Specimens

- Specimens can be fresh or in formalin.
- They need to be logged and labelled before they leave the OT – ask the surgeon how they should be named, and if fresh or formalin storage is needed.
- Scrub and circulating nurses need to be mindful of cross-contamination when transferring from the sterile field to the transport container. Personal Protective Equipment (PPE) is needed.
- Specimen collection is tracked during the Sign-Out part of the SSS checking process.
- Formalin specimens do not always need to be urgently rushed to the pathologist while fresh ones do need to be sent as soon as possible, as the fresh ones do not have any preservatives.
- Make sure any pathology request slips are signed by the surgeon and are transferred with the specimen.
- Log the specimens in the pathology log book.

Tissue for transplantation

While a prosthesis is generally man-made (i.e. a manufactured IOL), transplant material tends to come from humans (note: there are a few exceptions of animal-based products but we will not discuss those in this section). Familiar types include cornea, sclera, and amnion and stem cell materials.

Donation process

Human eye tissue is generally obtained after confirmation of consent from the deceased (dead) person's family. The eye bank coordinator seeks information about the deceased person's ocular, medical and social history. Collectively, this provides the coordinator with enough information to determine if the donor's eye tissue is suitable for transplantation. Thereafter, the coordinator will recover (remove) the eyes within 24 hours of death. The eyes are then taken to the eye bank where the tissue is separated and prepared. The tissue is tested for its integrity and suitability. Additionally, a blood sample will be taken to test for diseases. Tissue that passes all the tests is prepared in a preservation medium until ready for surgery. Generally, the surgeon will order the tissue directly from the eye bank and ask it to be delivered to the OT on the day the surgeon has scheduled the patient for surgery.

Table 5.3: Corneal tissue preservation and storage

Appearance	Technical preservation name	Where to store it	How to store it	When to use it by
Warm – pink coloured liquid	Normothermic	Somewhere warm at body temperature	Secure cupboard in normal air conditioned space. Not too hot and not too cold.	As per the expiry date
Cold – pink coloured liquid	Hypothermic	Fridge	Between 0-10 degrees	As per the expiry date
Room temperature – clear-viscous-brown colour	Glycerin	Room temperature	Secure cupboard in normal air conditioned space. Not too hot and not too cold.	As per the expiry date

Common Ocular Tissue Types

Cornea

Corneal tissue (Photo 5.29-5.30) is used for all types of corneal surgeries (see section 2) and can be preserved in several ways (cold, warm or glycerin). They can be kept in storage for a certain period of time. It is important for the nurse/technician to know how tissue is preserved, how to store it, and when to use it by. It is always best to ask the eye bank and follow their instructions – but a quick guide is outlined in Table 5.3.

Sclera

Sclera (Photo 5.31) is used to provide 'patch-grafting' to an eye that might have a melanoma/burn or to cover a valve implanted during glaucoma (trabeculectomy) surgery. A small piece of sclera is provided and it can be stored in two ways.



Photo 5.29 – 5.30 demonstrate two different storage mediums for corneal tissue. 5.29 is normothermic and 5.30 is hypothermic. There are other methods and other storage container systems available. 5.30 also demonstrates the passing technique of the circulating nurse when transferring the tissue into a secure container on the sterile field.

Table 5.4: Scleral tissue preservation and storage

Appearance	Technical preservation name	Where to store it	How to store it	When to use it by
In a clear liquid	Alcohol (+/- gentamycin)	Room temperature	Secure cupboard in normal air conditioned space. Not too hot and not too cold.	As per the expiry date
In a container without fluid	De-hydrated	Room temperature	Secure cupboard in normal air conditioned space. Not too hot and not too cold.	As per the expiry date



Photo 5.31: Sclera

Accepting tissue

Staff (or the surgeon) who receive the tissue from the eye bank need to check the integrity and suitability of the tissue. This includes checking that the:

- Tissue has been transported correctly (i.e. to ensure the temperatures are stable).
- Label and paperwork match (i.e. code number and that the information and donor history outlined on the eye bank paperwork matches the bottle/container) (Figure 5.4 and 5.5). The surgeon also needs to check the details and ensure the tissue is suitable for that particular patient.
- Bottle/container is intact. This means the bottle and seal has not been broken.
- Tissue has not expired past its recommended date of use.

DO NOT use the tissue if the bottle/container has been incorrectly stored in transport, opened or damaged, the paperwork does not match the bottle/container, or if there is no paperwork provided or if the tissue has expired.

Tissue should not be cut and divided by the surgeon. One tissue is issued by the eye bank for one patient only. This ensures sterility and accountability is maintained.

Note: The expiration checks are important because the tissue WILL deteriorate and/or there may be the possibility of introducing bacteria to the patient. This will, in turn, reduce the success of the graft post-operatively. Therefore, all expired tissue MUST be returned to the eye bank and must not be transplanted.

Documentation

Place details of the tissue into the surgical notes. This can go in the prosthetic section on both the nurse and surgeon pages and within any OT log books. If a sticky label is provided, then use that. If not, then hand-write the label code number and expiration date.

Safety checks

Remember to check the tissue before the surgery lists start. It will be too late once the patient is in the OT, and include a tissue check during Sign-In and Time-Out, to ensure the tissue is ready and appropriate.

For further information

1. Eye Bank Association of Australia and New Zealand. (2016). National Guidelines: A Resource for Australian Hospitals, Operating Theatres and Day Surgery Staff Regarding the Care and Handling of Human Tissue for Ocular Transplantation. Melbourne. <http://www.ebaanz.org/wp-content/uploads/2016/03/EBAANZ-NATIONAL-GUIDELINES-2016-For-the-care-and-handling-of-HTO-FINAL.pdf>

Figure 5.4 and 5.5: Examples of tissue documentation and labelling.

THE EYE—BANK FOR SIGHT RESTORATION CORNEA in Optisol GS
 120 Wall Street, New York, NY 10005 (212) 742-9000 ID# 0321-15
 W3993 15 000321 Expiration Date 2015-03-12
 Product V0004000 Date/Time of Death 2015-02-25 17:16
 Date/Time of Preser. 2015-02-26 01:48
 Single Patient Use Only NOT STERILE Storage: 2 C to 8 C See package insert

The Eye-Bank for Sight Restoration, Inc. 212-742-9000
 120 Wall Street, New York NY 10005 www.eyedonation.org

DONOR INFORMATION REPORT PAGE 1
 EBAA Accredited 03 MAR 2015
 Tissue Type CORNEA ID # 0321-15 Exp Date 2015-03-12

Age 48.00 Media/Lot# Optisol GS /W0007703
 Date & Time of Admission 2015-02-13 00:00
 Date & Time of Death 2015-02-25 17:16
 Date & Time of Insitu Excision 2015-02-26 01:20 Tech 0604
 Date & Time of Preservation 2015-02-26 01:48 Tech 0604
 Donor On Vent: N Length days Refrigeration Y at 21:36
 Cause of Death COMPLICATIONS OF METASTATIC UTERINE CARCINOMA
 Secondary COD

Med/Soc Interview UTERINE CANCER, LARGE NEPHROLITHIASIS, BILATERAL
 HYDROUTERONEPHROSIS, METS TO LUNG, LIVER, & LAD, DVT,
 COLONOSCOPY, OOZING RECTAL MASS, TUMOR NECROSIS,
 TAH, BSO, ANEMIA, CHEMOTHERAPY, S/P IVC PLACEMENT
 D/T GI BLEED, B/L URETERAL STENT, H/O SEPSIS
 (CLEARED) D/T TUMOR NECROSIS S/P DEBULKING

Ocular History No ocular history noted on chart review

Blood Sample POST MORTEM Accession Number 10268282
 Serology Lab VRL
 Serology Tests NR = Non Reactive POS = Reactive QNS = Not tested
 HBsAg 2015-02-28 NR
 HBcore Total 2015-02-28 NR
 HCV Ab 2015-02-28 NR
 HIVI/II Ab 2015-02-28 NR
 RPR 2015-02-28 NR
 HIV-NAT 2015-02-28 NR
 HCV-NAT 2015-02-28 NR
 HBV-NAT 2015-02-28 NR

THE EYE—BANK FOR SIGHT RESTORATION CORNEA in Optisol GS
 120 Wall Street, New York, NY 10005 (212) 742-9000 ID# 0321-15
 W3993 15 000321 Expiration Date 2015-03-12
 Product V0004000 Date/Time of Death 2015-02-25 17:16
 Date/Time of Preser. 2015-02-26 01:48
 Single Patient Use Only NOT STERILE Storage: 2 C to 8 C See package insert

Cornea Evaluation Date 2015-02-26 Tech 0112
 Epithelium SLIGHT EXPOSURE Lens Status PHAKIC
 Stroma 8.5MM CLR, S/M EDEMA, S ARCUS
 Descemet's Membrane 2+ FOLDS
 Endothelium VS IRREG, DIFFUSE SPOT CELL LOSS, PERI STRESS
 Endothelial Cell Density 2877 sq mm on 2015-02-26
 Pachymetry 530 um on 2015-02-26
 Comments EPI: S DIFF XP, PERIPHERAL IRREGULARITIES

Medical eligibility determined after reviewing information provided by
 MEDICAL CHART REVIEW & PHYSICIAN INTERVIEW
 and approved by Medical Director Designee(s):
 Christopher Ferro, CEBT

Surgical Count

Ensure that instrument and countable item checks are included in Time-Out and Sign-Out. Any additional items opened during the procedure also need to be added onto the count. In ophthalmology, count:

- trocars
- haemostats/arteries
- blades
- needles
- sutures
- cotton tips (intraocular excluded)
- raytec/gauze (intraocular excluded).

If any item is missing, the surgeon needs to be notified prior to wound closure. Every effort must be made to locate the missing items to ensure it is not inside the patient.

Preparing and Using Cytotoxics

Cytotoxics, also called antimetabolites, are used to kill cells. Particularly, they are used in pterygium and glaucoma surgeries. They need to be handled carefully to make sure that only the ocular cells that the surgeon wants to target are touched by the agent. This means:

- Adhering to UP and wear PPE
 - double-glove.
- Isolating a section of the sterile table to prepare and handle the agent, instrument and waste.
- Special waste management – sometimes in separate coloured bins.
- Notifying the sterilization team and waste team to use precautions.
- Notifying the first aid officer/manager of any spills.

WARNING: Mixing these drugs can be dangerous. It is strongly recommended that this be completed by the pharmacist who supplies them already mixed into individual vials. This costs more but protects staff from having to mix these harmful agents. It also means the mix (concentration) has already been calculated.

If this cannot be provided, then staff need to take all protective measures. Make sure that the surgeon checks the concentration and mix to ensure it is the strength they need.

Lastly, ensure that cytotoxics are disposed of safely and as per policy.

Managing Additional People in the OT

From time to time all OTs have to accommodate students, equipment representatives, new staff members and other visitors. It is important that the OT is as accessible as possible to these people without compromising privacy, care and safety for the patient, and a comfortable working environment for the staff and surgeon. Additionally, it is important that visitors form a good impression of the facility. Therefore, ensure best practice and policy is always followed – regardless of who the visitor is. Here are some suggestions to assist with the management of visitors to the OT:

- Develop a policy regarding visitors to the OT.
- Ask visitors why they are there and work out how best to facilitate them, i.e. medical engineer might be there to install new equipment (ensure appropriate permissions are given).
- Students will have learning objectives – ensure they are

provided with an adequate opportunity to achieve their learning goals.

- Restrict numbers to 1-2 visitors in each OT at a time. They may need to rotate in and out or be rescheduled.
 - communication between different visiting groups, i.e. nursing school and medical school, will ensure everyone is accommodated for within policy.
- Give visitors instructions on what they can and cannot do before they enter. It is important that they agree to the terms.
- Have visitors sign in and out (for safety). This may include agreeing to respect the facilities privacy policy.
- Dress them in surgical attire.
- Ask them not to talk to the surgeon, or approach the surgical area unless instructed to do so – to prevent distraction and contamination.
- Instruct them not to touch anything without permission (or outside of their scope of practice if they are a student).
- Instruct them to follow the lead of the staff – most likely from the scout nurse as this person is free to support and communicate with the visitor.
- Tell them that, if they need help, to let the circulating nurse know immediately so they can be assisted.

Note: some visitors who have never been in an OT can find the experience strange. Some visitors can also feel faint (and may indeed faint). Therefore, try and offer them a seat that is up against the wall. Additionally, tell them that if they feel faint that they are welcome to leave, so they can sit and have a drink or take some fresh air in order to recover.

End of the Case

Prior to wound closure

Just before the completion of the case, the scrub and circulating nurse complete the Sign-Out process together. This is conducted prior to wound closure to prevent items being retained in the surgical site. They notify the surgeon of anything missing, allowing the team the opportunity to locate item before the wound is closed.

At the completion of the surgery, the scrub nurse and/or circulator

- Remove all instruments, equipment and other items as soon as possible – this is particularly important if there is a GA, as access to the airways is important.
- Ensure all instruments and equipment are collected.
- Ensure all sharps are disposed of.
- Remove drapes and places them in the waste (5.32) or linen bin.
- Depending on surgeon preference, help clean the operative site, installing eye drops or ointment, or apply a dressing.
- Transfer instruments to the sterilization room.
- Complete paperwork.
- Depending on the size of the team, assist with the patient's transfer to recovery.
- Clean and prepare for the next patient.
- Follow-up on any issues (i.e. broken equipment).

End of the List/Day

At the end of the surgical list, or end of the day, the scrub and circulating nurse work together – alongside the anaesthetic nurse, to clean and tidy the OT. Any leftover items are returned to the storeroom, and the OT is cleaning as per policy, and the area is restocked ready for the next day.

Any specimens collected need to be removed from the OT and transferred to the pathology department.

Issues, such as broken equipment and instruments also need to be followed-up with the relevant managers.

Once completed, the team consults the surgical schedule to determine the surgical needs of the next list of patients. They then prepare for their arrival (i.e. tomorrow's list). This planning ensures the next day/session will run smoothly.



Photo 5.32: Remove contaminated waste.

SECTION 6

Equipment, Consumables and Prostheses Care.

Contributors: Ismael Cordero, Lynette Grubwinkler, and Heather Machin



A significant part of a nurse and technician's role is to ensure that the equipment used in the OT is safely maintained and being used for the correct purpose and in the correct manner. This section will explore common equipment used in the OT and provide some recommendations on management.

Equipment Maintenance Programmes and Specialists

In some larger facilities, a special maintenance department is available to provide maintenance services and support. This may include biomedical engineers, responsible for: equipment checks, instrument care and/or assistance with new purchases. In smaller facilities however this may not be available and the OT nurse manager may be responsible for hiring external engineers. This means the OT nurse manager needs to keep track of equipment needs. This can be done by putting in place routine and ad hoc equipment and system checks, which may include routine checks (i.e. scheduled annually or bi-annually), such as:

- infrastructure (i.e. HEPA filters for the air conditioner)
- electrical plug safety checks
- equipment safety checks, such as large equipment (i.e. anaesthetic machine and sterilizer), and smaller equipment (i.e. indirect ophthalmoscope), including:
 - equipment safety tagging
 - examining for fault or exposed wires
 - bulb checked and/or confirming that spare bulbs are available
 - removing items from service and/or replacement.

The system can also help:

- remove danger to the staff and patient
- help find replacements quickly to prevent delay in surgery services
- educate staff on how to use equipment safely and correctly
- completion of equipment and maintenance audits.

Storage

Equipment needs to be stored in a safe place while not in use. Place items in an air controlled room to prevent moisture and mould build-up (especially for the microscope) and cover with a dust protector.

Ensure equipment is not stacked tightly or on top of each other, and make sure wires are not kinked (twisted/bent). This will help prevent damage due to being pushed against each other.

With larger items such as a floor-microscope and an anaesthetic machine, less movement is best to prevent them from being knocked and damaged.

Gas cylinders and gas banks

Gas cylinders can be dangerous if they are not properly cared for. They need to be:

- stored in an upright position
- chained/secured – i.e. to a cylinder trolley or the wall
- have a gauge regulator in place so that they can be monitored
- kept somewhere safe and inaccessible to the public
- mobilised on a trolley to prevent them from falling over.

Some larger facilities have what is called a Gas Bank whereby cylinders are kept away from the OT and the gasses are piped into the OT via wall-sockets. In this system, most banks have electronic alarms alerting that the cylinders need to be switched over. This is

to prevent running out of gas. The bank allows for multiple cylinders to be on standby and the staff member just needs to flip over the valve to the new chamber. This works effectively but a replacement or re-fill system must be in place to ensure empty cylinders are changed over as soon as possible. Without a specific Gas Bank, staff need to routinely check cylinder levels.

Storage and Cleaning (of Optical Items)

Knowledge of the specific device is important prior to cleaning any optical item. It is important to note that many ophthalmic devices have:

- optical components such as windows, lenses, mirrors, filters, and prisms
- very small irregularities (such as scratches) that can cause unwanted scattering of light, which reduces quality
- a surface coating (i.e. on lenses, prisms, and windows), that have an antireflective layer to prevent loss of light due to reflection
- mirrors which have a highly reflective coating to get maximum reflection of light
- filters which have a coatings to cut out undesired wavelengths. The coating can be very thin and delicate and can be damaged by improper handling and cleaning.

Cleaning

- The lenses must be cleaned with a spectacle cloth after each use. Water must not be put on the lens. If moisture is required, breathing onto the lens before wiping with the cloth is acceptable.
- If the climate is humid, the items should be kept in a well-ventilated but secure cupboard. (Moisture causes rust formation on frames.)
- Fungus can grow on the lens. It is advisable to air items, i.e. loupes in the sunshine each week if they are not being used frequently.
- Lenses must not be touched with bare fingers.

General care

- Place a dust cover over eye care equipment when not in use.
- Always replace the lens caps, if available, when not in use.
- Keep eye care equipment in an environment that is not humid; this will prevent the growth of fungus on optical components.
- Repeated cleaning will wear out the surface coating described earlier, and the property of the surface may change. It is better to protect optical components from dust, stain and fungus.

Before cleaning

- Read the manufacturer's instructions.
- If the optical component is not dirty, do not clean it.
- Laser optics should only be cleaned by trained, qualified specialists.

Cleaning materials

- dust blower
- lens brush, which is sometimes attached to the dust blower

- lint-free lens tissue (available in photography shops)
- optical cleaning solutions (see below)
- lint-free cotton gloves
- bamboo tweezers
- cotton swabs. Use non-sterile, medical-grade cotton swabs, with degreased fibres that will not release lint. If these are not available, fresh cotton swabs can be prepared with wooden sticks and medical-grade cotton.

Optical cleaning solutions

First consult the manufacturer to obtain the recommended solutions. If this is not possible, commercial lens-cleaning solutions sold in camera shops can be used for most optical cleaning. Otherwise, the following - going from weakest (1) to strongest (4) until the surface is clean - are suggested:

1. use of distilled water
2. a water-based solution: 1 part mild, neutral detergent to 19 parts distilled water
3. a mixture of 60% acetone and 40% methanol (not for use on plastic lenses)
4. isopropyl alcohol (90% purity). Note: slow evaporation can leave drying marks on the surface.

Tips for cleaning

- Do not touch optical surfaces with bare fingers, because they leave behind grease and moisture marks that are hard to remove. Wear cotton, lint-free gloves if available and hold loose optical components by their edge.
- Be careful of sharp instruments, including fingernails, near optical surfaces. Use wooden, bamboo, or plastic implements instead. Always place optical components on a soft surface to avoid scratches.
- Do not apply optical cleaning solutions directly onto the optical components of a device, since these can enter the machine and cause spots on other lenses or otherwise damage the device. Instead, apply the cleaning solution to the lens paper or swab first.
- When removing stains, avoid excess pressure since this can remove the delicate surface coating.

Steps

1. Always remove dust first. Dust particles can produce scratches. Never wipe dust off optical surfaces, especially when they are dry. First use a dust blower to remove dust. Use a camel hair brush, sometimes included as part of the blower, to remove any dust that sticks to the surface.
2. To remove stains, use a lint-free cotton swab or a lens-cleaning tissue dipped in the optical cleaning solution. For round surfaces, move the swab or tissue in a circular path, starting from the centre and going in a widening spiral towards the edge. For rectangular surfaces, use repeated strokes, parallel to each other and in the same direction, until all surfaces have been covered. Repeat this step, using a fresh swab every time, until the stain is no longer visible at any angle under a bright light. If cotton lint is left on the component, remove it using the blower or a clean lens brush.
3. To remove stains on plastic components, use optical cleaning solution number 2 (the water-based solution). Do not use other cleaning solutions on plastic, unless indicated by the manufacturer, because they can permanently cloud the surface.
4. To remove fungus, use an optical fungicide. If unavailable, use surgical scrub soap.

Optical Items

This Section provides an overview of some of the common equipment found in the ophthalmic OT. This is not exhaustive and it is recommended that the manufacturer's guidelines are reviewed for specific machines.

Operating loupes

Operating loupes (Photo 6.1) have been used for many years, for both intraocular and extraocular work. They have been superseded for intraocular work by the operating microscope. As cataract surgery in lower resource locations increasingly moves towards intraocular lens implantation, the need for high quality, teaching and portable operating microscopes has become greater. An operating loupe cannot always give the high definition or depth of field required, nor pick up the red reflex, all of which are important when implanting anterior or posterior chamber lenses. Loupes remain important for extraocular examination and surgery.

- Loupes are attached to spectacle frames (to which prescription lenses may be added) or to a headband.
- The type purchased depends upon the surgeon and need.
- Loupes are heavy and need to be carefully handled. They should be stored in the box when not in use.
- Loupes magnify the image depending upon their power. They can magnify between 2 and 6 times.
- The higher the magnification the smaller the operating field.
- The surgeon will adjust the loupes to accommodate their pupillary distance (PD). It is therefore advisable for surgeons to have their own loupes.
- Some loupes are attached to a headlight to assist the surgeon. The position of this light is crucial so that no shadow is created over the operating field.
- New staff should be taught how to put loupes onto a surgeon's head. They can be very uncomfortable if not worn correctly.



Photo 6.1: Operating Loupes

Operating microscopes

An operating or surgical microscope is an optical instrument that provides the surgeon with a stereoscopic, high quality magnified and illuminated image of the small structures in the surgical area.

The optical components of a basic stereo microscope consist of the binocular head, a magnification changer, the objective lens and an illuminator which beams light through the objective lens and onto the operating field (Photo 6.2). The binocular head consists of two telescopes with adjustable eyepieces for users with refractive error, which can also be adjusted to suit each user's pupillary distance (PD). The eyepieces are interchangeable and available in four magnifications: 10X, 12.5X, 16X and 20X. In ophthalmic surgery a 12.5X magnification is generally used.

The magnification can be changed by turning a knob (which selects different magnification lenses) or by using a motorized zoom controlled by a foot pedal.

The working distance (Figure 6.1) is the distance from the microscope objective lens to the point of focus of the optical system. This value is fixed and is dependent on the chosen focal length of the objective lens. The choice of working distance depends on the type of surgery. For modern ophthalmic surgery that involves delicate work in the posterior chamber, objective focal lengths of 150 mm, 175 mm and 200 mm are commonly used.

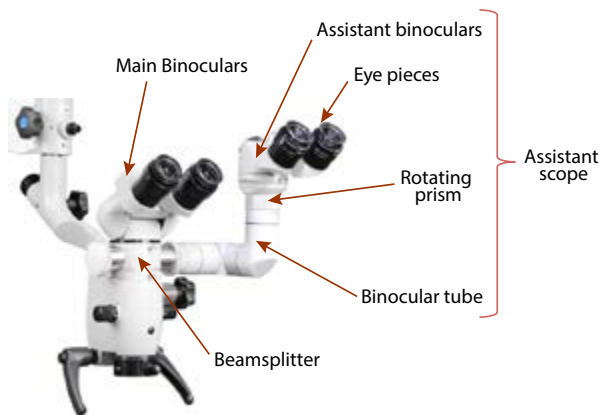

Photo 6.2: Operating microscope head

The optical system is attached to the suspension arm of the floor stand (Photo 6.3). The suspension arm makes it possible to position the optics exactly and to fix them in place. The floor stand has wheels and can be moved around the floor and fixed into place using the brakes.

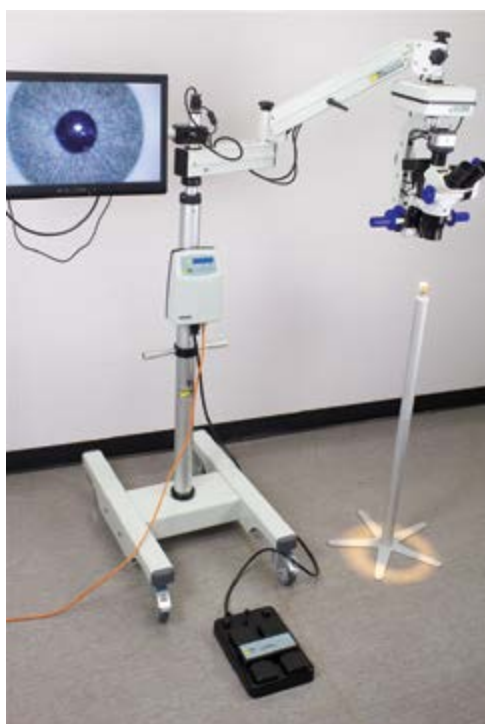

Photo 6.3: Operating microscope head attached to suspension arm and floor stand. Operated by a foot pedal.

A foot pedal connected to the floor stand, allowing the surgeon to control the focus, the zoom, the position of the optics over the eye (the x, y position on the horizontal plane) and to turn the illumination on and off.

The illumination system is usually housed in the floor stand in order to keep the bulb heat away from the operating field. In this case, the light is transmitted to the operating field by means of a fibre optic cable. The light in ophthalmic microscopes is usually coaxial, meaning that it follows the same path as the image in order to avoid shadows. Modern microscopes have a double bulb system so that if one bulb blows the second can be used. On some microscopes a fan will turn on automatically when the light is switched on, to keep the light bulb cool. The fan will often stay on for several minutes after the light has been turned off to speed the cooling process.

Some microscopes also have yellow and white light available. Ask the surgeon what they would prefer if this option is available.

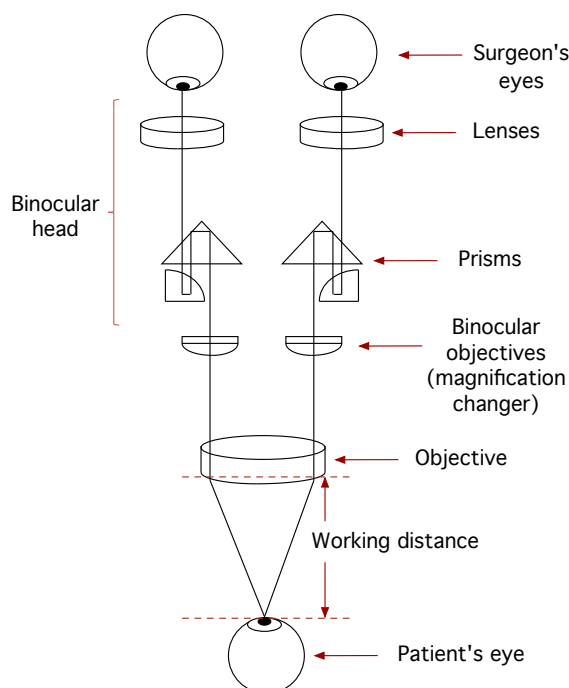

Figure 6.1: Working distance and optical system

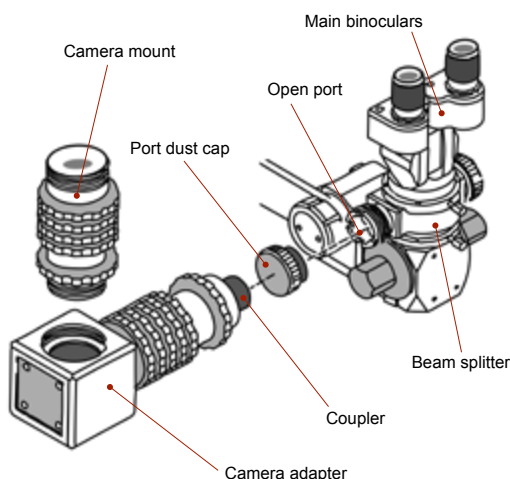

Figure 6.2: Beam splitter to allow for assistant viewing.

Hazards of microscope lights

The light that is emitted from a microscope is very intense. Direct high intensity illumination can affect the patient's macula resulting in permanent damage. Many microscopes have yellow filters or a filtering spot to reduce the light intensity. If there is no filter on the microscope the patient's macula can be protected by a moistened cellulose swab placed over the eye, e.g. during suturing. The light intensity should be regulated, and not increased unless it is really necessary.

Assistant scopes

Microscopes often include a second set of binoculars, part of which is commonly called an assistant or teaching scope, which allows another person to view the operation at the same time as the surgeon in charge.

This is made possible by the beam splitter (Figure 6.2), which connects the assistant scope to the main visual path of the operating microscope. The optical components of the assistant scope (Photo 6.2) are almost identical to the main scope and consist of either fixed or inclinable binoculars. These have adjustable eyepieces for users with refractive error and a stereo observation tube that makes it possible to adjust the binoculars to a position comfortable for the assistant surgeon or trainee.

In modern microscopes, the magnification and focus of the assistant scope match those of the main scope and are controlled by the surgeon in charge, using the foot pedal.

The assistant scope has a rotating prism that allows the observer to orient the field of view. For observation or teaching, the field of view of the assistant scope coincides with that of the main scope, used by the surgeon. For example, if the surgeon says 'See the spot at 3 o'clock', the observer must also see it at 3 o'clock. For an assistant surgeon, the field of view of the assistant scope must be oriented to match the assistant's own position. The position of 3 o'clock as seen by the main surgeon would thus be at the 6 o'clock or 12 o'clock position for the assistant, depending on whether they are located (sitting) to the right or left of the main surgeon.

The beam splitter (Photo 6.4) splits the light path to allow a video camera, digital camera, or an assistant scope to be attached to the microscope. Beam splitters can have one port, or adapter, or two ports. Video vision can be sent to an accompanied TV screen (Photo 6.3).

Each beam splitter has a specific split ratio such as 50:50 or 70:30. The split ratio is marked on the body of the beam splitter.

In the case of a 50:50 beam splitter, the amount of light is split equally between the main binoculars and the attachment(s), which is needed when an assistant scope is used.

A 70:30 beam splitter is used for photography and video. In this case, 70% of the light is directed to the main binoculars while the other 30% is directed to the attachment where the camera is connected.

The assistant scope, camera and other attachments connect to the beam splitter by means of a coupler that is made to fit the port of a particular model of beam splitter (Photo 6.4).

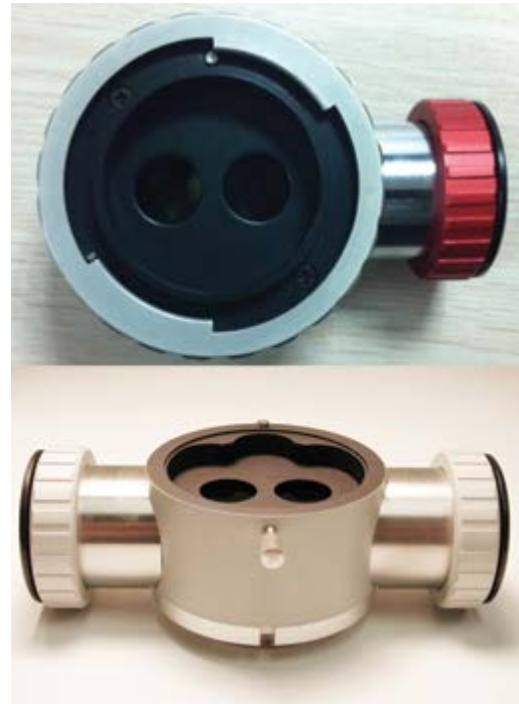

Photo 6.4: Beam Splitter

Useful tips concerning assistant scopes

- It is important to note that beam splitters, assistant scopes and other attachments are made for specific models of operating microscopes. For instance, if the facility has an Ocuscan model microscope, then a compatible Ocuscan model beam splitter and assistant scope is required. Many beam splitters and other attachments made by one manufacturer will not work on other brands of microscopes.
- Adjust the balance and tension settings of the microscope suspension arm following the addition of beam splitters, assistant scopes, cameras and other accessories. Also, the surgeons may need to familiarise themselves to the weight and balance of the additional equipment. There is a limited amount of weight a suspension arm can effectively hold. This weight is normally labeled on the suspension arm and, if not, this information can be found in the microscope's user manual.
- If considering obtaining an operating microscope for microsurgical training, it is an absolute necessity to have an assistant or teaching scope. Without it, microsurgical training cannot be effective.
 - note: refurbished assistant scopes and beam splitters can cost much less than new units.
- If not planning to use an assistant scope or camera, or to video record the operation, it is always good to remove the beam splitter and assistant microscope, camera or other attachment, so that the image brightness is better.

Caring for the operating microscope

It is essential that all facilities develop protocols for performing microscope checks. Microscope optics should be inspected and cleaned on a weekly basis, or earlier if dirty. The entire microscope should be checked by a biomedical equipment technician at least once every six months.

- Keep the microscope in a dry, cool and well-ventilated place to prevent fungus growth on the optics (lenses).
- Every week, clean the optics according to the optical cleaning instructions.
- Fungus and mould growth are a particular and difficult

problem with microscopes, and are mainly related to above average humidity. The risk varies greatly, but the effect of fungus and mould growth on lenses and prisms can cause irreversible damage. Fungicidal pellets are available from several microscope suppliers. A good supply is advised although they last several years. Some microscopes are manufactured with fungicidal pellets already in place. This is indicated on the supplier's instructions.

- Microscopes and loupes are protected from fungi and mould if the following environment can be assured:
 - dry, low humidity
 - low temperature
 - good ventilation
 - lens surfaces free of debris
 - cleaned appropriately
 - weekly exposure to sunlight.
- Protect it from dust when not in use with a dust cover. Vinyl coverings are preferred because they do not shed lint (like cloth covers do). However, their use should be avoided in humid environments since they can trap moisture, which increases the risk of fungal growth.
- Wipe down the external surfaces with a damp cloth soaked in hot, soapy water.
- Cover the foot pedal with a clear plastic bag to prevent surgical and cleaning fluids from entering and damaging the electronics.
- Lift the foot pedal off the floor when washing the floor.
- Use a voltage stabiliser with the microscope. This will prevent sudden increases in voltage from destroying the bulbs and will ensure that the illumination provided remains constant.
- Before using, test the controls of the foot pedal (the x, y movement, zoom, and focus, light on and off).
- Before using, check that the suspension arm can be fixed into position to ensure that it does not fall on the patient.
- Avoid kinking or bending the fibre optic cables.
- When replacing the bulbs, avoid touching them with fingers. This is because oil from fingerprints can be left on the bulb and shorten its life.
- Do not move the microscope while the bulb is still hot because strong vibrations may damage the filament.
- Every six months, clean and oil the wheels and the brakes. Remove any surplus oil when done.
- Rubber control handle covers, which can be sterilized, are available from several microscope manufacturers. Alternatively, they can be made out of cloth.

Accessory items

For procedures such as a vitrectomy, the team may be required to add onto the microscope a laser filter and additional viewing systems. This is generally placed under the surgeon's eye piece. If placing these items onto the microscope always make sure:

- the accessories are compatible with the laser and viewing system intended for use
- turn on the break, to prevent it from moving
- place a table under the head so you can place the items onto it
- be careful not to damage the eye-pieces and the accessory items
- ensure the fit is comfortable – do not force it onto the machine
- screw securely to the touch – if screwed too tightly it will be difficult to remove and may damage the thread long term
- check that the piece is secure – not moving

- move the table away
- check the weight-balance. To do this, hold onto the head-piece while someone else slowly releases the break. This prevents the head from dropping quickly (on older microscopes);
 - many older machines have a dial/knob on their arm which can be used to change the weight of the head. Manipulate the dial until the head can hold itself without dropping
- always have the surgeon check the accessories and weight before the first patient enters the OT.
- These have been designed for use for outreach programs. Some can be powered by a car battery.
- They are light, easily assembled, but still very delicate.
- The manufacturer's instructions must be followed when assembling and packing away.
- The correct size spanners, Allen keys, spare bulbs and fuses, and jump leads must be readily available.
- A hard protective suitcase with foam packing, in which to pack the microscope is required.
- Detachable eyepieces should be wrapped in a plastic bag.
- If the microscope is not in constant use, the optics should be exposed to sunlight every week. This helps prevent fungal growth on the lenses.
- The microscope must be dry before storing.

Type of microscope:

Currently, there are 3 main types of microscope.

1. **Floor** – movable: Most machines are floor movable. This makes them versatile, though it does take up quite a lot of space in the room. Issues may arise if they are knocked or bumped while being moved. Move them with two people, one pushing and the other guiding (Photo 6.3).
2. **Ceiling mounted** - These are better options for OTs that will be used for the same type of surgeries. An issue to be aware of is the height and strength of the ceiling. The weight will need to be known before purchasing, to ensure the ceiling can bear it. A coordinated instalment, with the electrical and building teams, will also be needed so that wiring can be completed.
3. **Bed or table mounted** - Used for rural mobile services. Easy to pack and un-pack for travelling teams. Issues arise if the staff member has not anchored it to the bed correctly as this may cause harm to the patient or hinder the surgeon if it moves (Photo 6.5).

Regardless of which type is selected for the hospital, staff need to ensure that it is the most appropriate for their setting.



Photo 6.5: Table mounted microscope

Electrosurgical units

Electrosurgery is used routinely in eye surgery to cut, coagulate, dissect, fulgurate, ablate, and shrink tissue. High frequency (100 kilohertz to 5 megahertz) - alternating electric current at various voltages (200 to 10,000 Volts) is passed through tissue to generate heat. An electrosurgical unit (ESU) consists of a generator and a handpiece with one or more electrodes. The device is controlled using a switch on the handpiece or a foot switch.

Electrosurgical generators can produce a variety of electrical waveforms. As these waveforms change, so do the corresponding tissue effects.

By using a constant waveform the surgeon is able to vaporise or cut tissue. This waveform produces heat very rapidly.

Using an intermittent waveform causes the generator to modify the waveform so that the duty cycle ("on" time) is reduced. This interrupted waveform will produce less heat. Instead of tissue vaporisation, a coagulum is produced.

A "blended current" is a modification of the duty cycle. When going from Blend 1 to Blend 3 the duty cycle is progressively reduced. A lower duty cycle produces less heat. Consequently, Blend 1 is able to vaporise tissue with minimal haemostasis whereas Blend 3 is less effective at cutting but has maximum haemostasis.

In bipolar electrosurgery (Figure 6.3), both the active electrode and return electrode functions are performed at the site of surgery. The two tips of the forceps perform the active and return electrode functions. Only the tissue grasped is included in the electrical circuit. Because the return function is performed by one tip of the forceps, no patient return electrode is needed. Bipolar electrosurgery operates regardless of the medium in which it is used, permitting coagulation in a fluid environment. This is a great advantage when attempting to coagulate in a wet field. As a result, bipolar electrosurgery is often referred to as "wet field" cautery.

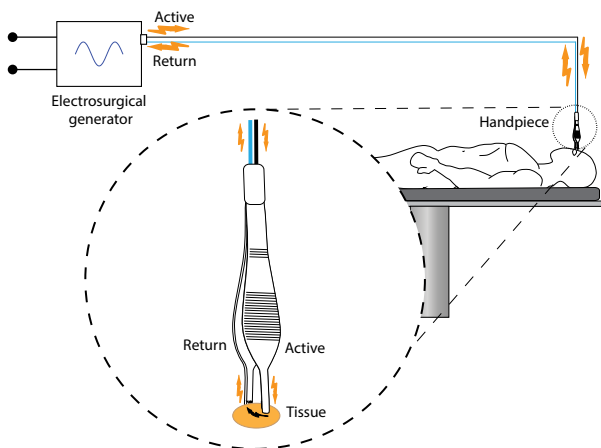

Figure 6.3: ESU Bipolar

In monopolar electrosurgery (Figure 6.4), the active electrode is in the surgical site. The patient return electrode is somewhere else on the patient's body. The current passes through the patient as it completes the circuit from the active electrode to patient as it completes the circuit from the active electrode to the patient return electrode.

The function of the patient return electrode is to safely remove the current from the patient. A return electrode burn will occur if the heat produced, over time, is not safely dissipated by the size or conductivity of the patient return electrode.

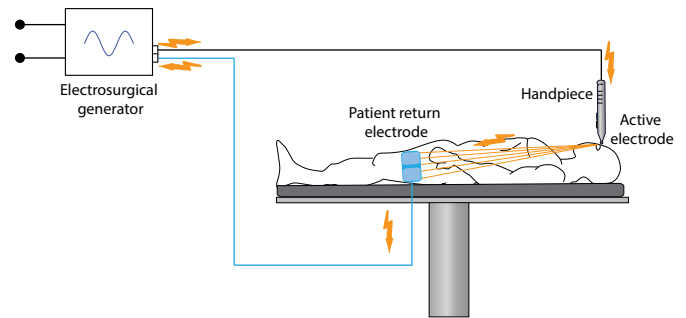

Figure 6.4: ESU Monopolar

Modern electrosurgical machines have one or both of the following built in safety features to prevent burns from occurring (due to poor contact between the patient and the return electrode) when using the monopolar mode:

- Return Electrode Monitor (REM) – A circuit that measures the impedance of the return electrode. If the impedance is greater than 30 ohms, an alarm will activate and the ESU will not operate. A REM monitor uses a special type of return electrode, which has two separated surface areas.
- Return Fault Monitor – A circuit that measures the current leaving and returning from and to the ESU. If all the current leaving does not return, the alarm activates and the ESU will not operate.

Electrosurgery vs. electrocautery

Often the term "electrocautery" is incorrectly used to describe electrosurgery. Electrocautery refers to direct current (electrons flowing in one direction) whereas electrosurgery uses alternating current. In electrosurgery, the patient is included in the circuit and current enters the patient's body. During electrocautery, the current does not enter the patient's body. Instead, the current flows through a heating element, which burns the tissue by direct transfer of heat. Electrocautery or, more precisely, thermocautery units (Figure 6.5) are usually portable battery powered devices that can be either disposable or reusable.

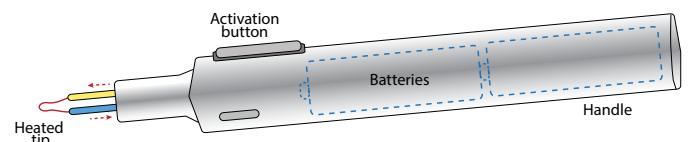

Figure 6.5: ESU Thermocautery units (battery powered)

Using ESU safely

ESUs produce very high currents that can cause patient and operator injury if not properly used and maintained. Many problems have been associated with the use of ESUs – predominantly with monopolar, such as burns at the return electrode site and surgical fires. Some of these problems can be avoided by simple safety precautions such as the following:

- ESUs should not be used in the presence of flammable agents or in oxygen enriched environments.
- Avoid using flammable substances that can be ignited by sparks, such as alcohol and skin degreasers. If using alcohol-based skin preps, do not allow them to pool near the dispersive pad; be sure prep solutions are thoroughly dry and fumes have dissipated before ESU activation.
- The hand piece should always be placed in the non-conductive holster when not in use.
- Rubber catheters or other materials should not be used as a sheath on active electrode tips.
- Cords should never be wrapped around metal instruments,

as RF current can pass into the metal instrument, causing burns.

- Always use the lowest possible generator setting that will achieve the desired surgical effect. When higher than necessary voltages are used, the chances of arcing are increased. If the surgeon continues to ask for a higher setting, this could be a signal that the integrity of the skin/dispersive pad interface is compromised.
- Clean the electrode tip frequently. As eschar (dead tissue from burning) builds up on the tip, impedance increases and can cause arcing, sparking or ignition and flaming of the eschar. When cleaning the electrode, the eschar should be wiped away using a sponge rather than the common scratch pad, because these pads will scratch grooves into the electrode tip, increasing eschar build-up.
- Determine whether the patient has any metal implants, including cardiac pacemakers and defibrillators, or a wire bra (remove the bra). There is potential for patient injury if a dispersive pad is placed on the skin over a metal orthopaedic implant.
- For optimum safety, have the patient remove any jewellery to avoid complications from possible current leakage.
- Position and insulate the patient so that they are not touching any grounded metal objects.
- Choose a location for the dispersive pad that is as close to the operative site as possible, clean and dry, well-vascularised, and over a large muscle mass. Avoid bony prominences, adipose tissue, and scar tissue, skin over implanted metal prostheses, hairy surfaces, and pressure points. If necessary, shave very hairy skin at the dispersive pad site. Make sure that conductive gel is moist and uniformly spread all over the contact area, and that the dispersive pad achieves uniform contact with the patient's skin.
- Position ECG electrodes away from the electro-surgery site or the current pathway through the body.
- Do not use sharp towel clips or metal instruments to attach cables to drapes. Sharp metal clips can damage electrical cables or provide an unwanted point of contact with the patient's skin. Overlapping electrical wire around the metal clip creates an electrical transformer that can cause a hazard and may ignite drapes.
- Never operate electrosurgical equipment with wet hands or wet gloves. Sterile gloves that have holes in them will allow electrical current transmission. Be sure team members at the field have intact gloves.
- Never operate electrosurgical equipment while standing on a wet surface. Keep the foot pedal dry. Protect it from fluid spillage by covering it with a clear impervious cover.
- Select adult or paediatric plates as required.

Cryotherapy machine

Cryotherapy machines, also known as cryosurgery machines, continue to be widely used for surgical procedures of the eye such as retinal detachment repair.

Cryotherapy machines (Figure 6.6) control the release of a compressed gas, stored under high pressure in a cylinder. When the foot pedal is depressed, the gas is regulated to a lower working pressure and pumped to the metal tip of a cryoprobe, where it expands rapidly. This reduction in pressure cools the gas and the tip freezes very quickly. Release of the foot pedal causes warm low-pressure gas to flow through the probe for defrosting.

The main compressed gases used for cryotherapy are carbon dioxide (CO₂) and nitrous oxide (N₂O). Nitrous oxide is more effective for

cryotherapy, but in many low-resource settings, carbon dioxide is

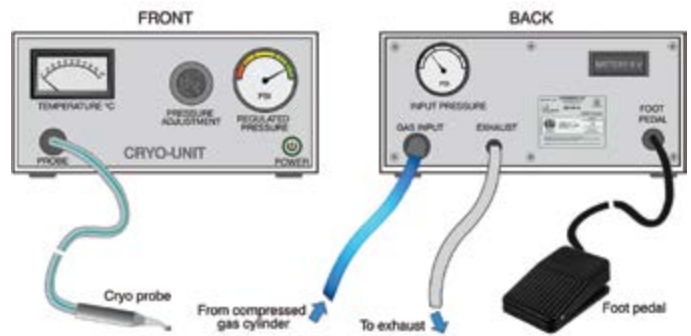

Figure 6.6: Cryotherapy machine

often less expensive and readily available.

The pressure gauge on the back of the machine (in the case of the model in Figure 6.6) indicates how much gas is inside the cylinder. The pressure gauge in the front indicates the regulated or 'working' pressure that is applied to the probe. This pressure can be adjusted using the knob on the front, according to the strength of cooling that is desired and the type of probe used, as per the manufacturer's recommendations. The higher the working pressure the greater the cooling.

Many probes have a thermocouple that measures the temperature at the tip and this measurement is displayed on the temperature gauge on the front of the machine. Most standard cryotherapy machines do not have to be connected to an electrical outlet but may require a small battery to power the temperature gauge.

Avoiding exposure to N₂O

The concentration of N₂O in the room can reach several thousand parts per million during a cryosurgical procedure if the exhaust gas from the probe is not vented properly, and levels may remain elevated for a long time. Exposure should be minimised to prevent the short-term behavioural and long-term reproductive health effects that can be caused by N₂O.

Most modern N₂O cryotherapy units are equipped with an exhaust. A length of plastic tubing available from the manufacturer can be connected directly to this port, with the other end connected to a discharge location outside the building. Remember:

- always discharge N₂O outside of the room, away from any air-intake ducts
- do not vent the N₂O into a sink, drain trap, air recirculation duct, or the piped medical/surgical suction system
- consult with the manufacturer to determine which scavenging methods they recommend for their equipment.

Before use

- Ensure that the gas cylinder is properly secured.
- Store the cylinder upright for a minimum of eight hours at ambient room temperature prior to use.
- Ensure that the gas cylinder is full, properly connected to the machine and that the cylinder valve is fully open. Ensure that the;
 - exhaust hose is connected and directed to a proper discharge location, as stated above
 - machine is tested immediately before use. This can be achieved as follows:
 - Immerse the probe tip in water. Simultaneously place foot on the pedal to release some gas. Then remove the probe from the water and remove foot from the

pedal. A 2 cm ice ball should form at the tip

- If the ice ball does not appear, then the machine is faulty or the gas cylinder is almost or completely empty
- note: the freezing action should continue only so long as the foot pedal is depressed.

During use

- always vent N₂O outside of the room, away from any air intake ducts
- do not constrict, kink, bend, lay objects on, or otherwise damage or restrict probe or exhaust lines
- do not attempt to insert or remove the probe at the probe jack when the cryosurgical machine is pressurised.
- After use
- turn off the cylinder and depress the foot pedal to release all the gas in the tubing and probe. If this is not done, the tubing and probe can become damaged as the N₂O leaves deposits inside the tubing
- wipe the machine with a damp cloth
- sterilize the tubing and probe according to the manufacturer's instructions
- wipe the foot pedal with a damp cloth and dry it before storing
- protect the machine with a dust cover.
- change the cylinder, if necessary, before the next operation.

Basic troubleshooting

If the probe tip is not freezing sufficiently, this could be due to any of the following:

- The regulator is not functioning, which means there is not enough N₂O moving through the machine. The regulator can be replaced, but an experienced technician should do this.
- There is leaking gas at the cylinder head. Check that the hardened rubber O-ring at the junction of the cylinder and machine is present and in good condition.
- The cylinder is empty, or the pressure is too low in the cylinder. Replace the cylinder.
- There is residual moisture in the probe following sterilization. Re-purge the probe.
- Probe blocked for unknown reason. Replace the probe.
- Exhaust hose is blocked or occluded. Check the exhaust hose for blockages or occlusions and replace if necessary.

Lasers in Surgical Ophthalmology

Laser devices are frequently used to treat a number of eye conditions. A basic understanding of how medical lasers are used and the safety protocols required during treatment, is an important part of ophthalmic nursing practice. Laser units are classified as a radiation source and require the implementation of safety procedures for their use. This section will outline basic guidelines for laser use in OT and/or consulting rooms.

The term Laser is an abbreviation of "Light Amplification by Stimulated Emission of Radiation" (Gordon, 1959). In other words, the light generated is changed or intensified within the unit and then aimed at a specific treatment site such as within the eye. The light energy produced by a laser has four characteristics which include wavelength, frequency, velocity and amplitude. The wavelength is a significant factor in matters of safety.

Lasers are safe when used appropriately to treat patients. However,

there is a risk to the eye/s of observers by unintentional, direct or indirect exposure to the laser beam. Laser light may be visible or invisible to the human eye and the range of the light/wavelength is usually measured in nanometres (nm). Of concern here, are lasers with a range of 400nm to 1400nm. The light from these lasers can easily be transmitted through ocular media, that is, it passes through the eye to the retina causing damage to highly sensitive tissue.

Laser units are categorised according to 'class' which indicates the level of risk to the unprotected eye. The Australian Radiation Protection and Nuclear Safety Agency (ARPNSA, 2016) defines the range as Class 1 - least harmful, to Class 4 - significant eye hazard. In ophthalmology most laser devices will be Class 3B or Class 4. Always refer to the manufacturers' label to confirm.

Safety devices and protective equipment

The greatest hazard associated with the use of the laser is the risk of damage to the eye due to unintended exposure, either directly or indirectly, through scatter. Providing Personal Protective Equipment (PPE) for staff is necessary to prevent harm. A person's blink response is not adequate enough to protect the eye when these lasers are used.

Protective eyewear or glasses must be specific to the wavelength of the laser device. To ensure they match, read the wavelength (nm) and optical density (OD) measurements which are stamped on the front of the safety glasses. This must correspond with specifications on the laser warning label generally located on the back of the device. The specific safety glasses filter the wavelength of the light, making it safe to view the treatment beam when worn.

It is important to take care of these safety glasses, as the protective coating can be easily damaged. Do not place the glasses' lenses down on any surface. Instead, return them to their protective case when not in use.

Each laser unit will have a filter system that will protect the user (i.e. physician) from exposure to the treatment beam. Some of these filters work automatically, bringing the filter across, when a button or pedal is pressed, and others must be manually installed and left in place during treatment. Before laser treatment begins, it is important for staff to check that the manual filter is in place. Manual filters will have a small lever that moves the filter across. On a microscope the laser filter must be placed in the correct position, normally below the surgeons' viewing eye piece.

The circulating nurse (and other attending staff/visitors) in an OT where a laser is used, need to wear a pair of safety glasses and help place a pair over the eyes of a surgical assistant or scrub nurse, so that everyone is protected.

The physician, as the laser operator, should be protected by either a manual or automatic filter that is generally fitted to the microscope, prior to commencing surgery. If this is not available, then the surgeon will also need to be fitted with the correct pair of safety glasses.

Signage

Signage should be placed on the outside of all entrance doors where the laser device will be used. There is a standard sizing and colour requirement for these signs, so that they can be easily seen and read before approaching the treatment room. Suggested wording includes:

- name of the class of Laser
- avoid eye or skin exposure
- wear Laser protective goggles

Use of a warning colours, i.e. yellow and a recognised 'symbol' will assist in ensuring attention to the sign.

If possible, install a warning light above or beside the entrance doors. This will need to be switched on prior to laser use. If a warning light is not available, install a second safety sign indicating that the Laser has been switched on.

Windows

If the laser beam is inadvertently reflected off or through glass, the reflections can be hazardous, therefore cover or blackout any windows. Use fire resistant material or blinds where possible on the inside of laser treatment rooms. Viewing from outside the room should be prevented. Check that there is still good internal lighting for safety when moving around the treatment room. A dedicated room for laser treatment is ideal. It minimises damage to the laser device and keeps all safety equipment in the same location.

Other safety concerns

- Access to the laser key and any spares should be restricted. All keys should be kept in a safe place and only appropriate medical staff should be allowed to collect them.
- Laser treatment should be administered only by a qualified professional (e.g. ophthalmologist) who has had the required training.

Other possible hazards include damage to the skin. The effects range from mild erythema to severe blistering but this is also dependent on the wavelength of the laser. A laser is also recognised as a potential electrical, fire or explosive hazard. Ensure the availability of appropriate fire extinguishers or fire blankets near treatment areas.

Appointing a laser safety officer

The appointment of a Laser Safety Officer (LSO) is an important workplace strategy. In many countries it is a legal requirement to have an appropriate person in this role. They are responsible for making sure that regulations are followed by all staff involved with the use of the laser; protective devices are checked, and reports on damage to equipment or safety glasses have been completed. They also manage replacements and repairs in conjunction with any maintenance teams. The LSO may also be required to assist with training staff about basic, safety issues of laser use.

Types of lasers

While new ophthalmic lasers are being introduced, there remain two common types used. These are 1). Argon, and 2). YAG.

- Argon lasers are generally used to treat retinal disorders such as diabetic retinopathy and associated conditions, i.e. retinal tears, leaking exudate and bleeding vessels. It may also be used for cyclodestruction (of the iris), which improves the flow of aqueous from the anterior chamber to help control intraocular pressure. The application of this laser can be delivered via an indirect ophthalmoscope, slit lamp or sterile endoprobe during surgery.
- YAG laser is delivered via a slit lamp system and is used to treat posterior capsule opacification (PCO) that may occur sometime following cataract surgery or for peripheral iridotomy (PI) treatment of narrow angle glaucoma.

Note: YAG lasers may be labelled Class 3B and are different to Argon Class 4. However, all safety procedures should still be followed. Laser safety glasses will differ due to different laser wavelength. This must be checked each time, prior to use, to avoid any mix up of safety glasses.

Lasers can be used externally (indirect) via a hand-held lens, or inside the eye (direct) via a laser probe (sometime used during retinal surgery).

Treatment lenses

The delivery of laser treatment will also require specific ocular lenses that have a range of different levels of magnification. These lenses may be used indirectly or by contact with the surface of the eye. For lens care, read the manufacturer's instructions, as some lenses are not sterilizable but require decontamination between use. Keep lenses in their protective cases when not in use.

Laser Safety Checklist

The information below outlines items to include on a Laser Safety checklist. The check should be completed when setting up the OT (procedure room) and packing up each day.

- Staff have received basic laser safety training.
- Laser is in good condition and maintenance records are up to date.
- Laser key is available.
- Safety glasses are available for all staff in the treatment area. Have one pair available on the outside of the main entrance door in case staff need to enter during treatment.
- Safety glasses match the laser device.
- Correct signage is in place.
- Warning light is turned on and/or another warning sign LASER IN USE is in position on all entrances before treatment begins.
- All doors are closed during treatment.
- Window coverings are in place for the treatment room. Room lights should be adequate for safety whilst moving around treatment room.
- Correct laser filter is installed on the microscope.
- The manual operated filter lever is in the correct position to protect the surgeon before the laser treatment begins.
- Documentation of treatment is in the patient record (completed by the person performing the laser procedure).
- Safety glasses are returned to protective cases.
- The laser key is stored in a safe place when the unit is not in use. Do not leave the key in the laser unit.
- Once treatment is complete, turn off the 'laser in use' light or turn the signage around.

Consumables and Prostheses

Checking of consumables and prostheses is important to prevent injury and risk to the patient. This section will briefly discuss common ophthalmic items. Please see section 9 for further information on stock management and ordering principles.

Any prosthetic (implantable) item that is retained in the patient, after the operation, needs to be documented in the patient chart (i.e. an Intraocular Lens (IOL) or a glaucoma valve or retinal gas). This is for recording (and for billing reasons in some countries). Some products come with a sticker containing the barcode and other details. If stickers are available, place on the surgeon's or OT notes and in the OT log-books. This will help with re-ordering and patient record keeping.

Preference lists: In order to know which equipment is needed for each surgery, always check the surgeon's Standing Orders or preference card. An example of the card is attached in Appendix B.

Safe Site Surgery: Reminder - Always check equipment and prosthetics during Sign-In, Time-Out and Sign-Out. This needs to be routine to ensure everything is functioning and ready, and to ensure damaged items and equipment are removed from service immediately. Please see section 1 for information and Appendix B for an example.

Retinal gasses and use

Retinal gasses are used during vitreo-retinal surgery. They are available in both individual-single form and in a multi-use re-fillable cylinder. Cylinders need to be treated in the same manner as other gasses.

When using gasses, sterility needs to be maintained when transferring to the sterile field.

Depending on the surgeon, the scrub nurse may need to calculate the concentration of gas to filtered air. This depends on the size of the syringe. To do this, another staff member must witness how much gas is taken and how much filtered air is taken. Together they confirm the concentration percentage with the surgeon before handing it over.

Ensure the recovery nurse is aware that gas has been inserted into the eye so they can provide appropriate post-operative education.

In some countries, patients are discharged with coloured wristbands, indicating that gas has been placed inside their eye. This is to alert other healthcare professionals (mainly anaesthetists – who use gas during anaesthetic care) in the event the patient is admitted unexpectedly for other surgeries.

Glaucoma valves

Glaucoma valves are stored as shelved, sterile items. They are generally opened in the same manner as a peel-pouch item. If using a tube and valve, ensure that the surgeon has checked the brand compatibility. Also ensure that there are children and adult sizes available.

Oculorplastic extras

Oculorplastic extras are very similar to other peel-pouch items in their care and handling, though be aware that some grafting material may be obtained from an animal product (i.e. swine/bovine). This is safe to use and poses no health threat, however for ethical religious reasons, some patients may not feel comfortable with these products being used unless informed. Therefore, if possible, always try and have an alternative graft material available so there are options available to the patient, and/or inform the patient at point of consent.

Sutures

There are a variety of suture types available. Types vary based on:

- needle: size, length, curvature, and angle of blade
- suture: material type, strength, length, weave (i.e. platted), absorbability and memory.

Always check with the surgeon before opening a suture because they are very expensive. Some rules to help guide decision-making are:

- The number on the packaging refers to the size of the needle.
- The higher the number the smaller the needle,
 - note: a lot of higher numbers (10/0) can be found in intraocular surgeries and lower numbers (5/0) in extraocular surgeries.

- Determine if the suture needs to “stay” in the patient or is dissolvable.
- Sutures called “Cat-Gut” are often preserved in an alcohol. The scrub nurse needs to rinse off the alcohol before handing to the surgeon.
- Determine if the surgeon is seeking to pass the needle through tough skin or the delicate eye. This will help determine the angle and type of the needle required to cut through the tissue.

Please see Table 6.1 from Aerolab for an example of needles and sutures commonly used in ophthalmology.

Reminder: Always count suture needles during time-out and sign-in, and every time a new one is opened. Place surgeon suture preferences on their preference card.

Intraocular lenses (IOL)

There is a wide variety of IOLs currently available. This can make selection confusing.

Some are for anterior placement and some are for posterior placement. Some are yellow for UV light protection and others are for refractive correction. Some are produced to be inserted flat while others are produced to be folded. Modern folding IOLs can also be supplied with injectors.

The surgeon determines the type and strength (dioptre) of the IOL based on the biometry. They also consider other ocular issues to determine where to place the IOL and which type.

From the nurse’s perspective, the IOL needs to be confirmed during all stages of the SSS checking process. The selected IOL needs to specifically match the surgeon’s request. If this is not possible, then the surgeon needs to be notified as soon as possible before surgery so that an alternative can be arranged and/or surgery postponed, until the desired IOL is ready.

Only nurses competent at folding the IOL or filling injector cartridges should prepare the IOL. The IOL needs to be inspected for damage to prevent damaged IOLs being inserted into the eye. The surgeon needs to be notified of any broken or damaged (scratched) IOLs prior to folding or placement in the injector.

Please see Tables 6.2 for the Aerolab IOL examples - PMMA hydrophobic and hydrophilic lenses.

References

1. Gould, R. Gordon. The LASER, Light Amplification by Stimulated Emission of Radiation, as cited in Franken, P., & Sands, R, H. (Eds). The Ann Arbor Conference on Optical Pumping. The University of Michigan. 15 June - 18 June, 1959; page 128. OCLC 02460155.
2. Australian Radiation Protection and Nuclear Safety Agency What are Lasers? 2016. www.arpansa.gov.au/radiationprotection/basics/laser.cfm. Accessed 06.06.2016

Table 6.1 Sutures





























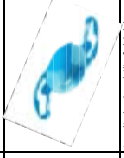

Brand Name	Aurosilk	Auroilon	Aurobond	Aurolene	Polyglycolic Acid
Suture Material	Silk 	Nylon 	Polyester 		
Available Sizes	8-0, 6-0, 4-0 8-0 - Cataract Surgery - ECCE, SICS (If Reqd) 6-0 - Orbit & Oculoplasty 4-0 - Orbit & Oculoplasty (Taper Point Needle) Rectus retraction in SICS (Conventional cutting)	10-0, 9-0, 8-0 Cataract Surgeries - ECCE, SICS (If req) Corneal transplant Surgery Keratoplasty	4-0, 5-0	10-0, 9-0	10-0, 8-0, 7-0, 6-0 10-0 ECCE, SICS (if reqd) Preferably for pediatric cataract surgery; 8-0 Glaucoma Surgery, Orbit & Oculoplasty; 7-0 Retinal surgery, Glaucoma, Orbit & Oculoplasty, 6-0 Corneal, Pterigium, Orbit & Oculoplasty,
Applications in Ophthalmic Industry			Scleral buckling surgery	Scleral Fixation surgery	
Model Nos.	8-0 - 8481S, 8482S, 8481VS, 8482VS, 8482VSB 6-0 - B610S, B6106 4-0 - B4401, B4203	10-0 - 6401N, 6402N, 6601N, 6602N, 8401N, 8402N, N0204 9-0 - 6491N, 6492N, 6692N, 8491N, 8492N 8-0 - 8481N, 8482N	5-0 - E5101, E5102, 4-0 - E4101	10-0 - 6002PP, 60602PP 9-0 - 6092PP, 60692PP	6-0 - A6108 ; 7-0 - A7102; 8-0 - A8104; 10-0 - A0101
Packaging	Pack of 12 foils per box	Pack of 12 foils per box	Pack of 12 foils per box	Pack of 12 foils per box	Pack of 12 foils per box
Carton Box					
Suture Needle (Medical graded stainless steel)	Spatulated Needle 	Taper point Needle 	Conventional cutting needle 	Reverse cutting needle 	

Table 6.2 Lenses

Brand Name	Hydrophobic				Hydrophilic				PMMA			
	Aurovue EV Preloaded	Aurovue	Auroflex Toric	Auroflex EV	Auroflex	Vision	Trueedge Aspheric	Aurogold	Aurolorens (PC Lens, AC lens, Scleral fixation IOL, Pediatric IOL, Negative power IOL, Low power IOL, Three piece IOLs)			
Image												
Material	Acrylic Hydrophobic foldable	Acrylic hydrophobic foldable	Acrylic hydrophilic foldable	Acrylic hydrophilic foldable	Acrylic hydrophilic foldable	Acrylic hydrophilic foldable	PMMA (non foldable)	PMMA (non foldable)	PMMA (non foldable)			
Material make	Manufactured by Aurouva	Manufactured by Aurouva	Imported from USA	Imported from USA	Imported from USA	Imported from USA	Imported from UK	Imported from UK	Imported from UK			
Optic design	Aspheric optic (Negative Aberration)	Spherical optic	Toric optic	Aspheric optic (Negative Aberration)	Aspheric optic (Zero Aberration)	Aspheric optic	Aspheric optic (Zero Aberration)	Spherical optic	Spherical optic			
Material nature	Flexible	Flexible	Flexible	Flexible	Flexible	Flexible	Rigid	Rigid	Rigid			
Haptic design	Force enduring haptics	Force enduring haptics	Dual haptics	Dual haptics	Dual haptics	Dual haptics	Dual haptics	Dual haptics	Dual haptics			
Square edge Design	Yes	Yes	Yes	Yes	Yes	Yes	Yes	Yes	No			
Reduces PCO rate	Reduces PCO rate	Reduces PCO rate	Reduces PCO rate	Reduces PCO rate	Reduces PCO rate	Reduces PCO rate	Reduces PCO rate	Reduces PCO rate	Reduces PCO rate			
Inclision size	2.8 mm	2.8 mm	2.8 mm	2.8 mm	2.8 mm	2.8 mm	5-6 mm	5-6 mm	5-6 mm			
Injector & Cartridge	AC28 PLI (preloaded)	C200 D1100/AC28 D1100	C200 D1100	C200 D1100	C200 D1100	C200 D1100	NA	NA	NA			
Endotoxin Level	less than 0.06 EU/lens	less than 0.06 EU/lens	less than 0.06 EU/lens	less than 0.06 EU/lens	less than 0.06 EU/lens	less than 0.06 EU/lens	less than 0.06 EU/lens	less than 0.06 EU/lens	less than 0.06 EU/lens			
Bio compatibility	Highly biocompatible	Highly biocompatible	Highly biocompatible	Highly biocompatible	Highly biocompatible	Highly biocompatible	Highly biocompatible	Highly biocompatible	Highly biocompatible			
Carton Box												

SECTION 7

Instrument and Equipment Sterilization Services.

Contributors: Heather Machin



This section will explore the sterilization and disinfection of instruments. Explanations on a wide range of methods will be outlined, to help facilities make an informed decision regarding practice within their facility. While costs and long term sustainability will be addressed, this section emphasises the importance of uniformed and safe practice, designed to ensure good patient outcomes and prevent infection.

Principles of Care

Principles of re-processing and micro-organisms

Ophthalmic instruments are small, and those used intra-operatively are often referred to as micro-surgical instruments. These instruments are extremely delicate and expensive, and require adequate time for thorough cleaning and sterilization (Marsden, 2014). Each healthcare setting that provides surgical procedures (including minor-operations), require policies, processes and compliance with sterilization standards.

Compliance with regulations is also important. Within Australia (and New Zealand), for example, all cleaning and re-processing of re-usable instruments, are governed by Standards Australia and Standards New Zealand. Their Standard is called the 2003: ANZ4187 Standard: Cleaning, disinfecting and sterilizing reusable medical and surgical instruments and equipment, and maintenance of associated environments in health care facilities (ANZ4187). This standard is collaboratively agreed and endorsed by professionals including - the Australian College of Operating Room Nurses (ACORN), the Australian Nurses Federation (ANF), the Australian Medical Association, and the Royal Australian College of Surgeons. This is widely supported by the state health departments and is used as 'the' benchmark for instrument care evaluation, within all clinics, hospitals and day-surgeries.

Tip: Always find out if there is a national or regional recommendation available. This is important because it will be written in consideration of the types of equipment, technology and cleaning products that can be obtained routinely within the country/region.

The bugs and preventing the bad stuff

This Section will predominantly discuss preventing cross-contamination of micro-organisms and the prevention of toxic exposure - and the trigger of an inflammatory reaction within the eye (Dinakaran & Kayarkar, 2002). Such distressing and well documented, post-operative complications, that need to be prevented, include; endophthalmitis and Toxic Anterior Segment Syndrome (TASS) - both discussed in Section 3), HIV (Human Immunodeficiency Virus) and, for those predominantly living in the western world, adenovirus type 8, for patients with a weaker immune system, and Creutzfeldt-Jakob Disease (CJD) - which is a life-threatening disease.

Infection clusters

Issues such as TASS may not only affect one patient but could affect several patients when identified as cluster outbreaks. These need to be reported immediately, by the treating surgeon to the sterilization and OT teams. When encountering a cluster, more quantitative guidance is needed (Anderson et al, 2005) by the multidisciplinary healthcare team, inclusive of the infection control nurse and microbiologist. This means that a microbiological examination of the environment and practices within the OT, sterilization rooms and the out-patient clinics are reviewed for avenues of possible transmission. At times, closure of the OT may also be mandated until all tests and possibilities have been exhausted. A standard investigation may include reviewing the sterilization department, OT practices, the specifics of the individual patient and their presentation etc. A review of the sterilization tracking records may also be required.

CJD: While CJD may not be widely known or experienced in lower resource locations, it is included in this text book because it provides context as to why many parts of the world advocate for single-use only instruments and very strict instrument cleaning protocols. Knowing about this disease will provide an understanding of why some of the Western policies are written in the way they are.

While the risk of transmission of CJD by surgical instruments, is likely to be low in eye care, given the very few transmissions reported following neurosurgery, CJD transmission cannot be excluded (Armitage et al, 2009), and consideration for instrument care or single-use alternatives needs to be discussed by each facility.

Debris

Inflammation may also be caused through retained debris on the instruments, such as cotton-fibres (Dinakaran & Kayarkar, 2002) left over from cotton-buds (cotton-tips). Care to remove the debris is needed.

Additionally, silicone oil used during retinal surgery, and viscoelastic used primarily in cataract surgery, also have the potential to remain inside the instrument and need to be removed prior to re-processing.

If the sterilization department, OT staff or surgeon are dissatisfied with the removal of debris from certain items, then discussions regarding single-use alternatives are required.

Sterilization departments have a duty of care to ensure that their facility is taking all possible steps to ensure compliance with best standards and risk prevention.

Department Design

Design of the sterilization department is important. Not only for the work-flow and quick turn-around of instruments, but also for infection control, employee ergonomics and to promote a comfortable workplace.

Importantly, facilities which provide other surgical services (i.e. dental, endoscopy, orthopaedics or general surgery) need to ensure barriers are in place to protect the eye instruments from contamination. They may ideally (space depending) include a segregated eye-instrument cleaning and processing area.

At no stage should cleaning brushes and syringes be used on anything other than eye instruments.

Segregation of dirty, clean and storage areas are also needed to ensure a clearly defined work-flow area, from dirty-to-clean. This prevents cross-contamination and confusion between the processing stages. This is achieved by the development of individual rooms for each stage of the process, and each with a door segregating the areas (see Figure 5.1 in section 5).

Controlled airflow is also important to ensure the prevention of cross-contamination. Within each area, airflow systems are recommended. For example, within the dirty room, a negative air flow is required, while in the clean area, a positive air flow is required. This allows the bacteria, particularly in the clean room, to be pushed out of the area - and in turn, prevents bacteria entering the room. These airflows are often supported by High-Efficiency Particulate Air (HEPA) filters and lamella flow systems.

The processing-flow of instruments into and out of the area needs

to be maximized for efficiency and to reduce work related injury to staff. Consideration is needed regarding:

- bench height
- distance to each section
- ease of manouverability within the area
- “dirty” access corridors for OT staff to transfer the contained instruments to the dirty sterilization room for decontamination.

Other issues to consider include:

- plumbing of filtered water and waste-water exit points - especially when using plumbed-in sterilizers
- strength of the floor to hold a full floor-to-ceiling sterilizer
- door width
- material used on the finish (i.e. non-slip continuous linoleum flooring to prevent both slips and corner areas (where the linoleum creases) for bacteria build-up)
- placement of power plug outlets for equipment - with consideration for prevention of wire damage and water damage (and electrocution)
- monitoring the humidity and temperature, especially in the instrument storage area.

The equipment

Most sterilization departments, at the very least, house decontamination areas (manual or automated), ultrasonic cleaners, driers, sterilizers and incubators to provide basic levels of service.

Cleaning area (manual or automated)

The cleaning of eye instruments and accessory items may be conducted through an automated instrument washer that is approved for eye instruments, or by a traditional manual hand washing process. Regardless of the system used, the facility needs to ensure competency processes are in place to promote uniformity in staff instrument cleaning practice. Regardless of machine or manual wash, the process remains the same. Instrument decontamination includes:

- checking all instruments have been returned from the OT after use - using an instrument tracking sheet (template provided in Appendix B)
- examining instrument integrity looking for damage, stiffness, and scissors being blunt
- soaking for a minimum of two to three minutes
- washing with decontaminant, and using brushes
- rinsing.

This initial cleaning phase is THE MOST IMPORTANT part of the instrument cleaning process.

Cannulated instruments: All instruments that are cannulated – meaning that they have a hole running through them, need to be cared for in a special way. They need to be washed, brushed and flushed, and brushed again, prior to being placed into an ultrasonic or washer, and then thoroughly rinsed and dried, before being placed into the sterilizer. This is to prevent any debris accidentally being injected into the eye of the next patient by the surgeon. Rinsing and drying is important to prevent the instrument from corroding internally – which not only damages the instrument but could cause leaking of potentially damaging material such as copper into the eye.

If there are cannulated instruments that cannot be cleaned internally, then change brands or revert to single-use only. The rule is – if it cannot clean, rinse and dried inside, then it is not clean!

Ultrasonics

Ultrasonic machines are essential for cleaning metal items. They help to remove (blast) any remaining particles from the surface of metal instruments. They use ultrasonic sound waves (between 20-400 kHz) via a process called cavitation and implosion. This means that “waves” of acoustic energy disrupt the bonds that hold particulate matter to surfaces (Center for Disease Control, 2008).

It is essential that facilities, providing other surgery types, provide a separate ultrasonic for the eye instruments, to prevent cross-contamination.

All machines need to be set up and checked before use. All machines should be filled with distilled water to the water mark line, and then the instrument cleaning fluid of choice is added. To test the machine, proceed as below:

- **De-Gas Cycle** - Most machines have this function. (Check the manufacturer’s recommendation on how to de-gas the machine). De-gas helps to settle the water and remove gas.
- **Test to see if it is working** - There are several ways of doing this. Some companies supply small test cards which are placed into the ultrasonic. The test cards change colour when the machine is working correctly. This method is very popular in many countries though requires an ongoing cost-commitment to purchase the cards. Cheaper options are to mark a specifically designed material with a special pencil (Hendricks test) – when the pencil mark is removed, it means the machine is working. The Hendricks test is a cheaper method though not always easy to purchase. Lastly, specific metal disks or aluminum foil can be used in a similar way to the Hendricks test by placing the mark on these cheaper items.

Driers and air guns

Driers are required to ensure that instruments are completely dry prior to wrapping and placement into the sterilizer. Driers need to be safe for the user, prevent burns, and are enclosed, to ensure the instruments are protected and provided with concentrated heat. All driers require a filter system to prevent external air-particles from being sucked into the machine and blown onto the instruments. Staff would be wise to wear heat resistant gloves when removing items from driers. This will prevent burns.

Airguns are attached to filtered air that is attached to a tube and a small nozzle trigger-gun. The nozzle can blast air through the cannulated instruments at great pressure.

In some countries where driers are not available, domestic hair driers are used instead. While the hair drier is not ideal, if the facility insists on using one, please keep in mind that they:

- can overheat. This causes them to be a fire hazard – have them checked regularly
- should not be left turned on and left lying on the bench/mats because of their fire hazard
- should not be plugged in close to the water supply (prevent electrocution)
- may unknowingly blow dirty air onto instruments
- will not clean inside cannulas – a large syringe full of air will still be needed to blow out remaining liquid.

Sterilizers

Steam based autoclaves (self-closing) sterilizers, were invented by Charles Chamberlain, a microbiologist who worked with French microbiologist and chemist, Louis Pasteur, in the late 19th

Century (Ahuja, 2011). Sterilizers remain the main component of sterilization within modern hospital facilities, as they provide a controlled and concentrated 'pressure' chamber (ANZ4187, 2003). This pressure creates a sealed chamber which allows for instruments to be penetrated, by the steam, for a specific duration. Depending on the machine, this may be 121-134 degrees Celsius, between 5-13 minutes, plus dry time and de-vacuum (de-vac). For eye instruments, purchase a sterilizer which will allow for a 134 degree Celsius heat mode. In the past, people worried that this temperature was harsh on eye instruments but this is not correct. 134 will not damage instruments. If an item is damaged during any type of sterilization process (i.e. melts), then that is an indication that the instrument was not designed to be re-sterilized and should be discarded.

There has been much change in the marketplace since the first edition of this text book and several methods are now no longer recommended due to the potential damage and harm that they can cause. Additionally, there has been a move away from heat sterilizers. Predominantly steam autoclaves are currently considered the gold standard for ophthalmic surgeries, and they are readily available in most countries in stand-up, bench-top and mobile machine design styles. They are also available as either a manual control or an electronic programmed machine.

For the purpose of this text book, we will predominantly discuss steam sterilization.

Flash sterilization

Over the past ten years there had been a trend towards flash sterilization (which is a programme designed to sterilize the instruments very quickly). Now, however, the trend has reversed, due, in part, to the over use of the technology by those involved in the processing - whereby instruments were routinely placed in the flash but not receiving a full sterilization. Currently, it is recommended that flash sterilizers are removed. If they must be kept and used, due to resource limitations, then ensure they are only used for emergencies or for items dropped that require a quick turn-around, and never used for cannulated items.

Additionally:

- keep a record of use as evidence of which items require purchasing, in order to reduce use
- ensure the flash sterilizer is checked and tested as per the manufacturer's recommendations.

As an example of recommendations, the Australian ANZ4187 Standard (2003) states that:

- The use of 'flash' sterilizers shall be restricted to situations where a single instrument has been dropped and there is no sterile duplicate available.
- Cannulated, complex instruments, suction and other tubing shall not be processed by this method.
- This type of sterilizer can only be used for unwrapped, non-porous items. It will not dry the load; therefore textiles and paper shall not be used.
- The instrument 'flash' sterilizing process shall be monitored to ensure efficacy.

Notes:

1. The use of 'flash' sterilizers as a convenience or as a cost saving mechanism is not acceptable. Having an adequate supply of instruments is more appropriate.
2. 'Flash' sterilizers are not designed to sterilize liquids, and therefore sterilization of liquids should not be attempted.

Where other types of sterilizers are used as instrument 'flash' sterilizers, the principles in this. Clause continues to apply.

WARNING: THERE IS DANGER OF CONTAMINATION OF UNWRAPPED STERILIZED INSTRUMENTS IF THEY ARE NOT USED IMMEDIATELY AFTER 'FLASH' STERILIZATION. (ANZ4187, 2003).

Selecting the sterilizer - benchtop or stand-alone

There is no difference between benchtop, stand-up or mobile sterilizers. The real difference depends on the volume of surgery being performed (i.e. how much each load needs to carry). When purchasing a new machine, keep in mind:

- Its weight - can the bench/floor support it? Can staff easily access the chamber without getting burnt?
- Entry and exit points for filtered water - can staff reach these points safely, or can it be plumbed in so staff do not need to worry about water exit and entry?
- Heat generated - where is the vent? Make sure the vent is not covered. Efforts must be made to expel the heat from the room, otherwise the area may become uncomfortable to work in and/or could increase moisture in the air.
- What classification is the sterilizer? Not all sterilizers are designed to do the same thing. Some are adequate for dental or beauty salons but not for surgery. Therefore, before purchase, ensure the machine is safe and acceptable for surgical instruments - and in particular, ophthalmic instruments.

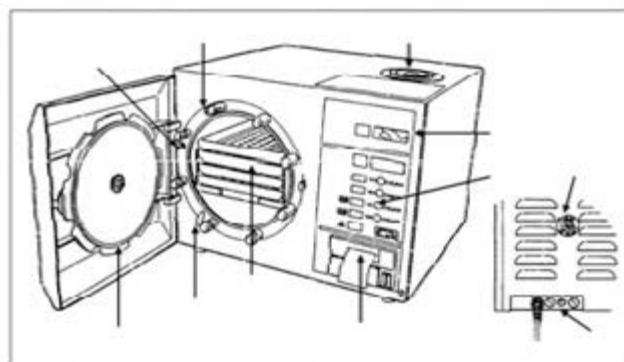

Testing the Sterilizer

Regardless of the type of sterilizer, it will need to be checked daily (excluding days when the facility is closed). This can take place anytime in the day, but best practice (and practical sense) suggests that it is best done every morning before the commencement of surgeries. This allows time to trouble-shoot issues before the day gets busy. Sterilizers need to be tested, and this can be done in several ways, such as:

Chamber check

It is important to check that the chamber - where instruments are placed - can actually close completely. This is because heat can only be created if it cannot escape. The aim is to make sure that heat stays in the chamber for the time required. Any leaks will mean the temperature cannot be maintained long enough - and thus the instruments are not being sterilized. To perform a chamber check, turn on the sterilizer, first thing in the morning, to let it heat up. Then place it on either a normal cycle or a "pre-vacuum" cycle (depending on the machine). Do not put anything in the machine other than test cards. In order to test if the machine is working.

Depending on the machine, complete the vacuum-test at the beginning of the day (some machines prefer this done on a cold chamber, while others will prefer this on a warmed-up chamber. Find out what works best for the specific machine).

Print-out results

Some machines have a print-out receipt outlining the machine's parameters. Specifically the print-out documents the temperatures that the machine reached at each stage in the cycle. A print-out can be produced for each sterilization load and retained as a record of sterility.

If a print-out option is not available on the machine, stay close by and watch the monitor/gauge to see if the temperature is increasing and decreasing, as expected.

Steam distribution check

It is important to check that the sterilizer is providing an equal level of sterilization to all parts of the chamber – not just one side or the other. To do this, a tester is placed inside the chamber so a test load can be carried out. There are lots of methods to do this, for example a test-card or a test-cylinder. There are many brands on the market. One of the most commonly referred to brands is the Bowie Dick Test. This test is used to detect trapped air in pre-vacuum assisted type autoclaves. It is a standard operational test that helps to establish if air is being distributed and removed correctly (3M, 2010). All of these systems have similar principles whereby the test cards are placed inside a pre-designed wrap or cylinder, or pinned to the racks, and then placed into the sterilizer on a normal cycle. The aim is that the test cards will change colour, (i.e. from white to black) in an even colour distribution – without faded parts. If the whole card changes colour then the machine is working well. If only a part changes, or if there are variations in the shade of the colour then the machine is not evenly distributing steam. That means that instruments placed in those parts of the machine may not receive full steam penetration.

A cheaper way to do this – if pre-made test cards are not available – is to fold 12 drapes and place a cross of autoclave tape on the 12th drape. Place another 12 drapes on top, tie the bundle with string and place it in a drum, in the autoclave, to go through the full cycle. After the cycle, open each item to ensure the autoclave indicator tape has changed colour.

Killing bacteria checks

Finally, it is important to make sure that the sterilizer has the capability to kill all known bacteria (with the exception of CJD which cannot be killed in the sterilizer). To do this, complete a biological (Enzymatic) test. This differs from other types of tests and requires the purchase of small disposable bacterial-spore test (BST) vials and an incubator that is compatible to those particular vials. This is how testing takes place:

- Place one bacterial-spore test (BST) into a peel-pouch and place it in the sterilizer on a normal cycle. Mark this with a number or letter (i.e. 1 or P for primary).
- When the load finishes, remove the BST from the peel-pouch.
- Place the primary BST into the incubator as instructed by the manufacturer.
- Place a second BST (one that was not put into the sterilizer) next to the primary BST in the same incubator. Give this a number or letter too (i.e. 2 or C for Control).
 - Depending on the system purchased, “Crack” both BST P and C vials by squeezing them through a specifically designed vise attached to the incubator. Prior to placement, ensure gloves and goggles are worn. This is

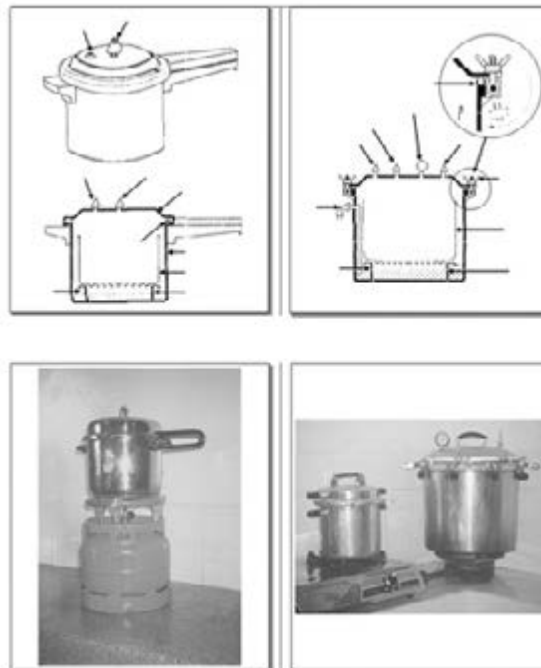

because C will still contain live-spores, and P may or may not still contain live spores – depending on the success of the sterilization.

- Once placed into the incubator, set the machine to “cook” both the BSTs, for the time period recommended by the manufacturer (i.e. 3 hours). After that time, the machine will indicate if BST P and/or C are negative or positive to living-spores. It is expected that the C will still have live spores as it was not placed in the sterilizer, while the P will not have live spores because the sterilizer killed the spores. If P still contains live spores then this indicates that the machine did not kill the bugs.

If any/all of the tests fail to give the result outlined above, then that could be an indicator that the machine is not functioning. If so, complete a second or third test, just to be sure. If it continues to fail, then call the biomedical engineer for an urgent review. Place a ‘Do-Not-Use’ sign on the machine until the biomedical engineer has investigated the issue. Always inform the OT manager and other members of the OT team so they are aware of what is happening. The team may need to make other arrangements if the sterilizer is out of action too long.

Preferably these tests should be performed on every sterilizer and ultrasonic, every workday. The cost for doing this however may be outside of the budget. Therefore, if daily testing is not possible, then, strive for weekly, and build up to daily.

Water

As certain types of water can cause ineffective cleaning, and can even damage the instrument and machines over time, special care is needed to make sure the right kind of water is used in the right way and at the right time.

Preferably piped-in water is best. It is even better if this can be filtered several times before reaching the tap because normal town water can harbour contaminants that could be harmful to people and instruments. Additionally, the acidic/pH level varies and that could also damage instruments long term and cause toxicity to the eye. Therefore, routine pH testing is recommended for irregular water supplies, and is mandatory for mobile health facilities which use different water supplies at each location.

If using rain or tank water, keep in mind that tanks can also harbour nasty bugs too and can attract mosquitoes. If using rain water, make sure the tank is regularly maintained and tested, and the water is filtered. Boiling is also good but this may not be enough. Therefore, always filter beforehand, to ensure the cleanest water possible is provided.

Water types

Normal tap water is fine for hand-washing and regular cleaning - assuming it is filtered however distilled water is advised for instrument cleaning, rinsing and for placement into the sterilizer and ultrasonic. This is performed via:

- **Automatic fill** - some sterilizers and ultrasonics on the market allow for the machine to be directly plumbed into the building's water supply. This is a preferred option - assuming it is tested and filtered. It prevents staff from having to fill and change the water in the machine. Ultrasonics with this system will still need staff to open and close the exit valve to remove old water.
- **Manual fill** - if the ultrasonics and sterilizers are not used often - make sure water is removed from the chamber to prevent grime accumulating and damaging the machine. At the very least, check the machines weekly.

Making water

Special water (i.e. distilled) can be purchased. It can also be produced by the facility if the correct set-up is available. To do this, filters and distillers are required.

- **Filters** - Filters can be built into the pipes or screwed onto faucets (taps) so that every time the tap is turned on, filtered water is provided.
- **Distiller** - Mobile, plumbed-in, and bench-top distillers are very easy to purchase. Depending on the machine, it may take 1-2 hours to make 1-2 litres. These machines are effective but they do require budgetary commitment to purchase the re-fill filters. Distilled water is essential for several steps of the sterilization cleaning process.

Note: it is best to avoid using or soaking instruments in saline as the chloride ions are highly caustic and can cause pitting and deterioration of instruments (Tauras, 2013).

Testing faucets (taps)

In some countries, hospitals are required to test that the faucet (taps) and other parts of water storage tanks and pipes are not contaminated. Check local recommendations for testing recommendations.

Cleaning Solutions

Cleaning solutions are designed, with combined inert and active ingredients, to work together to remove soil and debris from the surface of the instruments. These solutions may include surfactants (surface active agents which act as detergents and aid the cleaning process), solvents, and enzymes to ensure that a clean broad spectrum clean, against dirt particles, is provided (Root et al, 2008). There are lots of cleaning solutions on the market and there is wide and varied access to different types across the world.

Selection primarily comes down to what is accessible. Some key basics to follow are:

- Avoid household domestic solutions because they have not been tested as safe for healthcare and specifically the eye.

- Select solutions that are designed as safe for use on eye instruments - check with the manufacturer.
- pH neutral - this will ensure it is gentle on the instrument and the eye.
- Not harmful to the user.
- Not too bubbly - this will make it harder to rinse off.

WARNING: Avoid anything that contains Glutaraldehyde as this is dangerous to the worker and is potentially dangerous to the eye if the instrument is not rinsed correctly. Over the past 10-15 years this product has slowly been removed from practice in a variety of surgical specialty areas. Also check that it is not an added ingredient of another product. If unsure, ask the manufacturer if the solution contains Glutaraldehyde or a similar agent.

Decontaminants

Used for the manual cleaning of instruments to decontaminate them, these solutions need to be of a pH neutral base. Follow the basic principles outlined above for selection. Often decontaminants are referred to as detergents - which is a generally acceptable term in common speech, but can be confusing because the term detergent can be associated with a much more bubbly and oily product, i.e. dishwashing liquid use to wash dishes at home.

Enzymatic cleaners

These protein (amino-acid based) and pH neutral solutions are preferred because their 'reaction' is to push the molecules (soiled materials) off the instruments. This can be achieved with little force, by the operator, by using gentle brushing, and is suitable for the delicacy of ophthalmic instruments. It is enough to remove organic matter, and is used as a pre-soak during manual cleaning of delicate items, and as the first stage of most automated washer processing cycles (Root et al, 2008).

Ultrasonic cleaner

Common in some countries, a specific solution can be purchased and placed into the ultrasonic to help clean the instrument and promote cavitation (the formation of bubbles to aid separation of particles from the instruments). Such solutions are not readily available all over the world. While it is preferred to use an approved solution to ensure a complete clean, the ultrasonic can still be used without it to remove gross matter.

Lubricants

Lubrication is required for hinged or other metal contact items (e.g. nut and bolt or screwed in sections). It allows the instrument to manoeuvre smoothly and effortlessly.

Lubrication: There is much difference around the world regarding the frequency of lubrication. Some facilities lubricate after each use, and to all instruments, while others lubricate at regular intervals (e.g. weekly). To determine best practice, consult hospital policy, and state/national guidelines. (Henning, 2011.)

Australia's ANZ4187 (2003) which states that:

"If lubricants are required, they shall be water miscible, be compatible with the sterilizing agent and used in accordance with the manufacturer's instructions. Lubrication shall not be regarded as a way of overcoming inadequate cleaning practices. Routine lubrication of instruments following the cleaning process can lead to extremely heavy contamination. Stiffness of instruments may be due to 'flash' sterilization, exposure to saline solutions, inadequate cleaning or misalignment and will not be corrected by lubrication. Where lubrication is used, the lubricant solution should be discarded after each use. In certain geographical areas, mineral

deposits from water may present serious problems regarding the effective functioning of instruments. This may be rectified by appropriate water treatments.”

Alcohol

It is recognised that in several parts of world, that alcohol is routinely used as an effective general cleaning product because of its many broad spectrum benefits and availability. Over all, when discussing alcohol in the context of ophthalmic surgical instrument processing (which is different from wiping down office-based instruments such as tonometers), then alcohol is an option but not the first option because many of the newer decontaminants can clean just as well.

While no longer routinely used in the higher resource locations, some lower resource locations tend to favour alcohol for external plastics or materials that cannot be submersed (i.e. lenses) and because it is readily available and cheap.

If using alcohol, please be aware that it is a flammable liquid and safe storage is required.

While it would be preferable to purchase and use some of the solutions already outlined in this text, if there is nothing else other than alcohol, then it is better to use it rather than nothing.

Domestic/house-hold products

As already stated, at no time should domestic and household grade products be used on surgical instruments. This is regardless of listed ingredients. If this has not been approved for use on human surgical instruments, and tested as safe to do so, then do not use it. It could both degrade the quality of the instrument over time, and place the patient at significant risk of toxic exposure. Significantly, such toxins pose a serious risk for patients undergoing intra-operative surgery.

Solution concentration levels

Once the facility has decided on the solutions, the team will need to calculate how much of each solution is required for each cleaning bowl/ultrasonic etc. Refer to the manufacturer's recommendations or instruction label. Most likely it will advise to use a ratio based on so many millilitres per litre.

Once calculation has been determined, place the instructions on the wall within the sterilization room so staff can prepare the bowls in an identical fashion. They must all fill/mix the same amount of water to the same amount of solution as the instruction sheet requires. This is how uniformity can be maintained and the facility can confirm the concentration level is safe.

Setting-Up Each Day

Prior to accepting soiled instruments into the dirty area (room) of the department, the Sterilization Nurse or Technician (SNT), is required to prepare the area for the day. This includes preparation of the soaking, cleaning, rinsing and ultrasonic service areas, and machine testing.

Each morning, the SNT reviews the daily surgical schedule. They need to prepare the area and review workloads to ensure that instruments can be processed and ready for the day's surgeries. This may require the SNT to liaise with the surgical team - scrub and circulator - regarding their timeframe and needs.

All cleaning areas and machines need to be prepared, as per the facilities policy, and in a uniformed manner to ensure consistency of service - this means that every staff member needs to follow the same steps in the process. Validation pre-vac and sterilizer warm-

ups are also completed. This section provides a suggestion of set-up checks and items to prepare. Adapt this to suit the facility.

Dirty Area

- soaking bowl (if used)
- manual wash bowl with brush/cloth
- rinse bowl (if using bowl rather than a spray gun)
- ultrasonic:
 - de-gas cycle
 - cavitation test if available (i.e. Hendricks or foil)
- lubrication and/or enzymatic bowls if available
- alcohol (if using)
- air gun/drier/hair drier
- ensure preventative slip-mats are placed in sink/water areas to prevent slipping.

Check availability of:

- personal protective equipment: apron, eye-goggles, gloves
- hand soap or hand alcohol wipe
- sharps containers
- general and contaminated waste bags (and cytotoxic if available)
- laundry bags (if the sterilization team is responsible for collecting and sending used laundry)
- distilled water – think ahead to what is needed for the rest of the week and prepare ahead.
- check if your distiller filter is due to be changed.

Sterilizers

- check water chamber if not plumbed in
- turn on and allow the machine to warm up
- check ink and paper levels (if the machine has the print-out function)
- pre-vacuum test
- Bowie-Dick test
- biological spore test.

Wrapping and clean area

- check heat-resistant gloves are available to remove the instruments from the sterilizer
- hand soap or hand alcohol wipe
- wrap materials are ready:
 - paper or cloth steri-peel bags and wrap
 - indicator tape
 - tags
 - batch gun with stickers (if this is not available then just write the batch and load numbers on the tape)
 - batch log books
 - marking pen
 - internal universal indicators
 - instrument tip protectors (if available)
- cooling racks are available
- paper work print-outs are ready (we will discuss paperwork within the tracking section).

Surgical Instrument Familiarity

Before sterilizing the instruments, check their integrity and select the cleaning method. To do this, it is important to be aware of the material that the instrument is made of, and prepare for them accordingly.

Know the material

Table 7.1 outlines some suggestions on how to handle and care for instruments and equipment made from a variety of materials.

Material	Decontamination	Sterilization
Glass	Gently wipe over. Do not submerge.	Check that they can be placed into a steam sterilizer. If not they may need to be sent for Sterad.
Plastic	Can be submerged. Can be wiped over.	Can be placed in a steam sterilizer only if they are designed for re-sterilization. Melted, disfigured or discoloured plastic indicates that they should not be sterilized – throw them out.
Metal (all types)	Can be submerged, can be gently cleaned with a cleaning brush.	Can be placed in a steam sterilizer. Generally no issues.
Fibre-optic cables	Generally wipe over gently. Do not submerge. Do not allow connector end to get wet. Check surface integrity.	Can be placed in a steam sterilizer. Place the provided connector-cap onto the cable to prevent moisture. Be careful not to pack the cable too tightly as this might cause the fibres inside to break. It can also create kinks which can be annoying to the surgeon.
Electrical cables	Wipe over gently. Do not submerge. Do not allow any electrical connection points to get wet. Check surface integrity for exposed wires.	<ul style="list-style-type: none"> Can be placed in a steam sterilizer. Be careful not to pack any cables too tightly to prevent breaking the wires inside. It can also create kinks which can be annoying to the surgeon. <p>Note: any cable with exposed wires needs to be removed from service.</p>
Battery operated item	Wipe over gently. Do not submerge. Remove all batteries.	Ensure batteries are removed. Check the manufacturer's instructions regarding sterilization method.
Gem (Diamond) blades	These are very delicate. Do not touch the tip, wipe or brush them as this can damage the blade. Instead, use 'running water' (filtered) to clean the tip while it remains in its retracted position.	These are all made differently though most modern tips do allow for steam sterilization. Either way, check with the manufacturer's instructions beforehand.
Tonometer tips	In light of the tenacity of adenovirus type 8 (experienced more so in higher resource countries, the Center for Disease Control and Prevention and the Association for professionals in Infection Control and Epidemiology (USA) have recommended that "tonometer tips be cleaned with soap and water and then disinfected by soaking them for 5 to 10 minutes in a solution containing either 5,000 ppm chlorine, 3 % hydrogen peroxide, 70 % ethyl alcohol, or 70 % isopropyl alcohol" (as cited in Charters, 2006).	Not required as the Tonometer is used in the clinic. If the surgeon does want to use it in the operating theatre, they will be using it before surgical preparation, so it should not compromise the patient post-surgical preparation and is therefore a non-issue.

Table 7.1: Instrument and equipment materials

Instrument Style	Example	Preparation for cleaning and sterilizing
Hinged	Haemostat, scissor	If left in the closed position, water and detergent cannot reach all the surfaces of the instrument and a complete clean of the instrument has not occurred (Tauras, 2013). Therefore, un-hinge the instrument completely. Allow for the hinged area to be brushed. Also leave slightly un-hinged when sterilizing too.
Cannulated	Cystotome	If possible do not re-use cannulated items unless the item is specifically designed for re-sterilization. If they must be re-sterilized, then please make sure they are cleaned, rinsed and dried inside of the cannula. This is necessary to help prevent TASS. Note: If an item has a hole or tubing that cannot be completely cleaned through, then you may need to discuss changing to a single-use only item.
Screwed	Calliper, speculum	Un-screw until in a full unscrewed position. This allows the 'screw' area to be brushed over. Try and put back into its original position for sterilizing so it is ready for the surgeon.
Multiple-parts	Charles Flute cannula, Biom (Binocular Indirect Ophthalmic Microscope) viewing system	Always check the manufacturer's recommendations with multi-part items. Generally, unless stated otherwise, multi-part items need to be kept together in the same tray but separated and counted as separate items.

Table 7.2. Instrument types – and cleaning recommendations

Preparing

Before cleaning, it is also important to prepare the instrument in a manner which will allow as many of its surfaces to be cleaned and sterilized as possible. Here are some common items found in the facility.

Checking returned (used) instruments

Firstly, put on Personal Protective Equipment (PPE).

Start by completing a visual check to make sure that there are no sharps or hazardous materials in the instrument trays received from the OT. This is to prevent injury. If sharp items are found, remove and discard safely, as per policy. Also inform the scrub nurse because it is their responsibility to remove all sharps – it is important that this is prevented in the future.

Confirm that everything has been returned. For example, if the cataract tray has 20 items on it, check that 20 items have been returned from the OT. This needs to be done immediately to prevent instrument loss. The OT Team can then look in the OT, or the waste, to find the missing item. This is also to help confirm that the item has not been left inside of the patient. While it is unlikely to lose an instrument inside the eye, implementing an early checking system is good practice.

Lastly, check the integrity of the instrument to help prevent damaged instruments being used on the next patient. Ideally, the scrub nurse will identify instruments needing repair, however this does not always happen. Therefore the SNT must check each instrument themselves.

With some ophthalmic instruments, it can be difficult to examine them with the naked-eye. As a recommendation, use a magnifying lens, and ensure there is good lighting in the room in order to inspect the instrument's integrity and suitability for re-processing. (Henning, 2011)

Decontamination

Once the area has been prepared then the Sterilization Department is ready to receive instruments from the OT. The decontamination process can then commence.

This Section assumes manual hand-washing of instruments (rather than machine washing) occurs.

Personal Protective Equipment (PPE)

Wearing PPE is essential in the decontamination phase. This includes apron, eye-goggles and gloves. Non-sterile gloves are suitable. Ensure that they do not contain powder. If available, opt for long-cuffed gloves (mid-forearm) over wrist length as water notoriously trickles into wrist-length gloves.

Soaking (of metal instruments and outer trays only)

Soaking is not universal. Generally it is performed if the staff are unable to attend to the instruments immediately because soaking will prevent any debris from drying out – which makes cleaning harder for the SNT. A separate soaking bowl can be prepared or the instruments can be placed directly into the manual hand-washing bowl until the nurse is ready to perform the manual hand-wash.

Manual hand-wash

Once the SNT is ready to complete the manual hand-wash, all hinged and screwed items are opened and multi-part items are separated. A count of the instruments is also completed to ensure

everything has been returned. cleaning includes:

- **Metal instruments** - every surface of every metal item needs to be manually brushed with a tooth brush or wiped over with a non-lint wash-cloth. Cannulas also need to be cleaned inside with the decontaminant until no further debris is expelled – this can be done by using a large syringe filled with decontaminant-water from the wash bowl. They are then placed in the rinsing area.
- **Trays and bowls** - plastic and metal instrument trays or bowls can be submerged and wiped over with the cloth and placed in the rinsing area.
- **Other special instruments (i.e. glass, battery-operated, and electrical and fibre-optic cables)** - gently wiped over either with the decontaminant (and then wipe-rinsed) or wiped over with alcohol (depending on what is available and what is advised by the manufacturer). They are then placed in the drying area. Do not submerge.

Note: ensure that the cleaning toothbrush and cloth are of good quality and do not break apart. These should be discarded or washed at the end of the day.

Rinsing

Rinsing off solutions, such as enzymatic cleaners, is important as studies, such as those conducted by Parikh et al, 2002, on comparable rabbit corneas, identified that enzymatic cleaners can cause sensitivity and abnormal vascularization and dilated extracellular space, resulting in increased corneal permeability and oedema, and iris inflammation after intracameral injection.

If there is plenty of water available, the best way to rinse the instrument is by letting water fall onto the instrument (like a shower) so that the decontaminant literally drains off. This is the preferred method.

If water is an issue, use a rinse bowl. When doing this, be mindful that the water will need to be changed regularly to prevent the build-up of the decontaminant in the bowl.

All surfaces of metal instruments (and the plastic and metal trays and bowls) need to be rinsed.

Cannulated instruments need to be completely rinsed through with clean water and a syringe designated for rinsing. The rinsing continues until there is no further evidence of bubbles (decontaminant solution) exiting the cannula.

Drying

Preferably, instruments are placed in a hospital grade drying machine which will ensure the instruments are externally dried. As this may not be possible, the instruments can be air dried by placing them on top of an absorbable lint-free cloth. Providing all hinged and screwed items are open and all instruments are separated – not touching, then they can remain on the cloth until they are dry-to-the-touch.

All cannulated items will need to be blown through internally, via an airgun or an air filled syringe until there is no evidence of retained fluid.

Wrapping and Labelling

Once dried, and the integrity has been checked (Instrument Integrity is discussed in section 8) the instruments and equipment can be prepared for sterilization. Generally they are either wrapped in a low-lint cloth or sterilization wrap, or placed into a peel-pouch. Alternatively drums (plastic or metal) can be used. All methods are acceptable.

Size

Size is matched to the item/tray requiring a wrap. If it is too large, it will allow instruments to move around, pool steam/water, make it difficult to wrap, or make it difficult for the OT team to open.

Alternatively, if it is too small, it will not completely cover the items once wrapped/folded. Small peel-pouches, could also damage the packaging or the item inside.

Note: for peel-pouches, if too loose, it could result in the instrument being damaged

Before wrapping

- Ensure all items are accounted for.
- Check that all items are in good working order. Remove damaged items.
- Assemble as required.
- Place instruments onto trays or into sets as required – and place in a uniformed fashion each time (this helps the scrub nurse locate items quickly and helps everyone know if something is missing).
- If using a tray, use a rubber mat to prevent it from moving around. Leave space between each instrument in order to allow all surfaces to be penetrated.
- Place instrument protector tips onto forceps or sharp instruments (if available):
 - select packing type and size
 - place an internal universal indicator inside the packaging.
- Complete any instrument tray tracking lists (template provided in Appendix B).

Wrapping

The aim of wrapping is to make life as easy as possible for the OT Team, so that they do not drop the item when opening or waste time trying to work out what it is or how to grab-hold of it. The Sterilization Department is responsible for ensuring instruments can be opened effortlessly by the OT Team.

Materials

Wrap – cloth or single-use

- When wrapping, use two layers of cloth/paper in order to provide full sterile coverage.
- Either wrap these together in one step or as two separate wraps. There is no scientific reason why one method should be performed over the other, however, practice seems to favour the two separate wrap approach because this makes the wraps easier for the OT Team to open.
- The idea is to wrap the trays as tight as possible to prevent movement and pooling of fluid, therefore a specific 4-quarter method is used which folds like an envelope.
- Once wrapped, the instruments can be secured with the surgical indicator tape (Photo 7.1).



Photo 7.1. Wrap material. Folded over and secured with indicator tape. This photo also has an instrument tracking list. Tracking list templates are available in Appendix B.

Peel-pouch

- Double wrap peel-pouch (that is, a peel pouch inside another peel pouch) to help prevent damage and prevent them dropping if opened incorrectly. Routinely the double peel-pouch method is seen in most parts of the world (Photo 7.2).
- The aim is for the handle of the instrument to be presented to the scrub nurse so they are not grabbing at sharp and delicate instruments. Therefore, the SNT needs to insert the instrument backwards so that the handle is at the open-entry part.
- Once inserted, the pack can be sealed, either via a self-sealing mechanism on the packaging, surgical indicator tape or via a heat-sealing device.



Table 7.2. Example of peel-pouch (green) wrap. In this example, the instruments are protected by a tray, and then the wrap.

An instrument roll is a long peel-pouch roll which can be cut to size and then heat sealed. As a rule, when determining the size, check:

- The material is strong enough to hold the instrument – if not, place it on a tray.
- Will the instrument penetrate the material? If so, consider placing it on a tray or use a tip protector.
- Will the instrument get damaged in storage? If so, consider placing it on a tray or using a tip protector.

When selecting the size, ensure:

- It is not too tight to break the material or too loose (too loose will mean the instrument could move around and become damaged).
- Cords and fibre-optic cables are not kinked or too tightly packaged, as this may also cause damage.

Drums (metal or plastic)

Drums (Photo 7.3) can come in a variety of shapes and sizes. They can be used for multiple items or single tray sets. Regardless of what the drum is used for:

- Check that they are in good working order and the lid can be clasped firmly shut and any vents can be opened and closed.
- If the drum requires filter-vent-paper ensure that these are available.
- If the drum requires filter-vent-paper ensure that these are available.
- If using a plastic seal-clip, ensure that they are available.



Table 7.3. Drums. In this example, individually wrapped trays/items are placed into the drum for storage during sterilization.

Instrument trays

Trays are made of metal or toughened plastic (Photo 7.4) and can be boiled or autoclaved. Each slot holds one instrument - preventing instruments from touching one another. Trays:

- Have holes to allow for drainage of water.
- Must be dried well before the instruments are placed in them, as moisture will cause metal instruments to rust.
- Depending on the type and system, they can be self-contained or may need to be wrapped.
- Rubber mats can be used to place instruments on during surgery.
- Instrument protectors must also be used if the instruments are in trays.



Table 7.4. Instrument tray. In this example, the instruments are secured on a rubber mat. This tray is either placed into material wrap or a peel-pouch for sterilization.

Labelling

All items need to be labelled. This includes:

- name of instrument
- date of sterilization
- initials of person who wrapped them.

Ensure the label is placed on the top/front of the item so it can be quickly identified. Also write on the surgical tape (cloth/paper wrap) or plastic of the peel-pouch or use a specific durable label (some are specifically designed for sterilization). This is to prevent the pen ink penetrating the packaging during the steam process.

Any labelling stickers and/or instrument tray tracking sheets need to be placed on the outside of the packaging. We will discuss these shortly. An example of a tracking sheet can be located in Appendix B.

Sterilization Procedure

Once the sterilizer has been tested and the instruments correctly wrapped, the sterilization process can occur. The first step is to “load” the sterilizer with all of the instruments. Some general rules for loading are:

Do not

- overfill the chamber
- allow surfaces of items to touch each other (if possible) in order to ensure the steam can completely penetrate the area
- stack trays on their side – this may dislodge the instruments and damage them
- put all the heavy trays/instruments on the same shelf – this will make it difficult to pick-up or move.

Do

- use metal racks to help maximise the space
- place heavy items on the bottom and lightest at the top
- place individual peel-pouch items on their side via a rack, if a rack is available
- place peel-pouches, facing downwards when placed flat. This allows the steam to escape via the paper side
- distribute the weight across the chamber to make it easier to remove when they are hot
- check that each item has been labelled correctly, prior to

- placement in the chamber – including a universal indicator
- place bowl/dish sets upside down to prevent the pooling of steam (which turns to water) inside of the packaging.

When deciding which items to put into each load, it is important to refer back to the surgical schedule for today and tomorrow. This will help plan and prioritise items needed sooner rather than later. If not done carefully, the OT may be delayed because they are waiting for instruments. If unsure, liaise with the OT nurses at the beginning of each day so a plan for 'rotation' can be put in place.

Starting the load

Once the chamber has been loaded, the sterilization cycle can commence. To do this:

- follow the instructions from the machine manufacturer
- close the door
- check the settings are correct (temperature and time)
- press start.

End of the load

Once the machine has finished it will release the pressure inside the chamber. Thereafter, the instruments can be removed. Depending on the sophistication of the sterilizer, it can be immediately opened or it will require a few minutes wait in order to let the steam out. Regardless of the technology, wear heat resistant gloves because the machine will be hot. Also be aware that with some machines the steam may come out quickly. Therefore, the SNT needs to position themselves away from the door so that the steam goes in the opposite direction. Then open the door slowly and leave it open about 5-10 cm for a minute – to allow the steam to be expelled before completely open the door.

Once the steam has been expelled and the door is opened, instruments can be removed and placed on the cooling racks. Here are some tips to assist with this process:

- wear heat protective gloves
- use any provided tray-grasping tongues to avoid having to touch the metal
- remain mindful that the chamber sides will be very hot and may cause burns
- place instruments onto a cooling rack before placing them in the storage area
- ensure all instrument indicator tape/labels have changed colour. If they have not, then this could indicate that there is an issue with the sterilizer. Follow up accordingly and re-sterilize the instrument.

Note: this safety and checking process is routine for all types of sterilizers.

Care and Management Once Sterilized

Shelf life of sterile items

The shelf life varies depending on the type of packing material and the conditions the items are kept in (see Table 7.3). In general:

- All paper/kimguard and peel-pouch items are considered sterile forever, assuming they are kept in a good environment.
- Metal drums with vent holes routinely found in lower resource locations do have a shelf life of about 24-48 hours. Always check the policy on what works best for the facility.
- Material wrap also has a shelf life.

Linen package	4 weeks
Linen package wrapped in a plastic bag	8 weeks
Metal drum	4 weeks
Metal drum wrapped in a plastic bag	8 weeks
Paper/kimguard	Forever, if stored correctly

Table 7.3. Shelf life

Note: In some lower resource locations newer style metal and plastic instrument trays have been introduced. These do not expire in the same short time frame as traditional drums because they have a filtered vent system (via a filter-paper) which helps to preserve their state. Always check to see which system is available at the facility.

A good environment for instruments means:

- stored in a temperature controlled area to the same standards (air control)
- placed, at the least, 15-25 cm off the ground
- placed, at the least, 15-20 cm away from the ceiling or ceiling vents
- preferably stored on metal racks – because the racks can help ventilation and can be easily cleaned
- preferably, if air control is a problem, place in a closed cupboard or under a dust-proof protective cover
- stored above waist height.

Packaging (i.e.paper or material) are not considered sterile any longer if:

- they are wet or moist
- have a hole in their packaging.

Note: never touch wrap, peel material or paper with wet hands or if moisturising cream was recently applied to hands. The moisture cream can place a greasy film over the material and potentially make the material porous. Therefore, do not apply cream during work – apply only at home or after work.

Storage of sterile items

Correct storage of an item ensures that it remains sterile for its full shelf life. This depends upon:

- type of package
- use of dust covers: a plastic dust cover wrapped around a linen package extends its shelf life from 4 to 8 weeks
- storage conditions: open versus closed shelves
- a closed shelf does not extend the shelf life of an item but it does protect it from dirt, dampness and constant handling
- number of times a package is handled
- conditions of the storage area: cleanliness, humidity, temperature.

Stock rotation

Items must be rotated to prevent wastage through expiration. Place older stock at the front, and new stock at the back of the shelf or cupboard (or new to the left and old to the right, or vice versa). Use the old (in date) stock first. This means items are less likely to expire.

Tracking and Log Book Systems

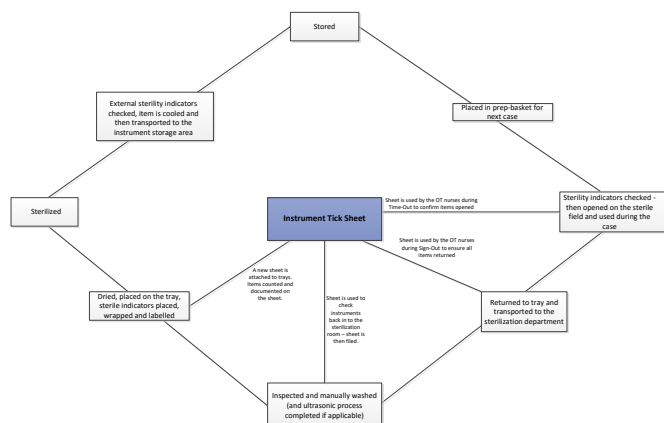

Diagram 7.1. Continual Reusable Instrument Cycle.
Source: Machin, 2014.

The sterilization department is responsible for tracking instruments and equipment at all points in their use cycle (Diagram 7.1). They need to know if instruments are ‘in use’, in the cleaning phase, removed from service or sent to be repaired. They also need to know how instruments are being sterilized, the levels of stock, and if new instruments are required. They do this through a tracking and logging system. Depending on the size of the facility this can be an electronic system or it can be a paper-based documentation system. For the purpose of this manual, this section will discuss the paper-based system.

Tray uniformity and sign-off

All trays are accompanied with a check sheet which the sterilization nurse completes. It states which instruments are on the tray. The sheet is then folded and taped to the top of the tray and sterilized together.

In the OT, the scrub and circulating nurse then tick off at the beginning and end of the procedure, which items they have received and those they are returning at the end (i.e. confirmation that they did not lose anything). The tray and paperwork is then returned to the sterilization room. In some instances, the patient’s name can be written on the form.

Once the instruments are in the dirty area, the SNT signs to say all instruments have been returned. The sheet of paper can then be placed into the patient’s chart as part of their medical records. This can be used to demonstrate that all instruments were accounted for and that those involved confirm the instruments were sterilized. Please see Appendix B for an example of an instrument check sheet.

Documentation: load counts, load controls

Sometimes, it is difficult to remember which items are currently inside the sterilizer. Therefore, a load document should be completed. This allows the SNT to itemise what is in each load. This can help:

- Inform the OT staff of how much longer an item will be until it is ready.
- Help determine costs for sterilization by calculating load capacity.
- Outline commonly used items. This might assist in future purchasing needs.
- Identify if there has been an overloading of chambers or documenting issues with sterilization.

Log book

Log books can be maintained for a variety of needs but primarily:

- Maintenance – listing which instruments have been sent for repair. They are then signed back in when returned.
- De-commission – lists instruments that have broken and been removed from service. This helps management understand life-spans of instruments and assists them with purchasing decisions in the future. It also helps to inform others that items are no longer available.

Low cost tracking solutions

Sometimes tracking instrument trays can be complicated and knowing which instrument belongs to which set can be confusing. Therefore, there are several methods that can be implemented, such as:

- Engraving instruments with a tray number.
- Using a special coloured surgical tape, mark all instruments from one set with the same colour tape.
- e-Tag tracking stickers which use a barcode system to identify instruments and their location. This is a high resource system.

These methods can also help alleviate issues with new or junior staff who may not know the names of the instruments. They can also be used to speed up the turnaround of the service as the staff need only know the number or colour of the instrument, and to count that they have the correct amount. It also helps to quickly identify if something is missing.

Sterilization Methods

Sterilization

Sterilization is the complete destruction of all pathogenic micro-organisms, i.e. bacteria, viruses, fungi and spores. There are no half-way measures—an item is either sterile or it is not.

Sterilization is achieved only by:

- Steam under pressure.
- Dry heat.
- Gas.
- Vapour.
- Ionising irradiation.

Advice on autoclaving

Water

- Use only distilled or filtered rain water in an autoclave, i.e. purified water only. Do not use tap water or mineral water.

Timing

Sterilization time depends upon the pressure materials of the item and packaging. Table 7.4 provides a guide.

Articles	Steam pressure	temp	temp
	lb/in2	°C	min
Drapes, linen, and gowns:	30	134	45
Instruments:	25	124	30
Rubber articles:	10	116	40

Table 7.4. Autoclave settings

Free standing autoclaves have a pressure control valve which allows for the above adjustments to be made.

Portable autoclave

Suitable for

- outreach clinics
- metal instruments and sharps
- drying theatre drapes, and gauze.

Power source

- gas or kerosene, but also electricity.

Timing (Table 7.5)

Steam Pressure	Temp	Time
Lb/in2	°C	min
5	116	40
10	121	20

Table 7.5. Portable autoclave settings

Advantages

- efficient
- low cost
- easily maintained.

Limitations

- fairly small - therefore load size is limited.

Below are some alternative methods that may be available in the facility.

Dry heat/hot air oven

Destroys

- all micro-organisms.

Suitable for

- metal instruments, some types of toughened glass and plastics
- very good for ophthalmic instruments as it dries them thoroughly, and can be used as a drying cabinet after the operating list has finished.

Power source

- electricity (1 kW, single phase). Too small a generator does not give enough power to keep a hot air oven running over a power failure.

Timing

- 180 °C for 120 minutes.

Limitations

- long sterilizing cycle - so not suitable for a busy OT complex
- maintenance and sterilizing time can restrict a long operating list
- instruments are too hot to handle when the cycle is completed, and must be left to cool
- often the cabinets are small and do not take many sets of instruments
- must be placed in well ventilated area for air to circulate through the oven

Staff are often unaware of how to use the machine and continually open the door. If this occurs then the chamber cannot maintain the heat level and so, in principle, the instruments are not exposed to the correct temperature. Therefore, ensure all staff are familiar with how to use this machine.

Gas

Ethylene oxide (C₂H₄O)

Destroys

- all micro-organisms.

Suitable for

- all instruments and materials, especially those that do not tolerate heating or soaking, e.g. eye shields or tubing.

Timing

- 12 hours

Limitations

- it is expensive to set up and run
- limited to large tertiary centres with specialty trained staff
- requires complex gas removal and environmental monitoring systems.

WARNING: gas is extremely hazardous as it is potentially explosive. For this reason, hospitals are phasing out this technology. If currently using this method, have a meeting to discuss how it can be changed to a safer method.

Ionising irradiation

This method of sterilization is used commercially by large manufacturing companies, especially for syringes, needles and suture material. It is very expensive and usually available only to large tertiary centres. Further details are beyond the remit of this manual.

Vapour

Formalin

A cabinet containing formalin tablets can be used to sterilize instruments and also to store them. Such a cabinet may be made, for example, from an old refrigerator, provided it is airtight and can be fitted with a heat source. Alternatively, it can be made from a suitably sized and airtight tin.

Destroys

- all micro-organisms.

Suitable for

- metal instruments, toughened plastic, glass and delicate tubing.

Power source

- electricity, if cabinet is large enough to require a heat source to force circulation of the formalin vapour. Perforated metal shelves assist the vapour to circulate. The heat can be provided by a 25 W light bulb mounted low down in the cabinet.

Timing

- sterilizing time is 12 hours, during which time the cabinet must not be opened.

Limitations

- the area around the formalin cabinet should be well ventilated
- formalin is an irritant to eyes and skin, and precautions must be taken in handling. It is a known carcinogenic.

Cautions

- PPE must be worn
- Cheattle's forceps must be used to remove instruments from the tin or cabinet
- although this method is practised widely in rural areas, its effectiveness is said to be uncertain. Therefore, the use of formalin is not encouraged if alternative methods are available
- safe practice points, to ensure quality control when using formalin:
 - instruments must be dismantled, where possible
 - sterilization must be done in a sealed, airtight container
 - requires 7g formalin per cubic metre
 - tin or cabinet must be left unopened for 12 hours and marked with the time and date it was sealed
 - instruments must be rinsed in sterile water before use
 - container is secure and will not tip or become a spill hazard.

Other Methods

This section will expand on disinfection methods other than steam-autoclave sterilization. While steam-autoclave is the preferred method, knowledge of other methods may be useful for smaller, remote or mobile facilities that do not have access to the larger sophisticated sterilization department set-ups. By reviewing the principles below, SNT and OT teams will be able to find better ways to manage instrument care based on what is available.

Boiling

Boiling achieves high level disinfection.

Destroys

- bacteria and viruses. It takes 4 hours to destroy spores by boiling; in most situations this is not practical.

Suitable for

- most types of metal, toughened glass and plastics

Power source

- electricity, gas, kerosene or charcoal.

Timing

- 10 minutes in boiling water destroys bacteria and viruses. If instruments are added to the water during the 10 minutes, then the timing must start again.

Limitations

- at high altitude water boils at a lower temperature. (About 10°C lower for every 300 m above sea level.) The higher the altitude, the longer the instruments must be boiled
- quickly blunts scissors, knives, etc.
- instruments must be totally immersed in the water
- use only distilled or rain water to prevent mineral deposits settling on the instruments and damaging them.

Usage

- do not drop instruments into a boiler
- place them gently using a Cheattle's forceps. If possible, place instruments first into a perforated metal box, with a silicone mat or a piece of gauze in the bottom so that they do not move against the metal
- clean and refill the boiler at the end of each OT session
- never leave instruments to soak in water overnight as they will rust and corrode. They will also rust if they are not dried well
- boilers should be descaled monthly with sodium bicarbonate tablets. Leave the tablets with enough water to cover the element overnight, and then rinse the boiler thoroughly next day
- instruments may get a whitish deposit on them from frequent boiling in areas where there is a high salt deposit in the water. (This will not happen if distilled or rain water is used.) To prevent this from building up on the instruments, a very weak solution of acetic acid (vinegar) can be used when cleaning the instruments (1 tbsp. to 2 litres of water). Soak for no longer than one hour.

Steaming (non-autoclave)

The steaming method is a popular but unreliable method of disinfection. The author does not recommend its use, but is aware that many people insist on using it. For that reason only, the following details are provided:

Destroys

- bacteria and viruses.

Suitable for

- metal instruments, including sharps. Note: there is serious concern, however, about whether the steam reaches the lumens of instruments. Steaming is sometimes chosen only in an attempt to avoid blunting of instruments. There is no other direct benefit of this method.

Limitations

- spores are not destroyed
- at high altitude water boils at a lower temperature. (About

10°C lower for every 300 m above sea level). Steaming should not be used at altitude.

Usage

- ensure the water is at boiling point before placing the instruments in the steamer
- maintain the level and boiling point of the water
- place instruments in a rack above the level of the water
- steam the instruments for a minimum of 10 minutes, and preferably 35 minutes
- keep the receptacle covered with a lid.

Liquid chemicals

Soaking in chemicals should be used only when alternative methods are unavailable or are known to cause damage. Be aware that:

- Over a prolonged time, chemicals can cause staining of the instruments and deterioration of rubber.
- Instruments should not be left to soak for an extended period as this causes blunting and corrosion of the metal.
- Rust inhibitors, e.g. sodium nitrite 0.1%, can be used to prevent rusting.
- Manufacturers' instructions must be noted or a pharmacist's assistance sought.
- Ensure that surgeons are informed that this method is in use at the facility.
- Instruments must be rinsed in sterile water before being passed to the surgeon.
- It is not advisable to use chemical soaking for syringes, needles, other skin-cutting instruments and any instrument with a lumen.

Chlorhexidine

Chlorhexidine is readily available at low cost. Items must be completely immersed in a covered container, and thoroughly rinsed under a stream of sterile water before use.

Destroys

- bacteria, spores and fungi, but does not destroy viruses.

Suitable for

- plastic, rubber and metal instruments.

Timing

- 10 minutes.

Limitations

- evaporation: top up regularly if working in a hot climate
- can cause disintegration of rubber
- it has a tendency to blunt sharp instruments
- it is not advisable to soak sutures as the spirit infiltrates the suture material, and, even after rinsing, particles are still present which may cause corneal oedema post-operatively.

Glutaraldehyde

WARNING: Glutaraldehyde is widely used in lower resource locations where steam sterilization has been impractical and other methods have been unavailable. Today however, it is universally agreed that glutaraldehyde should be avoided as it is unsafe.

If the facility is using glutaraldehyde then discuss with the manager

about putting in place plans to change practice - either to a better decontaminant and enzymatic solution or to a lesser irritant product such as Perisafe which is available in some countries.

Povidone Iodine

Povidone Iodine 10% solutions is probably the most popular, widely available and versatile disinfecting agent available to lower resource locations. It has the advantages of being inexpensive, does not blunt sharp instruments, and has the least side effects of all the soaking solutions.

- caution is strongly emphasised in its preparation as varying strengths are recommended for different practices
- often available in a powder
- it is commercially available as Betadine.

Destroys

- bacteria, spores and fungi, and some viruses, but not entero- and adenoviruses.

Suitable for

- all metal instruments, sutures and blades, 10% solution disinfectant solution for soaking instruments.

Timing

- 10 minutes.

Other applications

- facial skin preparation 5-10% solution
- the night before surgery for general facial cleanliness
- the day of surgery prior to local anaesthetic injection
- at the time of surgery prior to draping
- hand scrub 5% solution using liquid soap
- eye drops 0.5% solution
- pre-operatively as an antiseptic, four times a day, before surgery
- following local anaesthetic injection, instilled into the conjunctival sac to reduce the risk of infection from the patient's own flora.

Limitations

- stains fabric, surfaces and instruments
- skin irritation has also been reported
- Hard to see instruments submerged in the solution due to the dark colour
- makes gloves sticky, which can affect the handling and passing of surgical instruments.

For sterilizing instruments, fully immerse for 10 minutes ensuring that parts and tubes are flushed through with the solution. Rinse off with hot, sterile water flushing well all the parts with a syringe.

Isopropyl alcohol 70% (methylated spirit)

Methylated spirit is readily available at low cost.

Destroys

- bacteria, spores, some viruses, but not entero- or adenoviruses or fungi.

Suitable for

- indirect ophthalmoscopy lenses and metal instruments, heat sensitive endoscopes, airways, endotracheal tubes and anaesthetic face masks. These must be completely immersed.

Timing

- 10 minutes.

Limitations

- highly flammable, requiring extreme caution in its handling
- evaporates quickly, so the container should be covered with a lid. The fluid level must be checked frequently and topped up during the day if necessary
- disintegrates plastic, e.g. artificial eyes and rubber, if left in contact for long periods.

For indirect ophthalmoscopy lenses (e.g. 20 dioptre), methylated spirit does not stain or cause grease smudges on the glass of the lens. It evaporates quickly and does not damage the cement that is used to fix the glass lens. Do not rinse, but allow the spirit to evaporate, then wipe gently with a drape or lens cleaning cloth. Note: do not use a gauze as this may scratch the glass.

Methylated spirit flame

WARNING: While methylated spirits have been included in this manual, it is a serious fire hazard (flammable) so avoid using it.

Metal hand washing bowls are sometimes too big to sterilize in the autoclave. They can be flamed with methylated spirit. Pour a small quantity of methylated spirit into the metal bowl, ensuring that it is sitting on a non-flammable surface or bowl stand. Ignite and wait for the flames to subside. The flames must be completely extinguished before adding any further solution.

A methylated spirit lamp can also be used to sterilize glass rods for cautery.

Hypochlorite

Destroys

- bacteria, spores and viruses.

Suitable for

- indirect ophthalmoscopy lenses applanation prism tips.

Timing

- 10 minutes.

Limitations

- highly volatile and corrosive.
- metal containers must not be used.
- it acts as a bleach.

Sodium hypochlorite 0.5% disinfectant

Requirements

- sodium hypochlorite 1% 500 ml
- boiled water (rainwater preferred) 1 litre.

Preparation/use

- add the Sodium hypochlorite to the water, making a total quantity of 1.5 l.

Shelf life

- seven days.

Note:

- items must be completely immersed in a covered container for a minimum of 10 min and rinsed under a stream of sterile water before use
- use a plastic or glass container only. Metal containers for shelf or soaking storage are not suitable, as sodium hypochlorite is a bleach, highly volatile and corrosive. It must not be used to disinfect a Schiötz tonometer
- the quantity used for soaking instruments must be changed daily.

Acetone

Acetone has been a popular antiseptic and disinfectant in many low resource locations. Current texts do not list it as a recommended chemical disinfectant. A literature search has shown conflicting opinions, and to include it in a manual designed to offer safe guidelines for clinical practice would be unhelpful. There are disadvantages to its use: i.e. it evaporates easily, it is highly flammable and it does not destroy fungi or spores.

Fizzy cola drinks

WARNING: The authors acknowledge that in some lower resource locations that fizzy cola drinks are used as a cleaning solution and are sometimes used to remove tarnishes and stains from metal equipment and instruments, prior to their full decontamination. While this process may make the instruments look clean, to the best of the author's knowledge, there is no available evidence on the safety of this solution to both the ophthalmic instrument and the ophthalmic patient. Therefore, seek alternative cleaning methods.

Domestic pressure cooker

Suitable for

- Metal instruments and sharps in outreach clinics.

Power source

- Wood, charcoal, gas, kerosene or electricity.

Timing (Table 7.6)

Steam Pressure	Temp	Time
Lb/in ²	°C	min
5	116	40
10	121	20

Table 7.6. Domestic Pressure Cooker settings

Advantages

- quick
- efficient
- low cost.

Limitations

- Fairly small - therefore load is limited to instruments
- No drying cycle, so instruments can corrode if left in container for several hours. Like autoclaves, pressure cookers can be dangerous if staff are not sure how to operate them.

Note: the pressure cooker will not reach the desired temperature if the lid is continually removed. Time the opening and closing to maximise the heat build-up.

WARNING: Be mindful that the pressure cookers may need to be placed on a hot plate or open flame. This may be a safety risk to staff (i.e. burns, fire and electric shock). Therefore, seek alternative methods before implementing this system.

References

1. Ahuja, S. What Is An Autoclave Sterilizer? 2011. Ezine@rticles. <http://ezinearticles.com/?What-Is-An-Autoclave-Sterilizer?&id=5974275>
2. Anderson, O, A, Lee, V, Keegan, D., & Validis, G. A model for the management of an atypical endophthalmitis outbreak. *Eye*. 2005;19, 972-980.
3. Armitage, W, J, Tullo, A, B., & Ironside, J, W. Risk of Creutzfeldt-Jakob disease transmission by ocular surgery and tissue transplantation. *Eye*. 2009; 23, 1926-1930. Center for Disease Control. Guideline for Disinfection and Sterilization in Healthcare Facilities. 2008. www.cdc.gov/hicpac/pdf/guidelines/Disinfection_Nov_2008.pdf Accessed 06.06.2016.
4. Charter, L. Cleaning equipment - Not all disinfectants have power to eliminate adenovirus type 8: Recent study shows only one-third of agents tested were effective germicides. *Ophthalmology Times*. December 2006; 1.
5. Dinakaran, S., & Kayarkar, W. Debris on processed ophthalmic instruments: a cause for concern. *Eye*. 2002; 16, 281-284.
6. Henning, C. Care and handling of ophthalmic microsurgical instruments. 2011. The American Society of Ophthalmic Registered Nurses. San Francisco.
7. Machin, H. Operating Theatre Manual. 2014. Fred Hollows Foundation NZ, Auckland.
8. Marsden, J. Toxic Anterior Segment Syndrome. *International Journal of Ophthalmic Practice*. 2012; 3, 3.
9. Parikh, C, Sippy, B, D, Martin, D, F., & Edehauser, F. Effects of enzymatic sterilization detergents on the corneal endothelium. *ARCH Ophthalmology*. 2002; Vol 120;165-172.
10. Root, C, W, Kaiser, N., & Antonucci, C. What how and why: Enzymatic instrument cleaning products in healthcare environments. *Healthcare Purchasing News*. November 2008.
11. Standards Australia and Standards New Zealand. ANZ4187 Standard: Cleaning, disinfecting and sterilizing reusable medical and surgical instruments and equipment, and maintenance of associated environments in health care facilities. 2003.
12. Tauras, R. Distilled water vs. saline soak; tears in wrapped sets; keeping instruments open for cleaning. *Healthcare Purchasing News*. December 2013.
13. 3M. Technical Information: 3M™ Comply™ 1233LF Bowie-Dick Test Pack. 2010. 3M. <http://multimedia.3m.com/mws/media/6300870/comply-1233lf-bowie-dick-test-pack-tech-information.pdf> Accessed 06.06.2016.

SECTION 8

Ophthalmic Surgical Instruments.

Contributor: Heather Machin



This section will explore the usage and handling of instruments. A suggested instrument list for common procedures has also been provided at the end of this section.

Introduction

All instruments should be used only for their specifically intended purpose and nothing else. They can be damaged by inappropriate use, e.g. a needle holder for 9/0 suture must not be used for a 4/0 suture.

Surgical instruments can be divided into two main categories:

1. sharps
2. blunts

These can be further categorised into those which are used as follows:

- outside the eye
 - extraocular or macro instruments for extraocular surgery, e.g. squint hooks for muscle manipulation.
- inside the eye
 - intraocular or micro instruments for intraocular surgery, e.g. extra- or intracapsular cataract surgery.

Instrument Types

Sharps

Sharps include:

- scissors
- scalpel blades
- diamond knives
- Graefe knives
- Beaver blades
- razor fragments
- trocars.

Scissors

Scissors are designed to slice and cut tissue. There are various sizes and shapes depending on their purpose, and the basic design has two cutting blades at the working end which are bevelled to produce a slicing action. Scissors are also used for blunt dissection when the surgeon needs to separate and divide the tissue to avoid bleeding or the rupturing of cysts.

Examples

Spring action

- Westcotts (conjunctival)
- De Weckers (iridectomy)
- Barraquers (corneoscleral)
- capsulotomy scissors

Manual opening

- iris
- enucleation.

The scissor tips can be

- blunt/heavy, e.g. Enucleation
- sharp/micro and delicate, e.g. Vannas

- curved/micro and delicate, e.g. Westcotts
- capsulotomy.

The scissors should be held with the blade points away from the surgeon so they can take the handle of the instrument from the scrub nurse.

The blades and joints must be thoroughly cleaned before being handed to the surgeon. If the surgeon comments that the scissors are blunt, they should be removed from the set immediately and sent for sharpening. A blunt or damaged pair of scissors can irretrievably damage a patient's eye. For example, a blunt Vanna's used for an iridectomy may cause the iris to bleed and damage the muscle. Spare sterile scissors must always be available.

Micro-scissor and intraocular scissor points are extremely delicate and should be passed in a manner that allow the surgeon to take the handle without touching the tips. All micro-scissors have a spring action and are kept permanently open until pressed closed by the surgeon.

Corneal scissors often come in pairs. There are right corneal scissors and left corneal scissors, which are distinguishable by the tips, as they point in different directions.

Flat or angled scissors (instead of curved) are also available, and these are known as Universal (or Barraquer) Corneal Scissors. They can be used to cut to both the right and the left.

Westcott scissors are curved and can be used to cut the conjunctiva and corneal sutures.

All scissors, when not in use, need to have their tips covered by protectors which must be long enough to cover the scissor blades, without getting stuck.

Knives and scalpel blades

Knives and scalpel blades are used to incise and cut tissue. Blades cause bleeding as there is no crushing action.

A diamond knife is a very expensive instrument. If handled carefully, it can be used for thousands of operations. The diamond knife should always be retracted (not visible) when it is being passed.

Scalpel blades come in a wide variety of sizes and shapes. They all have specific tasks. N°15 blades and Troutman Razor fragments are used throughout ophthalmic intraocular operations. They must be sharp in order to give a clean incision.

The blade itself must not be touched. It is passed to the surgeon using the handle and with the cutting edge pointing downwards so that it cannot cause injury.

When a blade is being removed from a Bard Parker handle, it should also be held facing downwards so that if the blade breaks off, it will not cause injury. An artery clamp must always be used to mount and dismount a blade. (Specifically designed blade removers are also available in some countries.)

Razor fragments and Troutman blade handles are good to use in trabeculectomy surgery for raising the flap, cutting the partial thickness incision, making the grooved internal incision and cutting the suture on the knot.

The Troutman blade handle houses a small stainless steel razor

fragment, though an ordinary steel razor blade can be used. This must be steel because newer, non-steel blades do not fragment, and are therefore not suitable. A small portion of the edge of the blade is broken off by using a heavy needle holder and applying contraction. This gives a very sharp tipped blade and is inexpensive. The fragment is used once, but at least six fragments can be obtained from one blade.

Remember!

- always handle sharps safely
- use sharp dishes/protectors to rest the instruments on during the procedure
- never over fill sharp bins.

Blunts

Blunts include:

- artery (Haemostat) forceps
- drape forceps (towel clips)
- iris spatula
- cautery ball
- squint hook
- vectis loop
- needle holder
- dissecting forceps: toothed and non-toothed, grooved (notched)
- superior rectus forceps
- speculum
- cannula
- retractors.

Artery forceps

Artery forceps are used to clamp bleeding vessels or to hold a traction suture. Its jaws are serrated to ensure a grip that will hold the tissue or suture firmly but without cutting the suture. An artery forceps may be curved or straight. Delicate artery forceps used in ophthalmic practice are called Mosquito forceps. Clips may also be used to hold suture or delicate tissue. These have serrated jaws but no ratchet.

Artery and Mosquito forceps work with a ratchet which allows the opening and closing of the jaws. If the ratchet is not working properly the forceps will not hold effectively. The forceps can be tested by holding it up to the light in the closed position on the first notch. If light shows through the jaws, it will not grip firmly. The jaws of the forceps should be in alignment.

An artery forceps should be passed to the surgeon in the same manner as scissors.

Needle holders

Needle holders are for use for holding the needles of sutures. The size of the suture determines the size of the needle holder. Needle holders are classified as either intraocular or extraocular:

- Intraocular needle holders hold 10/0 - 8/0 sutures - they have a smooth surface which allows the surgeon to manipulate the needle to the required angle during suturing.
- Extraocular needle holders hold 7/0 - 4/0 sutures - their jaws have a fine crisscross pattern on the inside which ensures a tight grip on the needle.

All needle holders are used for gripping the suture thread once it has passed through the tissue. Because of this, it is important that the tips of the needle holder meet, otherwise the suture is not held firmly, and will slip out of the jaws of the needle holder.

Some needle holders work on a ratchet system, whilst most of the intraocular needle holders have a spring action (e.g. Castroviejo and Barraquer) or a locking device which is released by the surgeon once the needle is in place. Intraocular needle holders are either curved or straight to give precise positioning.

Dissecting forceps

- toothed forceps
- non-toothed forceps
- tying forceps: These are used for suturing. Available in two types:
 - non-toothed forceps with tying blocks
 - grooved forceps with tying blocks.

Every dissecting forceps, whether intra- or extraocular, has a very delicate tip. Protector sleeves – usually made of rubber, silicone or plastic tubing, need be applied prior to sterilization to prevent damage.

Needles and cannula(e)

All ophthalmic instrument sets contain a wide variety of needles and cannulas which are used for different purposes. Of note:

- cannulas are usually blunt
- needles are usually sharp

Cannulas - Before use of cannulas, ensure patency and remove air before passing to the surgeon.

At the end of each operation, the cannula must be flushed through to ensure continued patency. This is particularly relevant to a Simcoe cannula. Please see section 7 regarding cleaning techniques.

Needles - A specific sharps container, silicone mat or a piece of double thickness material is ideal to ensure the needles are protected and ready for use – and to prevent harm to the surgeon and scrub nurse.

Many of the cannulas and needles used in ophthalmic surgery are designed to be disposable but it is important to check the manufacturer's recommendations first.

Non-disposable retrobulbar needles

Non-disposable retrobulbar needles should be checked for burring at the tip, after each session. A burred needle can cause retrobulbar haemorrhage, and tears the tissues when it is withdrawn. If used, it is very painful to the patient.

Key points:

- never re-sterilise disposable needles
- always comply with sharp handling, waste management policy and report incidents and injuries immediately.

Multi-part items

Some items have multi-parts, i.e. a microscope viewing system and Charles Flute Cannula – both used in retinal surgery. The parts need to be separated during all stages of the sterilization cycle. They are only connected and disconnected by the scrub nurse.

- If unsure, check the manufacturer's recommendations.

- **Bone cutters** – ensure that bone is removed from inside any cutters or nibblers prior to sterilizing.

Ophthalmic Surgical Instruments

Figure 8.1 Examples of dissecting forceps

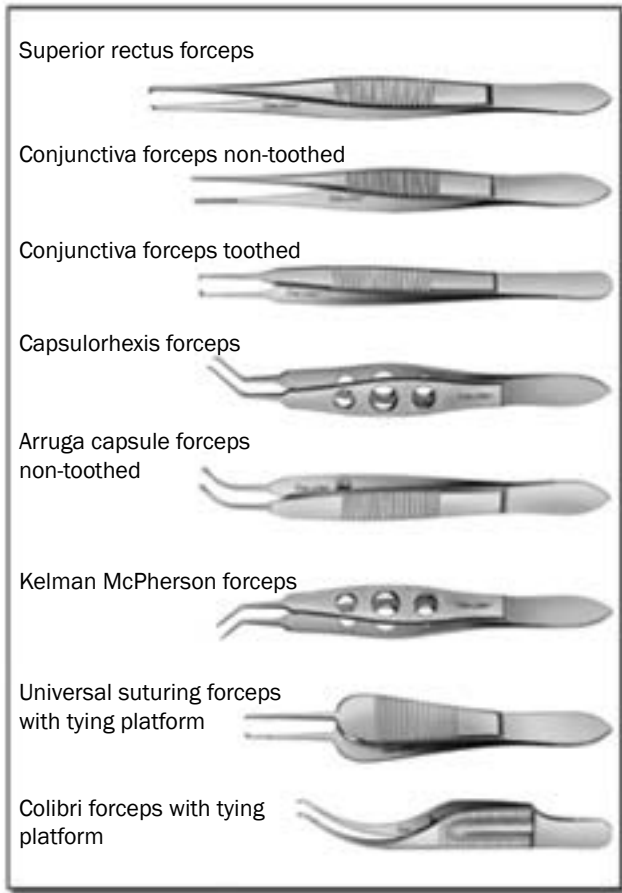

Figure 8.3 Types of forceps tips

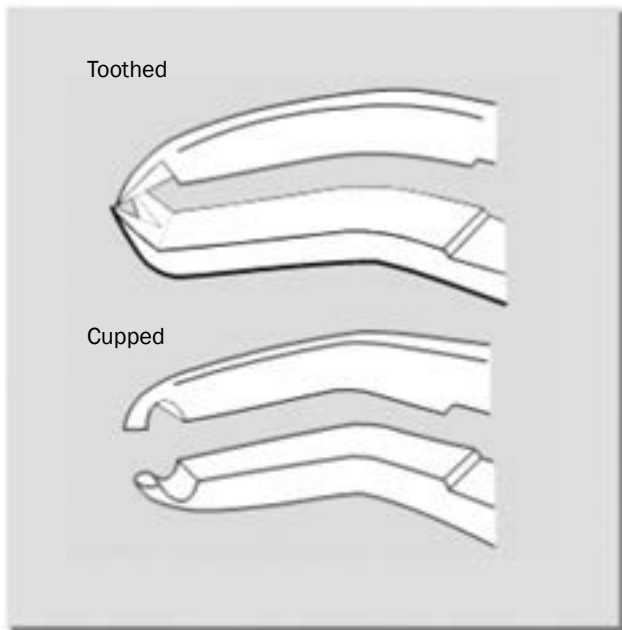

Figure 8.2 Examples of artery and holding forceps

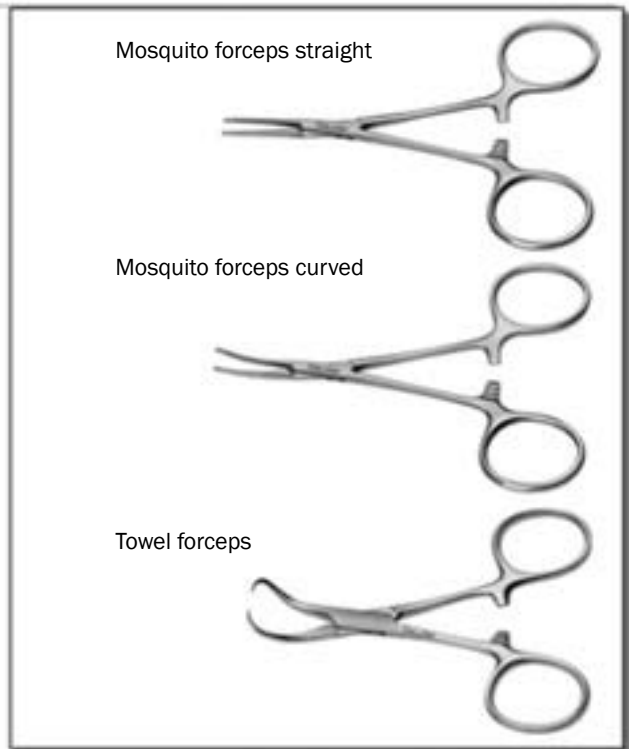
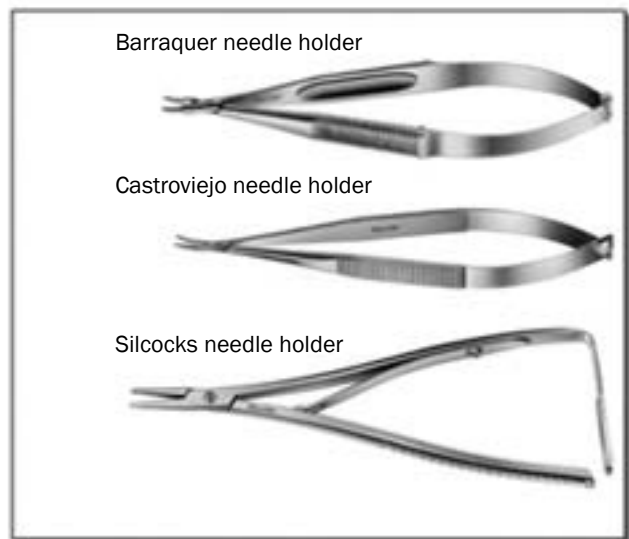

Figure 8.4 Examples of needle holders



Note:

Terms used to identify instruments vary among eye units and their suppliers.

Figure 8.5 Examples of scissors

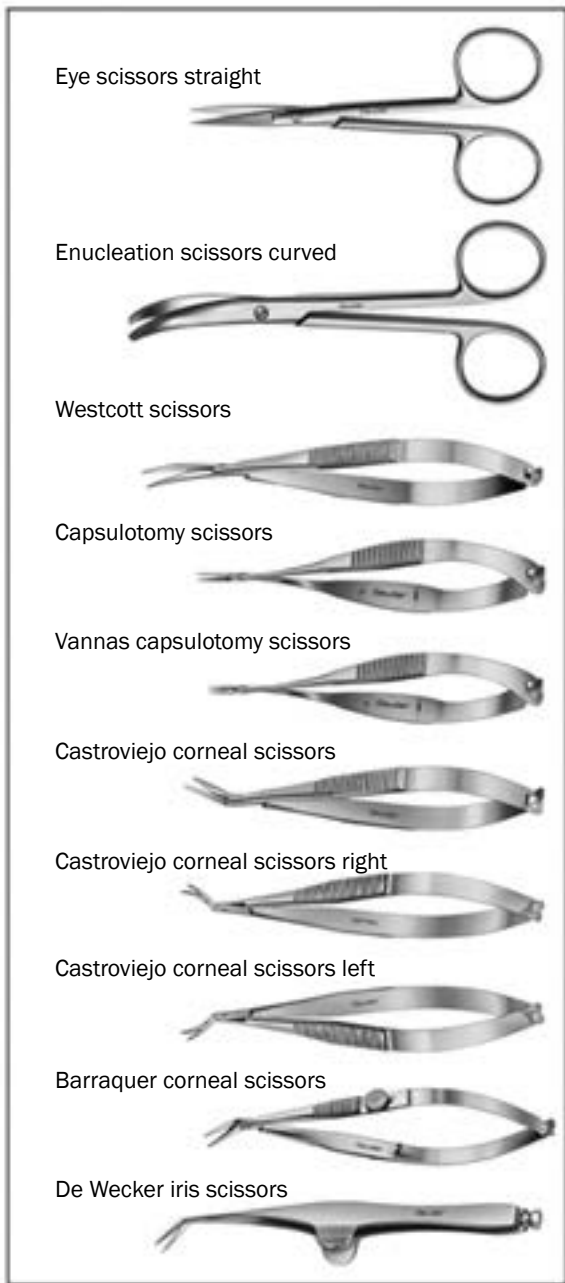

Note:

Terms used to identify instruments vary among eye units and their suppliers.

Figure 8.6 Examples of knives

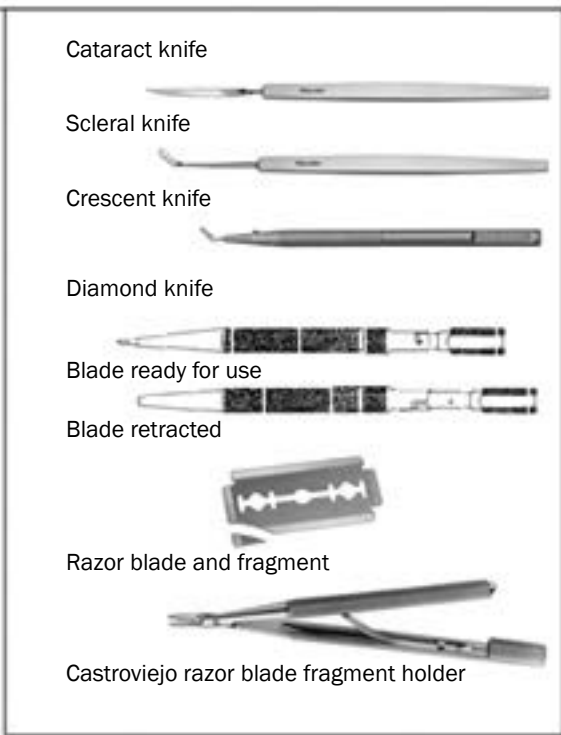

Photo 8.1 Passing scissors (but gloves must be worn)

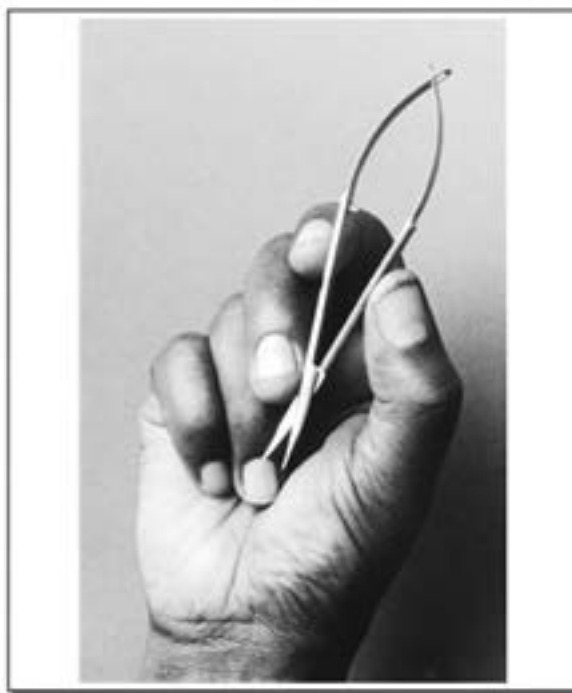

Figure 8.7 Examples of cannulae

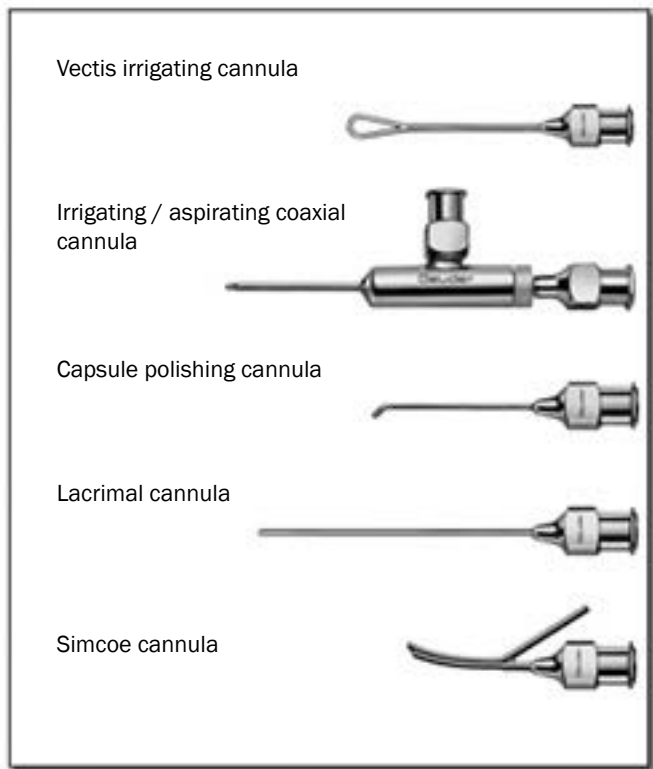

Figure 8.8 Examples of eye specula

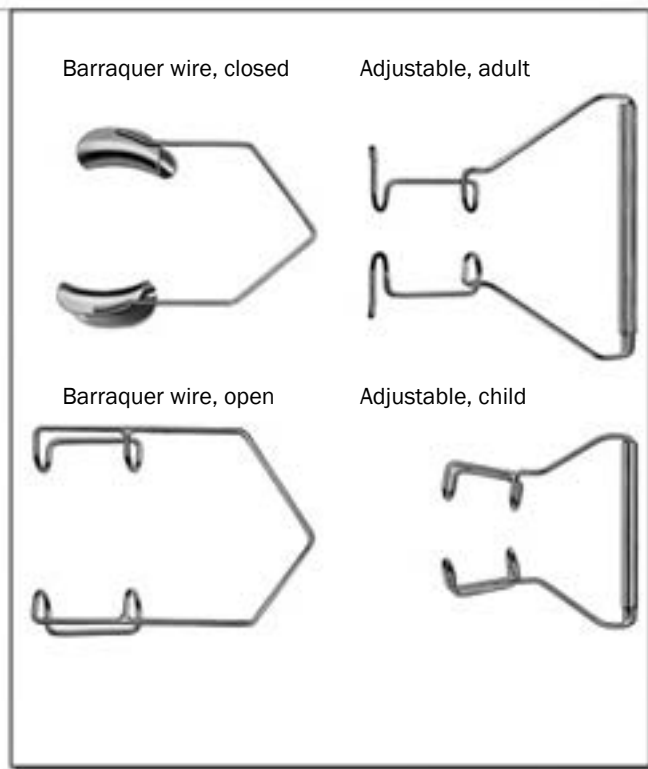
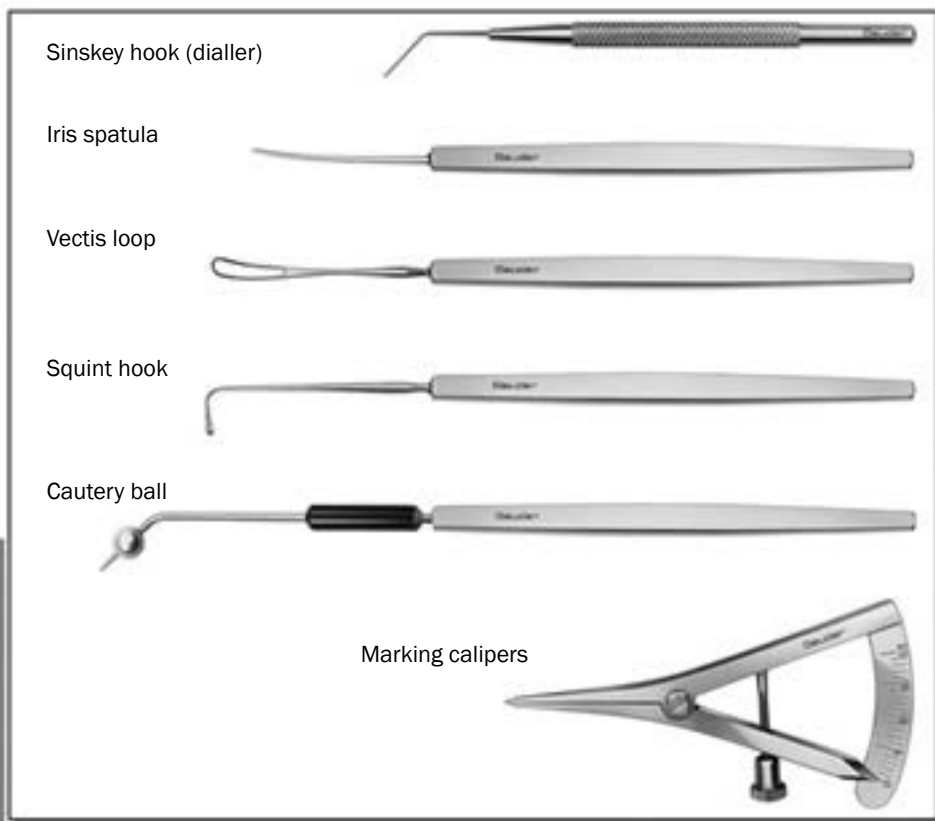

Figure 8.9 Examples of other common instruments



Note:

Terms used to identify instruments vary among eye units and their suppliers.

Marking calipers



Examining the Integrity – and Packaging for Reuse

Before instruments and equipment are used or re-processed, special care must be given to ensure they are in full working order. Routine checks by the scrub nurse when opening - and again by the sterilization nurse prior to packaging for sterilization - must continually take place to ensure defected instruments are not handed to the surgeon – and worse, used on a patient. This section outlines key integrity checks.

Physical Examination

Integrity

Examine the items surface. Remove any item that is broken – if unsure, ask the surgeon to examine and advise. Tips need to be joining, hinges bouncing, sharp surfaces intact.

Staining

- **Brown/orange** – often mistaken for rust. Check to determine pitting and corrosion, and before eliminating the source of the colour as a blood stain. This can be rubbed off. If it is not removed, it may cause a chemical reaction and corrosion. If rusted, remove from service.
- **Light and dark spots** – caused by slow evaporation of condensation of the water used in sterilization.
- **Purplish-black spots** – ammonia. Thorough rinsing and drying should eliminate these.
- **Bluish-black spots** – due to electrolysis. They are hard to remove and are caused by metal ions from one instrument becoming attached to another when instruments of different metals are mixed in the cleaning stage. This needs special attention if using an ultrasonic machine.
- **Black** – due to acid. Can be rubbed off, but the underneath surface then remains rough, leading to further problems.

To minimise staining:

- Ensure good autoclave drying cycles. Any moisture in the packs will cause droplets and mark the instruments.
- Sodium nitrite can be used as an anti-rusting agent that can help prevent rust damage to instruments. Two tablets of Sodium nitrite dissolved in 500ml of water when washing the instruments will prevent rusting.
- Blood and saline are the worst causes of pitting and corrosion. Ensuring they are removed early is the best preventative strategy.
- Contact with Phenol, potassium permanganate, hydrochloric acid and Iodine should also be avoided.
- Instruments not rinsed thoroughly after sterilization with chemicals (e.g. Glutaraldehyde, and spirit solutions) will stain.
- Do not soak instruments for longer than one hour in any fluid.

Lubrication and Oiling

With repeated sterilization, instruments become stiff and difficult to open. A good quality lubricant can be used routinely (i.e. weekly) on hinged instruments. This is especially relevant when working in a very hot, dry climate. Please see section 7 for more detail.

Repairs

- Eventually scissors will need sharpening and forceps will need to be re-aligned
- There are instrument companies that can repair and re-sharpen instruments to a high standard.
- The OT should keep spare instruments to replace those sent

for repair. The cost of a good repair is still much cheaper than buying a new instrument.

- An instrument repair log will help track the location and status of an instrument.

Standard Instrument Sets

These are suggested lists only. Consult the surgeon and develop individualised Surgeon Preference Cards (templates available in Appendix B).

Intracapsular Cataract Extraction (ICCE) set

- wire speculum, Barraquer
- squint hook, Graefe
- cautery ball, Wordsworth, electric cautery or glass rods
- blade handle N° 3 Bard Parker, N° 15 blade vectis loop, Snellen
- iris repositor, Nettleship
- forceps: Landolts, superior rectus, Hoskins, grooved with tying platform forceps, Moorfields, toothed, Moorfields, non-toothed, cilia, suture tying, Arruga, non-toothed, Mosquito, curved and straight, Westcotts, conjunctival, universal, corneal, Barraquer, angled on flat, right and left cutting, De Wecker, iridectomy, Vannas or iridectomy
- needle holder, i.e. Silcock, Castroviejo, towel clip, cross action
- cannula, i.e. Rycroft 30 gauge, Southampton or Lang.
- syringes, i.e. 2 ml, 5 ml, 10 ml
- sutures - superior rectus, 5/0 cutting silk, 9/0 spatulated nylon
- other: needles, swabs, dressing and injection drugs.
- +/- cryoprobe.

Additional items (standby)

For ICCE with AC IOL implantation, add: Cannula, Simcoe - with silicone tubing, lens introducing, non-toothed forceps.

Extracapsular Cataract Extraction (ECCE) and Small Incision Cataract Surgery (SICS) Set

- wire speculum, Barraquer
- squint hook, Graefe
- cautery ball, Wordsworth, electrical cautery, or glass rods
- blade handle N° 3, Bard Parker and N° 15 blade
- blade handle, i.e. Troutman and Razor fragment, or blade, slit knife, disposable blade, keratome
- vectis Loop, Snellen
- iris repositor, Nettleship
- forceps, Landolts, superior rectus, Hoskins, grooved, with tying platform or forceps, Calibri, grooved, with tying platform, Moorfields, toothed, Moorfields, non-toothed, cilia, suture tying, Birks, suture tying, Mosquito, curved and straight, Utrata, capsulorhexis.
- scissors, i.e. Westcott, conjunctival, Barraquer's, angled on flat, De Wecker, iridectomy, Vannas, capsulotomy
- needle holder, i.e. Silcock, Castroviejo, towel clip, cross action
- cannula, i.e. Rycroft 30 gauge, anterior chamber, 23 gauges
- simcoe, irrigating and aspirating, with silicone tubing.
- syringes, i.e. 2 ml, 5 ml, 10 ml
- sutures - superior rectus, 5/0 cutting silk, 9/0 spatulated nylon
- irrigating solution: Ringer's Lactate, or Balanced Salt Solution
- other: needles, swabs, dressing and injection drugs.

Additional items (standby)

For ECCE with PC IOL implantation, add: lens introducing, non-toothed forceps, callipers, measuring hook, Sinsky dialler cannula, posterior capsule polisher viscoelastic gel.

Phacoemulsification set

For Phacoemulsification, adapt an ECCE/SICS tray with the addition of:

- guarded speculum
- capsulorhexis forceps
- phacoemulsification machine
- phaco hand piece, tip and accessory pack speculum
- keratome and/or diamond knife
- cystotome 27G
- y-nucleus rotator or iris retractor
- lens manipulator
- chopper
- spatula
- fine iris forceps
- bi-manual/irrigation and aspiration system
- IOL folding forceps or insertion injectors.

Trabeculectomy set

- wire speculum, Barraquer
- squint hook, Graefe
- cautery ball, Wordsworth, electric cautery
- blade handle N° 3, Bard Parker and N°15 blade Troutman and razor fragment or blade, slit knife, disposable, Tookes
- vectis loop, Snellen
- Kelly's Punch
- iris reposer, Nettleship
- forceps, i.e. Landolts, superior rectus, Hoskins, grooved with tying platform or forceps, Calibri with tying platform, Moorfields, toothed, Moorfields, non-toothed, cilia, suture tying, Mosquito, curved and straight, Westcott, conjunctival
- scissors, i.e. De Wecker, iridectomy, Vannas, iridectomy, micro Westcott, iris, sharp pointed
- needle holders, Silcock, Castroviejo, towel clip, cross action
- cannula, Rycroft 30 gauge, anterior chamber, 23 gauge
- syringes, i.e. 2 ml, 5 ml, 10 ml
- sutures, i.e. superior rectus, 5/0 cutting silk, 9/0 spatulated nylon, 7/0 spatulated vicryl (optional)
- other: needles, swabs, dressing and injection drugs
- +/- cytotoxics.

Tarsal plate rotation or lid surgery set

- Please see section 2.

SECTION 9

Management.

Contributors: Elise Chick, Emma Griggs, Phillip Hoare, Heather Machin, Noela Prasad and Lo Vola



This Section will discuss Management of the OT, Human Resources (HR), Policies and Documentation, Quality Management, Occupational Health and Safety, Education, Stock Management, and Health Information and data capturing.

Management

Management in the OT, as all other areas of healthcare, is important for ensuring care is safe, effective, equitable and economically viable. It also ensures that staff provide uniformed and professional care.

Management is not always easy and the ability to manage is, itself, a skill which involves knowledge of the task at hand, the practice within the sector, skills for managing people and the law and standards. The success of management depends not only on the manager, but on the environment and culture of the organisation and the professionalism, self-ownership and responsibility of the staff for whom they manage. This is because, management is just one part of the broader picture. Managers can only function effectively if provided with the autonomy to do so. They need to be empowered and supported in their decision-making, by both their supervisors and reporting staff.

Responsibility of the employee

Before examining various aspects of management, it is important to be aware of the actions of staff members, and the importance of their role in supporting the manager, by working together to improve the work conditions. To do this, here are some key tips:

- Support, advocate and empower the manager.
- Try new ideas – and share ideas.
- Help solve problems.
- Offer to help the manager and colleagues.
- Volunteer for added duties even if they are not a routine aspect of the job;
 - this will help to learn more, provide a challenge and support the organisation.
- Do not gossip about each other or spread false stories – this will ultimately undermine ourselves and the profession;
 - do not believe gossip said about each other.
- Only seek to consult the manager's superior, HR, the CEO or the Board, if there are system issues – rather than complaining specifically about the individual manager or minor issues. Seeking to complain about the manager, or replacing the manager, will not always fix managerial issues when problems are intrinsically ingrained in the organisation's fabric and culture. Sadly, it is difficult to detect this and often middle-management is blamed for system failures. Therefore, think critically and kindly about managers and the difficulties they too are challenged by.

It is important to remember:

- Managers are people too.
- They often need to retain base-staff skills alongside learning new skills such as budgeting, HR and education (depending on their position).
- Their workload can be much more than a base staff members. So, for example, if a member of the team is sick, on annual leave or if assistance is needed in the OT, then management will often assist. While this is helpful for the jobs that need doing immediately, this results in management not having the time to complete their non-clinical duties. Thus, their jobs accumulate – which in turn, means they are not able to resolve many of the issues the team are experiencing or are concerned about. Therefore, give them the space and time they need to do their managerial jobs.

- They care greatly about patient and staff needs, and will often place these above their own commitments. They will give up their lunch break, work after hours and take work home on the weekend (often without pay) so that they can improve working conditions for all. Therefore, offer to help them and support them as much as possible. The manager will be most grateful.
- They often cannot disclose details due to confidentiality.
- They often defend their staff even if the staff are not aware of this.
- They are required to ensure standards are maintained – even though this may not be popular. Sometimes, they are seen as the enemy or a difficult person but this is generally not the case. It is each individual staff member's responsibility to ensure that they recognise that the manager is legally obligated to maintain standards and it is reasonable for them to expect that staff do their part in maintaining services. It is also a good idea to support the manager to implement and maintain standards, and remember that they are doing their best within the working environment.

Types of management

Management does not just apply to someone with an official title. It can also refer to a staff member who has been given a special task to complete. In this instance they are “managing” a project and therefore, many management principles apply to them too. For example, a staff nurse who is the infection control nurse, or someone in charge of checking the gas-banks every day, is managing these tasks. These are all jobs/tasks which require an element of self-discipline, issue evaluation, risk mitigation and service maintenance.

Types of Managers

There are several types of managers and these roles evolve based on the personality of the individual and the cultural fabric of the organisation. Some managers/organisations over-manage while others under-manage. The term “micromanagement” can often be associated with individuals and organisations that feel the need to control and interfere with every aspect of a manager and staff member's duties and decision-making. Once this culture is in place, it is very difficult to remove. While those who use this technique may feel they are doing their job, sadly, micromanagement destroys cultures and prevents the team from taking self-responsibility, being empowered and progressing.

Management professionals do not recommend a micromanagement culture. Instead, they advocate that professionals, who are skilled in their job, be hired, and allowed to manage their job without unwarranted interference. In this system employees excel, ideas flow, and the system advances. To do this however, a strong progressive culture needs to be in place from the top/down and staff need to feel responsible and accountable for their own actions. The organisation needs to have good up to date policy, and to support all professionals equally. There should be equal representation and voice at all levels, (including allowing professionals to make decisions - within the standards and policies of their own area). There should be team meetings and reporting in this process, but the attitude and environment is positive and rewarding rather than negative and subjugating. It allows for the exchange of ideas and for new opportunities to ripen.

Human Resources (HR)

Human Resources (HR) refers to the support services provided by an organisation to ensure staff have what they need to perform their job and to ensure the organisation is adequately staffed. Usually, in larger organisations, specific HR specialist departments are established to provide this, however, in smaller facilities this is often allocated to senior team members or the Director of Nursing.

HR has several core functions, but includes:

- Caring for and supporting staff, who in turn, care for the organisation and the patient:
 - The theory being, that by nurturing staff, they will enhance the quality and professionalism of the business.
- Helping the organisation achieve its core objectives and business competencies, as outlined by an executive/strategic plan:
 - HR employs mechanisms to support and develop human potential (and capital), and aims to strive towards reaching set targets.
 - HR representatives often sit within the executive level in order to ensure they can support the organisation through acquiring and retaining human talent.

Some key aspects of HR Management, either by a specific department or a Nurse Manager (or area Manager) are:

- development of HR Policies and systems in line with employment laws
- development of position descriptions and job advertisements
- interviewing and hiring staff
- completing pre-employment checks (mandatory aspect of governance for clinical workers):
 - resume (sometimes called curriculum vitae - CV)
 - references
 - qualifications
 - clinical licence
- managing new employee orientation/induction;
 - completion of personal details – including bank details
 - familiarisation tours of the facility
 - mandatory safety training: i.e. fire, and occupational health and safety
 - orientation planning – teaching how to use the systems, how to find/ask for help, how to complete timesheets and so forth
 - introductions to existing and other new hire staff
- setting up a continual professional development system in conjunction with the professionals in the organisation, i.e. nursing or medical;
 - the HR team does not have to personally conduct the teaching, but they can help professional groups to arrange for a professional teacher on their behalf, and keep records of attendance
- managing existing staff;
 - providing a warm and friendly environment for staff to feel comfortable
 - this is generally termed an “Open Door Policy”
 - nurturing and developing a positive equitable workplace
 - ensuring organisational structures (organograms) are appropriate (via consultation of all bodies);
 - where possible, ensuring staff have career advancement opportunities within the organisation
 - ensuring an ethical, practical and clinically appropriate organisational structure is in place to

- support all professional bodies
- recognising professional variances in reporting structures
- supporting area managers to complete annual appraisals
- support area managers with the completion of any mandatory training requirements, i.e. workplace safety or a specific skill sign-off
- providing avenues for staff to fairly share their voice
- supporting both managers and staff without bias or agenda
- providing staff with an opportunity to provide feedback or share their opinions (i.e. surveys);
 - note: the question design and the outcome analyses needs to be conducted by someone experienced and knowledgeable about the sector and/or professional body. This will ensure results are interpreted within context. Surveys can be anonymous.
- Managing end of contract staff;
 - providing end of contract letter
 - arranging a ‘hand-over’ opportunity between the exiting employee and the person taking on the role. This will allow for continuity of service
 - providing a reference if asked by the employee
- ending employment via termination or redundancy;
 - HR Managers need to be competent in local labour laws, and ensure that their actions in such matters are in consideration of the needs of the organisation and the appropriateness of the intention i.e. is such action necessary, have all other options been explored, discussed and offered, will the outcome be in the best interest of the short term and long term interest of the organisation, and what are the psychological and financial implications to the individual?
 - The manner in which involuntary exit is conducted is also important, and HR and area managers need to be aware of how they approach a person and the implications of their action both short and long term
 - Generally, good HR practice recommends such action, be performed after appropriate negotiation with the individual and done so in person. Via email or the telephone is not condoned as appropriate practice
 - Exit/terminations which require involvement of external authorities (i.e. contacting police in the event of theft) needs to be conducted confidentially, and carefully, in conjunction with the HR Team and suitable executive representatives.

Though HR departments may exist in organisations, it is still essential that managers and staff are directly responsible for the employment and support services of their team, to ensure systems are in accordance with professional practice. For nursing, this can be achieved by awareness of best clinical and structural practice and ensuring that they are safely imbedded within the workplace.

Generally, for higher-functioning, well established organisations, professional clinicians report to their superior who then report directly to the Chief Executive Officer (CEO) or General Manager. For example, staff nurses report to the senior nurse (bottom-top). At the top of the chain, the Director of Nursing sits equal to other Directors (e.g. medical, anaesthetic, HR and communications) and participates in strategic planning, represents their workforce, and works collaboratively to develop policies and plans and addressing issues as they arise.

This also removes conflict. For example, in some countries nurses need to raise issues about care but are afraid to, or feel there is

no point, because the internal structures do not encourage this. This not only distresses nurses but in the long term means that the services never progress and patient care remains compromised. By dividing up reporting structures, the system can debate and address issues clearly, fairly, respectfully, and in consultation with global evidence and best practice.

Such a structure may not be routine in some countries but where this is routine, services flourish, and management and service burdens are lifted from surgeons – allowing them to focus on patients and research. Staff moral also improves in these systems as staff members are empowered to not only work hard but also to support each other and collectively progress as one.

Nurses, in particular, experience stress and concern when there is a need to raise issues about other staff – and in particular, medical staff. Appropriate reporting structures and organisational cultures and systems need to be in place so nurses feel able to raise legitimate concerns with the knowledge that they will be supported. Nurses, or any staff member, should never be penalised, lose their job, or be bullied for raising clinical or practice issues.

Policies and Documents

An essential part of management is the development, maintenance and implementation of policies, standard operating procedures and other tools such as registers and logs, audit tools, reporting forms and patient chart templates.

Managers are encouraged to invite staff to comment on, or provide edit recommendations on, drafts before the final version is implemented. Depending on the item, a month or two can be a sufficient length of time. Staff comments/edits are voluntary; however, staff should be made aware that this is their chance to provide their input.

There are different levels of sign-off on an item before it can become officially available for use and implementation. Table 9.1 provides a suggestion on who should be involved in signing-off on different items.

Note: the Director of Nursing and/or an external nurse advisor

must be a sitting member of all executive and medical boards/committees, involved in policy and standard development, planning and sign-off.

Patient Charts:

While Electronic Health Records (EHR) also referred to as Electronic Medical Records (EMR) are the most practical way of storing patient data, paper versions are still routinely used around the world.

Clinical Quality Management (QM)

Clinical Quality Management (QM) refers to the conscious act of monitoring performance in order to improve the quality of service. Facilities do this so they can determine what they need to do to improve or change their practice for the betterment of the patients. The goal of QM is to provide the best possible care. Paper templates are provided in Appendix B.

In larger facilities, QM can be managed by a QM team or by one person specifically employed as the QM contact. This person works as part of the clinical executive team by liaising with the Director of Nursing, Medical Director, and Infection Control Nurse etc., to ensure quality activities are completed.

In smaller facilities, QM is generally rolled into the Director of Nursing (DON) portfolio. The DON can then divide up the tasks amongst the senior nurses within the team to ensure collectively, that the quality tasks have taken place.

Clinical QM is significantly different to population monitoring and evaluation, as activities are specific to the clinical area and require specific clinical and practice knowledge and expertise. Despite this adding greatly to the work load of the clinical team members (not just nurses), they must be involved and must be responsible for or oversee clinical QM activities.

QM can be divided into several key parts which collectively provide information on current practice and gaps. These can be benchmarked (compared) to similar facilities as a mechanism to improve practice. Data capturing periods are generally monthly, but this may depend on the type of data and the type of system in

Item	Who is involved in the final draft	Ultimate sign-off
Clinical related policies	Director of Nursing, Medical Director and other Clinical Directors	Medical Board
Patient records - paper or electronic	Director of Nursing, Medical Director and other Clinical Directors, Electronic Medical Records Expert, Finance Manager, Administrative (or reception) Manager, Quality Manager, Clinical Coding Expert	Medical Board
Clinical standard operating procedure	Area experts (i.e. Sterilization Manager and the Director of Nursing for sterilization room matters, or Optometrist & Medical Director for clinic ophthalmic equipment)	Medical Board or area Director/Manager (depending on the item)
Clinical audit tools/registers/logs	Area experts (i.e. Sterilization Manager and the Director of Nursing for sterilization room matters, or Optometrist & Medical Director for clinic ophthalmic equipment)	Medical Board or area Director/Manager (depending on the item)
Non-clinical related policy	Non-Clinical Directors (+/- Clinical Directors if applicable)	General Board
Non-clinical standard operating procedure	Non-Clinical Directors (+/- Clinical Directors if applicable)	General Board

Table 9.1: Management involvement in documentation sign-off

place. The QM designee collects the data ready for reporting to the Medical Board and the Clinical Directors who will use the data to implement clinical practice change. These divisions include:

- sub-committee management;
 - Infection Control
 - Occupational Health and Safety (in conjunction with HR in order to ensure clinically relevant safety mechanisms are included in the wider HR and risk processes)
 - Fire Safety (in conjunction with HR to accommodate clinical risk, i.e. immobilised patients and cylinder management).
- reporting (can be completed monthly or as per Medical Board requirements).
- clinical indicators:
 - incident reports
 - cancellation rates
 - infection rates
 - critical and near-miss events.
- registers and logs:
 - risk register
 - material safety data
 - prosthesis register
- audits – which generally are tools used by the sub-committees, i.e.
 - 5 Stages of Hand Hygiene audit
 - Environmental and Infection Control audit
 - Including, for example, water purity and/or air tests
 - Chart review audit
 - OT utilisation audit
 - Other audits as specified.

Additionally, depending on the country, the QM team and/or DON and Medical Director may also need to develop and/or report items to external bodies such as accreditation agencies and Ministries of Health.

Incident Reporting

For the purpose of this text, the term 'event' will be used to describe an incident – meaning, something that has gone wrong (deviated from normal or expected practice).

When an event occurs, i.e. a medication error, lost equipment, theft, a patient fall, or if the surgery was performed on the wrong eye, then it is important that they are reported. This ensures the event is documented for legal reasons as well as ensuring it is followed-up (steps taken to correct the issue). Reporting is also used to examine how the event happened and how it can be prevented in the future.

There are different reasons why events occur. Many may appear to be the result of an individual, however many, on analysis, are a result of the system and culture at the facility – which the individual tries to function within. For that reason reporting is vital to help improve the system.

In the past, some people have been afraid to report events as they fear it may make them look bad or it may jeopardise their job. Some involved (even managers) have tried to prevent events from being reported, and some have gone as far as penalising individual staff members who report events (sometimes called whistleblowing). This is unfortunate because healthcare, and healthcare teams cannot improve unless there is openness and honesty regarding issues, and a genuine team approach to improving the system.

Today, reporting events is encouraged, and competent managers

welcome and support employees to submit reports.

In general, an event needs to be addressed when it occurs, with those in attendance, at the most suitable time, after (or during rectification of the event). The manager needs to be notified and then an incident form completed. Every country has a different name for an incident form but generally the form asks for details of the event, such as:

- date and time of event
- name of the person submitting the report
- who was involved (i.e. patient and/or staff member names)
- details of what happened
- details of how the event was managed and who it was reported to.

Once the form has been completed and submitted to the manager, it goes through a system of review – often by the quality or governance committee, who then explore if the event is an isolated issue or something that can be fixed, and prevented in the future. They use the event as a positive opportunity to change policy and/or re-educate staff or purchase new equipment (event dependent).

Material Safety Data (MSD)

Material Safety Data (MSD) refers to information retained by the facility about products (usually liquid based, i.e. cleaning products) they purchase. This data is retained to assist staff with storage and safe handling. It also contains information about the risk of the product, and how to manage incidents such as a splash injury or spillage.

Information regarding each product is obtained from the product packaging, manufacturer or the product's website and is generally collected and placed in one area (either on paper or electronically) and is easily accessible to staff in an emergency. Copies can also be placed close to where the products are stored or used.

Occupational Health and Safety (OHS)

Occupational Health and Safety (OHS) – sometimes called 'workplace health and safety', refers to a management system which seeks to ensure a workplace maintains a safe environment for staff, visitors and patients. By doing so, the organisation is assured that known dangers have been removed. This is a risk reduction strategy.

The system can be managed by a specific OHS Manager or team and/or the Director of Nursing – depending on the size of the organisation. Some of the items that the OHS Manager or designee will monitor are outlined within this section (adapted from the OHS policy for the Fred Hollows Foundation NZ, 2015). These are essential for all staff to be aware of, regardless of their position.

What staff need to know about OHS

Firstly, it is important that staff look after themselves in the workplace. This can prevent life-changing injury. If injured at work, staff may have to reduce their work load or leave work – which could have a disastrous effect on their family (i.e. loss of income). If staff are injured, it also means that other team members have to do more work to accommodate absent staff or those placed on light duties. Anything that can be done to prevent injury is important.

Read the hospital's OHS policy

The OHS policy outlines the hospital's approach to health and safety in the workplace. This is a major component of the risk that hospitals actively manage on a day-to-day basis. This policy is generally

supported by other country/regional guidelines or legislation, and accompanied by the hospital's incident reporting system. Additionally, various risk registers and checklists accompany the OHS Policy.

Safety is for everyone including: employers, employees, principals, contractors, sub-contractors, people with responsibility for work and work places, volunteers doing work activity, people receiving work experience, people receiving on-the-job training, people working from home, and mobile (outreach) workers.

Identifying risk in each area

Developing a risk register (as outlined in Table 9.2) can alert the team to possible issues. This can be used to help prevent problems and assist staff during situations that might arise.

Consequence	Likelihood				
	Very likely	Likely	Possible	Unlikely	Highly unlikely
Fatality	Extreme	Extreme	Extreme	High	Medium
Major injury	Extreme	Extreme	High	Medium	Medium
Minor injury	High	High	High	Medium	Medium
First Aid	High	Medium	Medium	Low	Low
Negligible	Medium	Medium	Low	Low	Low

Table 9.2: Risk Register

The risk levels, in Table 9.2, help to prioritise each hazard based on its risk. The levels show how important it is to do something about the hazard, i.e.

- Extreme and high risk – it is extremely important to do something about this hazard immediately.
- Low – this hazard may not need your immediate attention, but it should be rectified as soon as practical.

A risk register can be applied to work environments, tasks and even products.

Some key points to remember

- every person has a responsibility to keep themselves and others as safe as possible
- do not take short cuts on safety.

Focus on

- **Prevention** - i.e. wearing gloves, washing hands, ensuring the environment is clean, including machines and equipment on maintenance schedules. It also means that staff are educated on safety in the workplace.
- **Use risk assessment skills** - to try to control and prevent an issue from occurring via "Control Measures". Table 9.3 provides an example of some control measures that can be implemented in the facility.

Managing events - i.e. if something happens, report it and help to rectify the situation as soon as possible (within own scope of practice) such as;

- never place each other in harm's way
- 4 key points are:
 1. identify the hazard

2. gather as much information as possible about the hazard (risk assessment)
3. develop and implement a solution to the hazard (hazard control)
4. look back at the hazard to see if it has been solved or has created another problem (review).

Follow-up after the event – Complete an incident report, talk with the team about what happened, and help find a way to prevent it in the future. Use the event as an opportunity to educate others.

(Fred Hollows Foundation NZ, 2015)

	Control Measure	Examples
	Elimination	Redesign a job to remove an unsafe work practice, e.g. replace noisy equipment
	Substitution	Substitute a heavy piece of equipment for a lighter piece of equipment, use a less toxic chemical
		Use electronic swipe cards or keys and locks to restrict access to work areas
	Engineering means	Provide trolleys to move heavy loads, install guards on moving parts of machinery
	Administrative means	Provide training, guidelines, instruction or information, change daily routines to give breaks from repetitive tasks
	Personal protective equipment	Provide gloves to prevent exposure to blood and body substances, hearing and eye protection, safety footwear
Least Effective Control		

Table 9.3: Risk Control Measure

Looking after the area

- **Communal areas - i.e. kitchen, meeting rooms, patient waiting areas** - These areas, especially the kitchen can be dangerous places. Staff need to be diligent, to prevent and report possible issues. Be careful in this area because both water and electricity are commonly found in the same space – their mix can be dangerous.
- **Maintenance areas** - i.e. gas cylinder areas, cleaner's cupboard, biomedical workshops and boiler rooms. Be extremely careful in these areas. Only enter with permission from the maintenance team. Heat, chemicals, electricity and water may all be hazards. Strict approved-authorisation-only should be enforced.
- **In the office** - Look after computer electrical cables and make sure computers and other electrical equipment cannot overheat. Be careful of tripping over items on the floor. Have chairs at a good height to the tables, to prevent back injury.
- **In the clinic** - Clear the pathways for patients. Make sure equipment and stock cannot be tampered with. Have hand-wash and gloves available in each room. Clean equipment

between each patient, and clean the whole room at the end of the day. Follow Laser Safety policies when using lasers.

- **In the OT** - Similarly to the clinic, ensure the area is clean and tidy. Extra care needs to be taken in this area because there are often more machines (meaning more electrical cables). Make sure staff are trained in correct manual handling to prevent injury when transferring patients and moving items. There is also the increased risk of personal injury due to blood and body fluids. Ensure PPE is worn.

Wearing Personal Protective Equipment (PPE)

PPE is important. This includes wearing of masks, aprons, gloves, suitable shoes (which cover your toes and provide heel support) and other items, such as lead-aprons, if working in the radiology department. Other important key items are laser safety goggles when using a laser.

Be aware, when using gloves, that hands still need to be washed before and after. Spraying the gloves with alcohol hand wash will not keep them clean. Take gloves off and wash hands. Gloves also need to be a suitable length.

Glove selection also includes the type of glove material and the length/size of the glove, for example:

- Wear longer gloves when working in the sterilization room, as water often enters wrist length gloves
- Wear heat resistant gloves where there is the potential for burns.

Many gloves have latex inside them – and can have powder too. While products containing these were popular many years ago, several countries have stopped using them because staff (and patients) can become intolerant to latex after long exposure. Powder is not ideal for eye care, so, if using powdered gloves make sure the powder is rinsed off before starting the surgery. This is to prevent powder particles getting into the eye during surgery. If budget allows, avoid latex and powdered gloves.

Remove slip and trip hazards from the floor

If there are any pools/puddles of fluid on the floor then please mop them up immediately. This is to prevent someone from slipping and falling (this is especially important when patients and visitors to the facility are vision impaired). If it is something acidic or a dangerous chemical, please wear PPE and follow the hazardous material (Hazmat) recommendations for cleaning. This will prevent injury (i.e. prevent a skin chemical burn) and damage to the flooring.

Many facilities have 'wet-floor' signs that can be placed on the wet floor area until it is cleaned up or it dries. This will help prevent people from slipping in that area.

If any electrical cords or anything else sticking-out is noticed, immediately secure it or tidy it away. This is to prevent someone from getting their feet caught and tripping over.

Body care and ergonomics

Always look after the body when at work. This means careful lifting or moving of an object (including a patient) and/or doing repetitive movements. Here are some good tips to apply:

- always ask someone to help move or lift an object that is heavy or difficult
- never twist the spine. Keep it straight
- push rather than pull
- keep heavier items at good body height level, i.e. not on a

high shelf or low shelf

- use stomach muscles (core) and legs to lift and push up – avoid using the back
- get close to an object so it will make it easier to move it
- wear body braces (if available), such as lifting belts.

(Machin, 2012)

Note: for nurses and technicians, it is recommended that they attend a course on how to move and handle patients as these procedures require special training to prevent injury to the patient and staff.

Avoid repetition injury

This happens when staff continue doing the same movement, in the same position, for extended periods of time (e.g. people in an office sitting at a desk and typing, a scrub nurse standing in one spot all day, or the sterilization room member leaning into a deep sink). The key is to prevent these repetitive actions leading to strains, aches and, in some instances, severe pain. Here are some suggestions on how to prevent this:

- Move around between jobs: e.g. an office worker should get up, at least once an hour, and stretch their legs and flex the arms. Perhaps they can alternate typing work with other work, such as standing up and chart filing.
- Try and alter tasks: e.g. a scrub and circulating nurse can swap jobs periodically, so they are sharing the 'standing' work of the scrub position. Team work is the key here.
- Change the environment: e.g. the sterilization room needs to be designed or modified to prevent the staff from having to lean so far forward. This will help to prevent back injury.

Be aware of the path of organisms and disease transmission

Safety also extends to preventing the spread of infections in order to prevent the spread of organisms – especially in a healthcare facility where there may be people with lower immune systems. Tips to prevent the spread of organisms are outlined below.

Hand hygiene

Implement and follow the World Health Organization's 5 Stages of hand hygiene campaign. Please see section 1.

Waste and linen management

Follow the policy on waste and linen management by ensuring contaminated used items are removed (and/or disposed of) correctly. Wear gloves and wash hands after touching.

Cleaning

Remember to wash equipment between patients and again at the end of the day. Certain items, such as curtains, still need to be cleaned, but not every day. Check the policy on when these need to be cleaned (i.e. monthly, quarterly, or bi-annually).

Prevent needle stick Injury

Healthcare workers, and especially nurses, can obtain a needle stick injury if they do not practice safe sharps-handling.

If a staff member gets a needle stick injury, they need to immediately notify the manager and follow policy. Many countries will have guidance procedures which include collecting of blood samples from the patient and/or staff members involved. Blood tests help to confirm if an infection has been contracted as a result of the injury. Completion of an incident (adverse event) report will also be needed.

The best action is to prevent a needle stick injury from happening in the first place. Here are some universal recommendations to prevent this;

- Never re-cap a needle.
- Never take a used needle from the hand of another person (take note: scrub nurses). Instead, ask the person to place the sharp item into a needle-container where it can be clearly seen. It is then transferred to a secure area or a sharps container.
- When rostered as the scrub nurse, never pass a used needle or sharp blade to a surgeon when they are distracted. Make sure the surgeon is informed when they are being handed a sharp item.
- Never pass a blade or hypodermic needle with the sharp end towards the surgeon and do not accept a blade or hypodermic needle if it is passed back in the same manner.
- Blades are to be handled with a special forceps that is strong enough to grasp the blade for placement onto and off the handle's shaft. Never use fingers. Alternatively, a blade remover can be used.
- Only fill a used sharps container to the fill line.
- Never grab or stick hands inside any bowl or container without looking first. This is to make sure items (i.e. suture needles) have not been accidentally left inside.

Education

Providing education to the staff is an essential element of all facilities. Depending on the size of the organisation, this can be done via the managers or via a specifically designated nurse educator.

Many organisations provide staff with mandatory training, i.e. fire-safety, or training specific to their profession, such as a hand-wash refresher. Additionally, training can be individualised to support the needs of the specific employee, i.e. one team member may ask for extra time to learn or gain knowledge in a specific task/skill.

The "training delivery" can also be divided into several methods. Such as:

- In-service training: Where the OT manager ensures that staff are kept well informed of new ideas, equipment and surgical techniques that may be introduced to the OT.
- External training: This is provided by specialists and/or other clinical training providers, i.e. course-work and online learning.

It is the OT manager's responsibility to plan and arrange in-service and external training, when appropriate, to encourage potential and further staff learning. Assessments can be useful for measuring staff progress and development.

While the employer may provide some training, the individual employee is responsible for their own learning. It is impossible for the employer to provide employees with every new update. Therefore, staff are not restricted to just completing employer-provided training. They can study other course work in their own time and at weekends, on whatever topic they are interested in and enrol in peer associations.

New staff

An induction pack needs to be provided to all new employees on the first day of work. The pack contains information about the facility, department, staff profiles, contact details, clinic/OT sessions, shift patterns, uniform policy, common procedures, OT terms used and

recommended reading, and the HR policies and processes.

An induction programme about the hospital also needs to be arranged as part of the orientation process for the new member(s) of staff. The programme needs to include mandatory training such as infection control, health and safety, manual handling, safety training for vulnerable adults and children, medicines management, fire safety and other information necessary for the staff to be aware of best practice.

CPR: Many facilities around the world expect all clinical staff to be trained in basic life-support (Cardio Pulmonary Resuscitation-CPR). While this is not routine in some lower resource locations, it is advised that all facilities explore the possibility of providing this training.

If a specific CPR trainer is not available, talk to the anaesthetists and/or emergency department staff to ascertain if they can help provide training on the basic principles. Generally, staff need to re-train on their CPR every 12 months.

When a new member of staff is allocated to the department, they should have a designated mentor, and be provided with set learning objectives. The objectives should cover the basics of sterility, infection control and patient care in the OT. These help to set a standard of work that is achievable during the probationary period.

Probationary period

A probationary period is a period of time given to new employees to allow them to learn the system and settle in. It also allows the manager the chance to determine if the staff member is performing as expected and to standard. The length of time can vary depending upon the workload, the staff member's previous experience and the rate of progress in learning. Generally, three months is recommended, as this gives the OT manager a good idea of the employee's standard of work, and is sufficient time to settle in to the team.

The OT manager should arrange a preliminary interview during the first month. This will enable the OT manager the opportunity to assess the knowledge base and skills of the new staff member and identify any training needs.

At the end of the set probationary period, depending on the performance and progress in the OT, the facility can determine if they will retain the employee or not.

Mentoring

Mentoring is another method employed at facilities around the world. In this process, an experienced and reliable staff member – who is able to support new staff members, is partnered with the new employee.

The mentor – who is someone acting as a positive role model - must be skilled and knowledgeable (Royal College of Nursing, 2007). They must be responsible for developing the new recruit's knowledge, skills and confidence, through a process of learning during the probationary period. The OT manager can also assess the mentor's teaching competence. Non-patient contact time should be provided to the mentor and staff member so they may explore and discuss non-clinical aspects of their position.

In order to provide a supportive learning environment, it is essential that both the mentor and the new employee work towards the same goals and within the same system. Table 9.4 provides an example of a framework from the Nursing and Midwifery Council in the UK.

The framework to support learning and assessment in practice

1. Establishing effective working relationships
2. Facilitation of learning
3. Assessment and accountability
4. Evaluation of learning
5. Creating an environment for learning
6. Context of practice
7. Evidence-based practice
8. Leadership

Table 9.4: Mentoring Framework. Source: Nursing and Midwifery Council (NMC), 2008

Probation practical instruction

Practical training can be carried out initially by the mentor during the probationary period. The new recruit learns by watching and listening and will gain the confidence needed by being with the more experienced colleague. Slowly they begin to take an active part in procedures. The experienced person should always be at hand to offer support. This can take several operating sessions but has been found to be a very effective and safe way of teaching. The surgeon should be informed that a new colleague has joined them at the operating table.

End of probation assessment

In some situations and for some skills/tasks, assessment may be needed. The assessment can take place at the end of the probationary period and needs to be based on key objectives presented at the commencement of employment. This assessment should be based on both knowledge and skills, and examine their ability to apply theory to practice. Professional behaviour including attitude, teamwork, caring skills, appearance and motivation, should also be assessed (Royal College of Nursing, 2007). If these assessments are successful, mentoring in a supervisory role can continue.

The mentor (via the nurse educator and manager) needs to ensure that assessment is:

- not biased and without personal favouritism and agenda
- written/designed in a manner and language that fits the level/type of employee
- not designed to trick the employee and/or set them up to fail.

Note: assessment can be via a competency sign-off sheet or a questionnaire. Either way, the assessment item needs to be measurable and operable on all employees in that position. A competency template is provided in Appendix B.

What to be mindful of when assessing:

- Assessment can cause anxiety and thus reduce the intended “realistic” outcomes.
- A mentor’s own teaching style and behaviour can cause stress or confusion to the employee. Ensure a good relationship has been developed. If there is a personality clash, the mentor needs to identify this and take this into consideration (i.e. non-bias) when assessing. If the mentor is unable to provide this unbiased professionalism then another mentor must be substituted, to ensure equity and fairness for the employee.

Continuing education

Once the probationary period has finished, it does not mean the end of training. Training and education are ongoing for all healthcare professionals. Reinforcement and encouragement is essential for successful continuing education.

If possible, the hospital should allocate one member of staff to be responsible for the coordination of in-service training. Alternatively, the OT manager must be responsible for this, with assistance from other experienced staff. It is imperative that the person, who is responsible, enjoys teaching and sharing their skills with other adults. Some people are very good at teaching whereas others are good at their work but do not enjoy teaching. It is important that the OT manager considers the opinion of the ophthalmologist and other team members so that the appropriate person can be appointed.

In some facilities, staff are encouraged to keep a diary so that they can reflect back on what they have learned and what they need to do to improve. The Gibbs (1988) model of reflection (Table 9.5) is an example of reflective practice and incorporates the core skills of reflection. Gibbs uses a series of 6 questions, which form a “cycle” of continual self-evaluation and improvement.

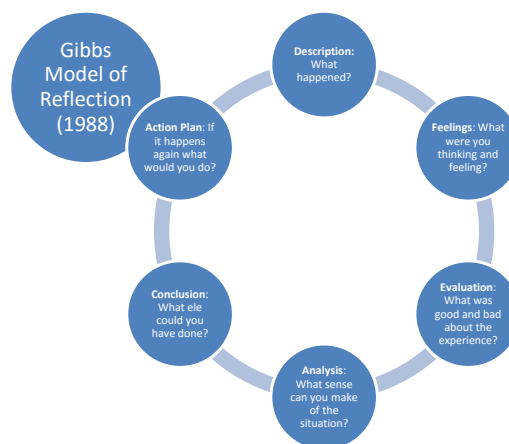

Table 9.5: Reflective practice and incorporating the core skills of reflection. Source: Gibbs (1988) Learning by Doing: A guide to teaching and learning methods.

Formal courses

A formal course can be run at the facility, covering both practical and theoretical topics, and centred on the work that is being carried out by the facility. Such a course needs to have an appropriate and well-structured curriculum – often accredited with a learning institute or professional body. Communication and administrative skills should also be taught. This type of course requires considerable commitment from all parties.

Alternatively, non-formal courses can be developed, which are the same as a formal course but without peer/sector accreditation and/or assessment.

External training

Many organisations, professional associations and healthcare facilities offer training from non-formal to formal in a variety of topics. This can be either a conference, workshop, hands-on simulated training events, book work or via online methods.

Working with an external body will allow attendees the opportunity to bring back a wealth of knowledge to share with their colleagues.

Prior to staff enrolling in external courses, the OT manager needs to determine the relevance of any external training, the budget

available and staffing levels during absence, in order to allow attendance (if during work hours).

Teaching and learning resources

There is now a wide range of low cost teaching and educational materials available. Many of the industry i.e. suppliers/companies, even in lower resource locations, make resources available, i.e. posters relating to eye conditions, and anatomical cross-section models. These can be displayed in the ward and clinical areas, and used as teaching tools and references throughout the facility. Eye models are becoming cheaper and are an excellent way of demonstrating the anatomy of the eye. Drug and medical equipment companies also provide free training and information. The internet is a good learning tool for those who have access to it. There are several free sites that offer information about eye healthcare.

Theatre manual

A local OT manual also needs to be available. This discusses different types of operations and provides copies of policies and work instructions. The manual can be updated when new surgical methods are introduced or a new piece of equipment is purchased. The manual can also be used as a teaching tool for new members of staff.

OT in-services

Teaching sessions can be arranged in the OT, where a member of staff is allocated a topic (type of disease, evidence-based surgical procedure or new equipment/instruments) to be discussed among their colleagues. These sessions encourage and motivate staff to learn more about their specialty. Equipment representatives can also be present at these sessions.

Classroom/library or quiet area

Libraries allow nurses and other staff members the chance to meet, discuss and/or read a journal article or text. If the facility is a tertiary centre, a library must be available to all staff and any visiting undergraduate students.

“Life-long learning is an essential part of a personal and professional development.

Reflecting on practice and learning from experience will result in high standards of care to the patients/clients” (Vaughan, 2013).

Supply Chain Management (SCM)

The facility must store and maintain enough supplies in order to meet the demands of in-patient and out-patient surgeries. If stock levels are not maintained it is not possible to run a successful department.

Stock management refers to the ordering, receipt, storage, dispensing, disposal and tracking of all items (stock) that move through a facility and a department. Stock is equivalent to cash sitting on a shelf and represents a significant financial investment (asset), and risk, if not managed well. Without strong stock management systems, departments can face issues such as under- or over-supply or wrongful purchase of stock – all of which can jeopardize services. This could mean that surgeries are cancelled or rescheduled, or that care is compromised with inappropriate use of available stock. Finally, it can also cause frustration to staff.

Stock control and stock inventory practice should be maintained as two separate items so that they can be used to cross-reference against one another. This cross-reference is important as it allows the facility – generally, via an appointed Stock Control Person - to

monitor stock levels, purchasing needs and costings.

The next section will explore some of the key proponents of stock management, including purchasing, managing spare parts (back-up system), payment, controlling the stock, inventories, consumables and storage.

Purchasing and procurement

There are two avenues for purchasing which need to be considered as they will determine how quick and how easy it might be to receive ordered items. These are:

- Local purchases - those that are already available for purchase in the country of origin;
 - suggestion: purchase two months' supply in advance and try and retain stock levels as two months' worth. This will buffer against any global/regional import issues.
- Overseas purchase - those that need to be brought from outside the country;
 - suggestion: purchase six months' supply in advance and retain a stock level of 6 months' worth

Before purchase, check that the items being ordered are legally allowed in the country and if there are any import and custom's taxes that will be applied. These will all add to the time and cost it takes to receive the items.

It is important that the OT staff and stock management teams communicate regularly and notify each other of delays and product issues.

Planning

It is also important to consider holiday times – such as Christmas, Diwali, Eid al-Fitr, etc. - because receiving stock may take longer. Therefore, additional stock should be ordered or more time should be allowed for the goods to arrive. Some other key purchasing recommendations include:

- Order in bulk. This often reduces the price and reduces the workload for the stores team reordering;
 - note: remember, while bulk ordering is good, if it is over ordered and the stock is not used in time, it will expire. Therefore, calculate the consumables' usage rate, against the surgical time table of how many items may be needed for a specific period, i.e. of no more than 6 months. It is important to ensure that the item's shelf life is more than six months by the time it is received. If it is over ordered, and the stock expire' before it is used, then it is a financial loss to the facility. This needs to be avoided.
- Maintain an accurate register of local and overseas suppliers with details of their representatives name, addresses, telephone, e-mail and fax number. Ensure that this is kept up-to-date.
- Request new price lists and brochures each year.
- Maintain a register of all products that are required from overseas, and ensure that overseas purchasing is completed before the last box or unit is used up.
- Know the country and health system's legal import laws and confirm if items are registered (licensed) or need to be registered in the country or not, i.e. items that are not allowed may not be released from customs.
- Procure best quality instruments and items that the budget will allow. Good quality equals longer lasting and less risk to the patient.
- Ensure spares such as bulbs, fuses, and consumables are

budgeted for when purchasing capital equipment. Consider procuring equipment with LED technology so that spare bulbs are not required.

Capital equipment (asset) purchases

Procurement – which is the actual act of buying the items - can be for equipment as well as consumable supplies. When considering equipment purchases, depending on the size of the facility, it may need consultation with the accounts team and/or nurse manager because such items are considered capital (asset) purchases, and a special purchasing system – called a purchase order - may need to be signed off or generated.

For a purchase order, the manager or designee may ask to see some quotes so they can make an informed purchasing decision. Here are some other considerations when purchasing equipment and larger items:

- Prior to purchasing, check with the relevant medical/nursing/technical experts and end-users in the team to confirm the item is suitable for purchase.
- Determine the long term maintenance and service (cost and time) required for the item, i.e.:
 - are biomedical engineers needed to install and/or maintain it long-term – are these experts readily available?
 - can spare parts be purchased in the country?
 - never buy a piece of equipment without at least one year's supply of spare parts. Ask the manufacturer which spare parts may be needed in the first year
 - does the item require the purchase of accessory (compatible) items long term (i.e. diathermy cords or phaco packs for a phaco machine)? Factor the cost within long term budgets. Some questions to ask when planning the budget may include;
 - can those accessories/consumables be easily obtained in the country?
 - is the cost sustainable in the long term? Does anyone know how to set it up and maintain the equipment? Do training sessions need to be arranged?
 - the manufacturer may consider sending a representative to set up the equipment, and give a demonstration to the staff on usage, routine maintenance and long term care, service, etc. This may be an extra cost, which needs to be considered when budgeting.
- Can the equipment be safely cared for? i.e. if it is temperature sensitive, can it be kept to its desired temperature?

Spare parts

Every facility needs to have an adequate stock of spare parts to maintain functioning equipment. These spare parts range from ophthalmoscope bulbs and fuses to suction machine motors.

It is good practice to check the stock level of spare parts and liaise amongst the team about purchasing needs. The OT manager and the store's manager should routinely discuss/check-off spare parts in their regular meetings and/or checking systems.

It is recommended that one person/department be responsible for maintaining an inventory list in bin cards of spare parts, catalogue and order numbers, list manufacturers, and conduct the purchases so that orders are placed in good time.

Stock control: incoming items

All stock that arrives into the facility should go to a central store where the storekeeper/stock manager checks the delivery against the order and delivery note. If there are any discrepancies, these are noted and reported immediately.

Stock cards

Once the goods are checked and known to be correct they need to be documented on stock cards or on an electronic system. The card should hold the following details.

- brand name of equipment/item
- generic name of equipment/item
- other details of the item: i.e. volume or strength for a drug
- expiration date if applicable
- equipment serial number (necessary for the facilities insurance policy)
- cost of item
- date of purchase
- manufacturer's details
- where they are stored in the facility, e.g. store room number 2, shelf number 4
- spare parts required for its maintenance
- quantity received
- quantity issued
- minimum stock level
- bin card number.

(Please see suggested layout of a Stock Control record card in Appendix B).

Stock cards should be kept for all stock and equipment that leave the storeroom for the wards, outpatients, OT, and outreach. These cards can be submitted to the nursing director or designee when considering requests for new supplies.

Monthly consumption figures for each stock item should also be recorded. This is helpful for planning.

The designated stock manager is responsible for re-ordering items so that stock does not run out before their next delivery. This administration may be helped by the use of commercially available electronic stock management systems.

Inventories

Inventories are simply logs that list items, equipment and furniture owned by the facility. Mostly this applies to capital (fixed) assets, but can also be applied to consumable stock.

The logs can be used during stocktakes to determine count numbers, missing items, usage and ordering needs. Use of stock variation forms are an additional tool that can be used to monitor this.

Consumables

Consumables are items that are thrown away after use. Once used, they cannot be counted, and are considered as a direct expense. Monthly and yearly sheets, summarising items used over the period, can be used for planning and ordering purposes. Therefore, a record of usage needs to be maintained. Very importantly, the expiry, sterility and shelf life dates should be noted.

Storage of sterile stock

When the items enter the ward or OT etc., they need to be placed in their designated storage space. A general rule is that new stock is placed to the back so that older stock can be used first (first in – first out): this is called stock rotation. (An alternative to this is, new items to the left and old items to the right, or vice versa.) In principle, as long as everyone in the team follows the same rules, then there is adequate rotation, and in theory no items should be wasted.

Sterile stock must be stored in a manner that maintains sterility and prevents contamination.

Storing stock in a clean, well ventilated, temperature controlled room away from sunlight, water sources and dust, will protect them from damage. Ideally, stock should be kept on wire racks or shelves (not too close to floor or ceiling) to allow airflow around the items.

To help make the stocktake and general use easier, the stock should be stored in groups e.g. all needles grouped together, and all dressings grouped together etc. The shelving should be labelled and stock kept uncluttered. Other key ideas are to:

- keep all sub-specialty stock in one area (i.e. cataract in one shelf/area and retinal in another)
- do not put heavy items too high or too low – remember good back care and work place safety
- do not overfill the shelves and containers.

Stock in the OT

Stock stored in the OT must be kept in an area that is clean and away from any possible contaminants e.g. blood and body fluids. Only regularly used stock should be stored in the OT - such as needles, sutures and gauze. Too much unnecessary stock will create clutter and make cleaning difficult. Stock levels should be kept to a minimum and when restocking, expiry dates should be checked with older items placed at the front.

Avoid retaining outside cardboard boxes in the OT as part of the infection control risk prevention strategy. Instead, transfer items into plastic or metal (both cleanable) drawers.

Conducting a stocktake

Stocktakes should be conducted on a monthly basis to assist the stock manager with ordering new stock, and to minimise stock wastage.

The stocktake process should be standardised across all departments and a number of staff should be familiar with the process, not just one individual.

When conducting a stocktake, all items must be counted, and expiry dates checked and recorded. The stocktake form should have a minimum stock level for each product which alerts the staff to the need for reordering. Once the stocktake is complete the form should be sent to the stock manager who can then order (or remove from storage container) the necessary items.

Recall issues

Occasionally, manufacturers may ask facilities to return stock which they have discovered as dangerous material, due to manufacturing damage or malfunction. Alternatively, the manufacturer or facility can return an item that is broken on arrival or has the potential to cause harm in some way. When this happens, a Recall event is activated. Staff need to immediately remove the offending item(s) so it/they cannot be used – and cannot cause harm (or be opened and charged out as a cost to the facility). The items need to be

isolated, an incident report completed and all details given to the Store Manager or designee. The Store Manager is then responsible for liaising with the manufacturer to return the items, report issues, and arrange for return of money, replacement or the provision of a credit note.

In the instance of recall issues, from time-to-time, particular stock items may not be available until the issue is resolved. Therefore, all medical and store team members need to work together to find alternative products until their preferred product becomes available again. The medical team needs to be flexible during this time.

Payment guidelines

Payment of stock varies around the world, and between facilities, but in general, the finances will be extracted from one facility/department account and transferred to the supplier. Sometimes agreements (called Service Agreements) can be developed between the facility and the supplier, and automatic payments can be made. At other times, payments are manually transferred by a member of the accounts team. Either way, payments need to take place under the direction of the account management team.

Where the money comes from also depends on the facility and its affiliations, i.e. public (Ministry), private or benevolent facility, donor or patient paid.

Another variance is “when” the payment is made. Some suppliers request 100% up front, some part-payment while others may agree to be paid afterwards.

From the nurse perspective, it is important to:

- Ensure Local Purchase Orders (LPO) are signed by the stock manager, OT manager or their designee.
- Delivery notes from the supplier are checked against the LPO to ensure the quantities and descriptions or specifications match. This needs to be signed by the person delivering the goods and by the storekeeper. Some other considerations are:
 - orders should not be paid until the documentation is received and noted as correct
 - goods are checked and signed as being received (Goods Received Note)
 - invoices and payments are routinely checked against a statement of accounts provided by the supplier. This is often done monthly and quarterly (every 3 months).

Health Information and Data

This section will provide information on the obtainment and interpretation of data.

Why patient data is captured

The primary purpose of capturing data is to use it to support patient care, and ensure there is coherence of care along the expected care pathway.

Good health information systems have a positive impact on patient autonomy, epidemiological and clinical research and evidence-based error reduction, and can potentially reduce healthcare costs. (Gummadi et al, 2014; Bowman, 2013; Shekelle et al 2006.) Conversely, the absence of accurate and complete documentation in patient medical records can have a negative effect on clinical preparedness, statistical databases, financial planning, and gross revenue for the healthcare organisation.

Data shapes evidence-based policy and planning because it can provide synthesised information relating to comparative risks, investment cost and benefits accruable for individuals, or the population. Eye health-related data, sourced from individual patient information, is essential to advocate for and plan allocation of resources; at national level by governments and at the global level by the World Health Organization and the International Agency for Prevention of Blindness. (Universal Eye Health: a global action plan 2014–2019.)

Health information is recognised as a building block of the health system. It is key to the accurate tracking of health progress and performance, evaluation of impact, and ensures accountability at professional, country and global levels.

A well-functioning health information system is defined by the World Health Organization as one that ensures the 'production, analysis, dissemination and use of reliable and timely information, on health determinants, health systems performance and health status'.

Nurse/technicians role

A patient's record should include any and all documentation that relates to the care of the patient during the patient's stay or encounter. This almost always includes identification data and contact details, followed by:

- Information pertaining to the patient's history, but more importantly, pertinent information regarding the patient's current condition.
- Symptoms and any differential diagnoses.
- Findings from a relevant and thorough physical examination.
- Results of laboratory and other diagnostic investigations.
- Final diagnosis (sometimes including the relevant ICD code).

In the inpatient setting, additional pieces of documentation include:

- Orders for all treatment and care that the patient receives.
- Notes regarding the progress that the patient is making such as response to testing, treatment, and medications.
- Notes on observations or advice made by other consultants; anaesthetists, and pathologists (in the case of patients undergoing surgery), and sometimes also radiologists and cardiologists (responsible for interpreting diagnostic test results).
- Other clinical documentation provided by nursing staff (nursing notes) and other ancillary clinical staff who may be treating the patient, e.g. a nursing note which documents a patient's post-operative pain level. This assists the attending surgeon and/or anaesthetist to determine if any unexpected levels of pain necessitate investigation of the cause and/or whether additional treatment is needed to relieve the pain.
- The significance of ancillary test results (lab, radiology, etc.).
- Procedure reports, including operative reports by the attending surgeon that document every possible detail about the procedure.
- Addition of working or differential diagnoses - any conditions that should be defined as "possible," "probable," or "rule out" - and relevant alterations in the care plan.
- A copy of the discharge summary and referral letters, if any. The discharge summary should at a minimum, contain:
 - admitting and definitive diagnoses
 - summary of patient's course in hospital
 - instructions about further management as an outpatient, including any medication and the length of administration and planned follow-up.

While it is often the physician who is ultimately responsible for the patient – and the documentation, it is the nurse or the technician who is responsible for ensuring documentation has been completed so that care can be planned in accordance with documented evidence of the patient's progress and needs. Therefore, capturing and compiling patient information is, in reality, the responsibility of every individual in a team.

In the OT setting

Best practice guidelines for the OT require documentation of (WHO Surgery Publications, 2016):

- An admission note/pre-operative note, including:
 - patient identity
 - procedure to be performed
 - persons involved
 - complications or co-morbidity of relevance, such as allergies etc.
- The operative notes, include:
 - Safe Site Surgery check sheet
 - Nurses's notes – detailing, surgery times, counts, names of those involved, and items used (i.e. type of dressing)
 - Surgeon's notes - details of the procedure and complications, as well as how these were managed; usually written by the attending surgeon
 - Anaesthetic notes
 - Other, i.e. prostheses list and specimen log (if required)
- Post-operative notes
 - (organised in the "SOAP" format), including:
 - **S**ubjective - How the patient feels
 - **O**bjective - Findings on physical examination, vital signs and laboratory results
 - **A**ssessment - What the practitioner thinks
 - **P**lan - Management plan; this may also include directives which can be written in a specific location as 'orders'.
 - Recovery and discharge.

For cataract surgeries, in particular, a valid format for tracking surgical quality is available as both a manual (paper-based) form, as well as an electronic version. (Limburg, 2002.) This format can easily be adapted for any surgical procedure on the eye.

Using clinical data for research

The availability of large amounts of clinical information has prompted exploration of how this data can potentially be used for research. A challenge of conducting research that relies on routinely collected patient information stems from the absence of standardised data collection, and data governance concerns relating to the transfer, storage, de-identification, and access to electronic clinical data. (Lopez et al, 2012.) The attitude of clinicians towards secondary applications of clinical information they have gathered, or are responsible for, is another barrier to consider. (Morrison et al, 2008.)

Where computer systems are used, the Information Technology (IT) infrastructure must be available at the facility, in order to manage and maintain the computer (IT system) and ensure that the data software has been loaded correctly. Some software also needs regular updating and system back-up so it is essential that these have been planned, and personnel, with the necessary expertise, take responsibility for its upkeep and maintenance.

Staff need to be trained in how to input data and use the information generated.

Managers may need to routinely review the data and staff utilisation, in the early days of implementation, in order to determine if the data is being entered correctly, and to address any problems encountered. The transition from paper to electronic system also needs to be considered and planned for.

Understanding health informatics (advanced additional reading)

The World Health Organization defines Health Informatics as the 'discipline of using computing, networking and communications – methodology and technology – to support the health related fields, such as medicine, nursing, pharmacy and dentistry'. Clinically relevant numeric data and textual information may be captured, in the hospital or health facility setting, as a paper-based or an electronic health record (EHR). Additional data may be captured for administrative purposes; such as medical billing (coding) or as a logbook or register maintained at an OT or other such procedure rooms. Together, these various and not often interlinked repositories of health information form the basis of health informatics. Health informatics involves optimising resources and methods for the appropriate and innovative application of the concepts and technologies of the information age to improve health care and health (Standards Australia, 2016).

Thanks to new technologies, the health sector has rapidly expanded the data it can capture. Beyond traditional medical records of patients, it now includes electronic health records (EHR), personal health records (PHRs) and sources such as purchase invoices, store inventories, environmental data and social media data, some of which may be related only indirectly to the delivery of health care.

With increasing emphasis on data sharing (Pisani and AbouZahr, 2010), and the reality of 'big data' available within other repositories of personal data that may interface with health information, issues around consistency of definitions (data quality and reliability), data privacy, data linkage and the format in which data is captured and stored, have, in themselves, become specialist fields. (Bowman, 2013.)

Possibly, the one area that remains entirely within the control of a health care professional is data quality within the source document, which often is the patient's medical record. The quality of this data is ensured by standardisation.

Standardisation is a term that basically means the sector has established rules or guidelines that characterise what information to collect and how that information is used. Hospital privacy laws apply to this data as they do to traditional paper data. It is important to note that in some countries, data privacy laws are also in place.

Capturing health information and data applies to the defining, recording, analysis and display of clinical data and information, and it relies on the development and evaluation of information assets, forms and tools.

International efforts related to standardisation of coding health and disease include the utilisation of the World Health Organization (WHO) International Classification of Diseases (ICD) Version:2015; SNOMED CT from the International Health Terminology Standards Development Organization; and the International Cooperation of Primary Care (ICPC) code from the World Organization of National Colleges, Academies and Academic Associations of General Practitioners/Family Physicians (WONCA). Alongside these, there is the standardisation of definitions and processes within health information systems, including CENTC251 in Europe, HL7 in USA, the Healthcare Task Force of the Object Management Group, and

OpenEHR. (Benson & SpingerLink, 2012) It is important to find out which classification systems are available and used, in each facility, in order to ensure that the data recorded is compatible (transferable) across the system/s and facilities.

Maintaining high quality and complete patient records is a challenge, significantly, but not entirely due to competing demands on a clinician's time. (Goetz et al, 2012; Li et al, 2003; Campbell et al 2001.) The complexities of health information systems adds to existing barriers of capturing and sharing clinical information. (Van Der Meijden, 2003; Police et al, 2010.) Structured, systematic and complete documentation of specific clinical data has however been demonstrated to occur when mandated by ICH-GCP or similar guidelines for information gathered as a part of clinical research. (El Fadly et al, 2011.) It is essential also that high quality information be routinely documented because in many countries, medical records are a legal document admissible as evidence in a court of law.

For further information

- International Health Terminology Standards Development Organisation. <http://www.ihtsdo.org/>
- Primary Health Care Classification Consortium. http://www.ph3c.org/4daction/w3_CatVisu/en/icpc.html?wCatIDAdmin=1106
- Westra, B, L, Delaney, C, W, Konicek., & D, Keenan, G. Nursing standards to support the electronic health record. *Nurse Outlook*. Sep-Oct 2008; 56(5):258-266.e1.
- World Health Organization. ICD-10 Version:2015 <http://apps.who.int/classifications/icd10/browse/2015/en>
- World Health Organization. Universal eye health: a global action plan 2014–2019. 2013. <http://www.who.int/blindness/actionplan/en/>

References

1. Benson, T., & SpringerLink (Online service). Principles of health interoperability HL7 and SNOMED (2nd ed.). 2012. London. New York: Springer.
2. Bowman, S. Impact of electronic health record systems on information integrity: quality and safety implications. *Perspect Health Information. Management.* Oct 2010; 1;10:1c. eCollection.
3. Campbell, S, E, Campbell, M, K, Grimshaw, J, M, & Walker, A, E. A systematic review of discharge coding accuracy. *Journal of Public Health Medicine.* Sep; 232001;(3): 205-11.
4. El Fadly A, Rance B, Lucas N, Mead, C, Chatellier, G, Lastic, P, Y, Jaulent, M, C, & Daniel, C. 2011. Integrating clinical research with the Healthcare Enterprise: from the RE-USE project to the EHR4CR platform. *J Biomed Inform.* Dec; 44 Suppl 1:S94-102.
5. Gibbs, G. *Learning by Doing: A guide to teaching and learning methods.* Further Education Unit, Oxford Brookes University, Oxford. 1988.
6. Goetz Goldberg, D, Kuzel, A, J, Feng, L, B, DeShazo, J, P, & Love, L, E. EHRs in primary care practices: benefits, challenges, and successful strategies. *Am J Manag Care.* Feb 1 2012;18(2):e48-54.
7. Gummadi, S, Housri, N, Zimmers, T, A., & Koniaris, L, G. Electronic medical record: a balancing act of patient safety, privacy and health care delivery. *Am J Med Sci.* Sep 2014; 348(3):238-43.
8. Li, J, Morlet, N, Semmens, J, Gavin, A, & Ng, J (EPSWA Team). Coding accuracy for endophthalmitis diagnosis and cataract procedures in Western Australia. The Endophthalmitis Population Study of Western Australia (EPSWA): second report. *Ophthalmic Epidemiol.* Apr 2003; 10(2):133-45.
9. Limburg, H. Monitoring Cataract Surgical Outcomes: Methods and Tools. *Community Eye Health J.* 2002; 15(44):51-53. <http://www.ncbi.nlm.nih.gov/pmc/articles/PMC1705876/> Accessed 09.06.2016
10. Lopez, M, H, Holve, E, Sarkar, I, N, & Segal, C. Building the informatics infrastructure for comparative effectiveness research (CER): a review of the literature. *Med Care.* Jul 2012; 50 Suppl:S38-48.
11. Machin, H. *Ophthalmic Nursing Volume 1: Getting Started.* 2012. ORBIS International. New York. http://www.cybersight.org/bins/content_page.asp?cid=1-13436-13440 Accessed 22nd June 2016.
12. Morrison, Z., Fernando, B., Kalra, D., Cresswell, K., & Sheikh, A. National evaluation of the benefits and risks of greater structuring and coding of the electronic health record: exploratory qualitative investigation. *Journal of the American Medical Informatics Association : JAMIA,* 2014; 21(3), 492–500.
13. Nursing and Midwifery Council. The Standards to support learning and assessment in practice. 2008. <https://www.nmc.org.uk/standards/additional-standards/standards-to-support-learning-and-assessment-in-practice/> Accessed 22nd June 2016.
14. Standards Australia (Paraphrased from). Accessible at <http://www.e-healthstandards.org.au/ABOUTIT014/WhatisHealthInformatics.aspx> Accessed, 19.01.2016.
15. Pisani, E, & AbouZahr, C. Sharing health data: good intentions are not enough. *Bull World Health Organ.* Jun 2010; 88(6):462-6.
16. Police, R, L, Foster, T, & Wong, K, S. Adoption and use of health information technology in physician practice organizations: systematic review. *Inform Prim Care.* 2010; 18(4):245-58.
17. Royal College of nursing Guidance for mentors of nursing students and midwives: AN RCN Toolkit. 2007. <https://www.rcn.org.uk/professional-development/publications/pub-002797> Accessed 22nd June 2016.
18. Shekelle, P, G, Morton, S, C, & Keeler, E, B. Costs and benefits of health information technology. *Evid Rep Technol Assess (Full Rep).* Apr 2006; (132):1-71.
19. Vaughan, P. The importance of reflection with improving care and improving standards and the 6 C's. 2013. The Royal College of Nursing. <http://www.termolitas.net/book-trend/vaughan-p-2009-the-importance-of-reflection-with-improving-care-and-improving-standards-and-the-6c-s.pdf> Accessed 22nd June 2016.
20. Van Der Meijden, M, J, Tange, H, J, Troost, J, Hasman, A. Determinants of success of inpatient clinical information systems: a literature review. *J Am Med Inform Assoc.* May-Jun 2013; 10(3):235-43.
21. World Health Organization. Emergency and essential surgical care Publications home page. 2016. <http://www.who.int/surgery/publications/en/> Accessed 09.06.2016.

SECTION 10

Outreach and Working with Teams, Volunteers and Non-Government Organisations.

Contributors: Heather Machin and R.Meenakshi Sundaram



Throughout this text, the processes required when managing and working within a fixed conventional healthcare facility have been discussed. This section will explore how health professionals can use their skills and knowledge to service rural and remote communities. These services are often referred to as outreach visits. The section will examine specific needs of outreach practice and how principles covered in prior sections can be applied to the outreach environment. The role and responsibilities of visiting national and international development and healthcare professionals will also be discussed.

Outreach

The definition (or objective) of an outreach programme is based on the principle of reaching out to those in need and providing them with help, making use of local resources and providing services to areas which may or may not have regular access to services. In the ophthalmic context, this means reaching out to patients and hospital colleagues, with equipment, supplies and support, and assist with the provision of essential eye care services to their community. Sometimes these programmes can be long term but mostly they are for a set period of time (i.e. 2 week visit every year). While these may not assist in service and long term sustainability (if done without a long term plan) they do help reduce backlogs, waitlists and provide relief to local people who would otherwise wait longer for treatment. Outreach programmes also help organisations to achieve their mission of ‘Eliminating Needless Blindness’ in terms of reaching the un-reached communities and helping them to utilise the available resources.

These programmes are designed to provide services to patients as close as possible to where they live, reducing long distance travel to attend a city-based facility - at great social and financial cost to themselves. The key success of outreach is that it provides the service at the ‘door step’ of those in need.

The need for eye care services amongst poor people, especially women and the elderly, remain high in many parts of the world due to a lack of awareness, access and affordability. Therefore, outreach programmes not only provide access to eye care, but also address socio- and economic barriers which prevent these groups of patients from accessing services. It is also an opportunity to educate the community on eye care and address conditions such as cataract, refractive error and diabetic eye disease.

Outreach programmes are sometimes called “camps” a term which refers to a group of visiting professionals, their equipment and stock and the services they provide. It often looking like a camp-site. These days, camps are less and less common as permanent services are established, though they are still useful in hard-to-reach areas. Outreach visits need to be planned, to respond to the needs of the local area, and may have a particular focus, e.g. identification of cataract cases, or optometry and provision of spectacles.

This section will examine the outreach approach through the example of the Team at Arvind Eye Hospital in India. It will explore their application of functional and safe working systems within the remote (mobile) environment.

Eye screening

Arvind has been conducting eye screening visits, across its service area, since its inception. It caters for close to 60 million people in the province of Tamil Nadu – in the southern part of India. Outreach is considered a central part of the wider regional commitment to eye care. Their medical team consists of medical officers, nurses, technicians (sometimes referred to as mid-level ophthalmic personnel) and coordinators who establish a base in a particular village, and screen a number of people for various eye problems. All their eye screening visits are conducted to raise awareness within the community, engage local well-wishers and other service organisations, and promote eye health.

During these visits, the Arvind Team often identifies patients who can be easily treated immediately, others who require further medical treatment and investigation, and finally, those who need surgery.

Vision centres

Arvind also sets up vision centres which are permanent, primary eye care facilities designed to cater for populations of around 50,000.

Awareness campaigns

While treatment and services to patients, who present for examination, is essential, a significant aspect of the visit is to help prevent blindness in the future and help to reduce visual, health and lifestyle burdens from progressing to the next stage of disease advancement. Therefore, Awareness Campaigns remain a central part of the approach.

Different programmes require different activities but, in essence, awareness campaigns are designed to educate the community about prevention, signs of disease, and when/where to seek help. For example, the Arvind team may organise public lectures on eye health education, or work with the local media outlets to help spread key messages to the target community audience. Interactive sessions with the public are also arranged via rural workers, volunteers and school teachers. Larger awareness rallies are also an approach that can be utilised on special occasions like World Sight Day, and Eye Donation Fortnight etc. to bring wider attention to eye care.

7 Strategies for Effective Outreach Programmes

Arvind has learned through experience that there are 7 strategic areas which have effectively and efficiently strengthened their outreach programmes. These are sustainable and are transferable to other lower resource settings (Figure 10.1).

1. Needs analysis
2. Planning outreach
3. Human Resources
4. Community engagement
5. Standard protocols
6. Finance management
7. Monitoring and evaluation



Outreach Programmes

Needs analysis

A needs analysis requires the collection of data to help understand the needs of a specific area or population group (demographics). With this information, healthcare teams can determine where the gaps are in service and put in place a plan to remove the gaps and make long term improvement in services.

Needs analysis checks can investigate a variety of issues – which really depend on the relevance to the population and to those asking the questions. For example, a community leader may report that their people need eye care services. In order for the medical team to know how and who to help, they have to understand what the needs of the specific community really are. This will assist them in making sure they bring along the correct equipment and specialist team members, and design an appropriate programme.

Table 10.1 is an example of an Analysis Form used by Aravind. In this example, Aravind seeks to understand the magnitude of blindness in relation to age-related factors. They can use this form in several of their outreach visits to understand the prevalence within that population group. Additionally, by using the same form in all locations, they can compare one group to another. This helps them to determine the degree of need.

Analysis of Age Profile & Magnitude of Blindness as part of Outreach Planning			
Age Profile and Predicted Magnitude of Blindness		%	Dindigul(TOWN) 21,61,367
Age Group	0-4	8%	1,72,909
	5-14	19%	4,10,660
	15-39	44%	9,51,001
	40-44	6%	1,29,682
	45 and above	23%	4,97,114
Ci	Cataract to be done in a year (10,000 CSR)	1%	21,614
GL	Glaucoma	1%	21,614
	Blind due to Glaucoma	10%	2,161
D.R.	Diabetic pts in 40+ population	10%	62,680
	Diabetic Retinopathy	20%	12,536
REFEROR	0-4	0%	0
	5-14	5%	20,539
	15-44	8%	86,455
	45 and above	90%	4,47,403
	CHB	Pediatrics is approximately Childhood Blindness problems	8% 0.08%

Table 10.1: Prevalence and patient profile

Table 10.1 helps Aravind to determine the prevalence of specific conditions and diseases to both the entire community and the age group sub-categories. Please see section 9 of this text for further details on how to capture and use data.

Planning outreach

Planning is central to everything and needs to take place well in advance of any outreach visit.

Aravind commences outreach planning at the beginning of every year, and does so by involving all the outreach staff members – which includes medical, nursing, technician and programme team members. The team leader will provide guidance, and support them to collect the base information needed to put in place effective programmes for the next year. They also check that their plans relate to goals outlined by groups such as the International Agency for the Prevention of Blindness (IAPB) and/or other groups such as the Ophthalmology or Nursing Councils. The target setting process involves;

Reviewing their outreach performance over the past few years (i.e. 3 – 10 years)

- What went well?
- What did not go well – how can this be avoided in the future?
- What aspects of their wider plans (i.e. IAPB or national

targets) have changed and what do we need to do to meet those targets?

- What local issues do they need to be aware of based on their last visit.
- What professional standards have changed and how can they ensure their team are meeting professional expectations and promoting key standards (i.e. what are national and international ophthalmology and nursing practice expectations of professionals)?

Determining their targets for the next period

- What service and professional standards do they want to meet?
- Do they need to continue visiting one town or should they cease and instead work in other areas?
- What are the IAPB and national targets – can these be met?
- What is the budget?
- What are the strengths (core competencies) of the medical and professional team?
 - can the programmes cater to these strengths or do experts need to be recruited?
- Can this programme be carried out alone, or can it be operated in partnership with other groups (i.e. local healthcare workers or the ministry)?

Productivity in terms of visits (i.e. larger teams may perform 50 cataracts a day while smaller teams may aim for 20-30)

- Scheduling – number of days, hours of work.
- Checking for clashes with: other visitors, public holidays, public events, civil unrest/conflicts or emergencies (i.e. a recent earthquake may impact on a community's ability to host a team, and a patient's ability to travel. In addition, there might be more pressing issues facing the community which take priority).
- Checking that the organisation hosting the outreach visit (e.g. person responsible for the clinic, community leader) agrees to the date and informs local people so that they present on the day.
- Space – Confirming where the team will work (i.e. 1 or 2 operating theatres) and how can the space can be used effectively without compromising regular service at the facility.

Surgery services

- What sub-specialties will be the focus during each visit? This will help streamline operational aspects of the planning – i.e. bulk stock purchasing and control and specialist rostering.
- What will the team aim for (i.e. Cataract Surgery Rate)?
- Is an agreement (Memorandum of Understanding/Terms of Reference) in place?
- What is the target commitment (i.e. in simple terms – market share of the service)?
- What are the long and short term commitments and responsibilities (ethics) i.e. how will patients be followed up after the visiting team leaves?

Available resources like HR and Infrastructure, such as:

1. Their staff or our staff – how will this work?
2. Their stock or our stock – what do we need to bring? Is storage space available, i.e. fridge or locked room etc.?
3. Their machines or our machines? What do we need to bring? Safe transport containers and conditions for our machines?

Human Resources (HR)

People are the most important part of any plan and dedicated time and effort needs to be given to Human Resources (HR) – such as the care and management of those in the organisation. As discussed in sections 1 and 9, it is important to take care of staff and each other. This is especially important when teams are working away from a main central base. This can be achieved by providing them with a safe, supportive and caring environment on the ground. The team in head office must be competent in supporting the needs of field-workers and the requirements of professionals who need to maintain their professional status/license.

Outreach teams, depending on their size and complexity, comprise of; a general coordinator/manager, administrator, medical, optometric and nursing leader, and an onsite-visit organiser. This team works together collectively and each brings valuable knowledge and expertise to the programme. Their involvement will impact on the success of the programmes long term.

This team, generally, will find one or two local representatives, in each location, who they will liaise with for logistics and organisational planning, scheduling, public promotions and patient selections, stock management, hotel bookings, and billing and agreements.

When the visit begins, and depending on the agreement, the visiting team works with the existing local staff to provide the services that were agreed upon. Indirectly, this is a unique and rewarding experience for those involved, as it is an opportunity to learn from each other, share experiences and embrace new opportunities in practice, development and professional networks.

For more information on Human Resources, please see section 9.

Community engagement

In order to understand a community's needs, Aravind starts by identifying a dedicated community partner (i.e. hospitals, companies, businesses, universities or religious and special interest groups) to collaborate with. The partnership could be for sponsorship (funding), or service provision or promotion. Sometimes, multiple partnerships are established to support various aspects of a programme. They will work with these partners to conduct the planning visit/s, the actual "camps" and all follow-up visits and transfers of agreed documents or statistics.

By engaging with, and working with partners, Aravind is able to spread key messages about eye care to the community and ensure that as many people as possible can benefit from the opportunity as possible.

The benefits of community engagement in outreach lead to:

- Collaborative ownership, pride in the programme and shared success.
- Acceptance in the community:
 - through connecting with reputable and influential organisations/community leaders.
- Supporting facilities/each other to develop the services locally.
- Standardisation (uniformity) in both service provision (treatment) and the compliance of patients – which not only ensure equal and equitable access to the safe level of care, but also ensure measurability across sites.
- Prevention of/co-management of critical events (crisis management/risk mitigation).
- Increase the opportunity to promote the visit:
 - increase potentiality of new walk-in patients.
- sustainability of the programme:

- ensures local representation after the visit
- opportunity to reiterate and provide repetitive eye health messaging.

Policies and procedures

As discussed in section 9, standards, policies and protocols (sometimes called Work Instructions, Standard Operating Procedures or an SOP) are essential to healthcare and ensure that safe, uniform and equitable care is provided to all patients.

Many of the items developed and utilised for fixed hospitals and day-stay (day surgery) facilities can be applied to the outreach situation. However variations in procedures in each outreach visit and agreed levels of acceptable and non-acceptable service, need to be determined so all team members are aware of the changes, and can adapt their practice collectively.

The largest variation that needs to be accepted is that outreach teams are working in other facilities – often with limited resources and generally with lesser ability to maintain standards or control of the environment. Therefore, the clinical team (ophthalmologists, nurses and optometric staff) need to determine appropriate best practice. These need to be worked into agreed policies prior to the visit.

It is also a good idea to integrate into any agreements (Memorandum of Understanding), in advance, the professional standards and expectations of the visiting team – otherwise, this can cause friction to the clinicians on the ground, during the visit, as the two different systems may clash. Although the difference in standards (e.g. protocols for surgery) may be surprising to the host team, it is nonetheless an opportunity for discussion and exchange of knowledge.

Standards adapted from the fixed facility to the outreach environment may also need additional inclusions regarding pre-, post- and follow-up visits. This may include non-clinical processes too. Again, it is a good idea to reach agreement of these, prior to the signing of any agreement.

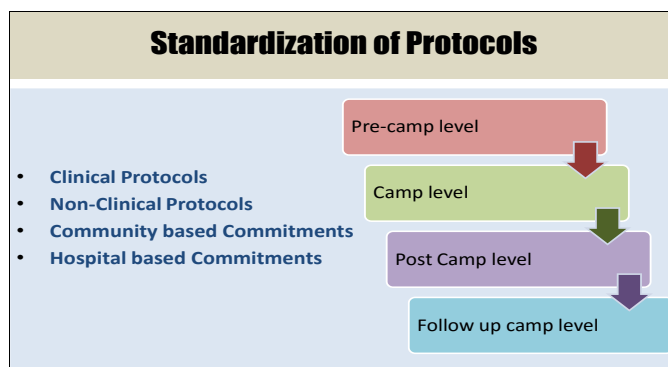

Figure 10.2: Standards and Protocols

Outreach standards and policies need to be reviewed and signed by the fixed (home base) facility Director of Nursing and the Medical Director, just like any other policy. This is to ensure that the outreach practice is fundamentally inline with their hospital's wider expectations of professional practice and/or the national and international expectations of their respective professional bodies, albeit adapted to the mobile environment (Figure 10.2).

Outreach screening - visit management

The "screening" aspect of the visit is conducted preferably in established buildings – i.e. clinics or school buildings, because of their size, familiarity and accessibility to the community. Any scheduled surgery needs to take place in an established OT.

Organising and logistics

The Team need to arrive in advance of any start date to ensure the anticipated patient attendance rate will be met and that the space is ready to use. They need to factor in time to review the “space” and work out where to set up machines, waiting areas, access points and to ensure smooth processes and a reduction in bottlenecks at entry and exit points.

The entry areas need to be established with registration tables, signage and waiting line demarcation points and/or chairs.

Arrangement of the space also needs to consider persons with vision impairment and other disabilities – i.e. steps, glass panelling, hazards etc. and systems/implementation methods required to prevent injury or confusion.

Prior to opening the doors on the first day, the team needs to re-group to ensure everyone knows their job. They are each responsible for checking they have all the space and equipment they need to meet the expected demand. While the clinical team’s work is very important, special attention also needs to be given to the non-clinical aspects, such as crowd control, security (to prevent theft), helpers to assist the vision impaired, lunch break routines, troubleshooting and general administrative duties, such as filing and data tracking once the patient leaves the space.

The clinical screening teams need to be aware of several key assessment points. The team must ensure that the most appropriately trained (competent/licensed) person is assigned to oversee each task – i.e. final examinations in many countries are the role of the physician. This is outlined further below:

- **Preliminary vision test** - Includes measurement of the visual acuity in a distance of 6 metres via a Snellen chart (consideration is needed for age, language and literacy).
- **Preliminary examination** - This is an initial case history recording – almost like a triage process, whereby the patient’s presenting complaints and medical history are recorded. The team then uses this information to refer the patient to the next/most appropriate specialist/test, i.e.
 - **Intraocular Pressure (IOP) measurement** - In this step, IOP is measured (i.e. by using Schiottz or Perkins tonometer or i-care tonometer) and recorded.
 - **Lacrimal syringing** - This is sometimes needed for people aged 40+ to ensure the lacrimal passage is clear without any block
 - **Refraction** - This is routinely checked. Patients with refractive error can receive a prescription and/or a pair of glasses, prior to leaving (depending on the system and agreement).
 - **Final examination** - Patients may need to be referred to a physician if local nurses are not trained or approved to perform final examinations. In this examination, for example, most of the common eye problems and some posterior segment problems will need to be examined and confirmed (diagnosed) in order for a treatment plan to be presented to the patient. This may include medication, education, surgery, spectacles, further diagnosis in specialty clinics or referral onwards (i.e. to a diabetic educator).

Additional services:

Many outreach screening areas will provide additional services, such as:

- **Counselling** - Counsellors are used to help explain the nature of problems, appropriate treatment/surgery and the

consequences to the patient if they decide not to follow the recommended treatment plan – this is an important aspect of the informed consent process. Please refer back to section 4a regarding the process of informed consent.

- Note: technical aspects can be performed by specialty trained nurses or junior doctors, however, non-technical staff/volunteers can assist.
- **Pre-surgery scheduling** - Should a patient be identified as requiring surgery, separate teams may be established (depending on the size of the team) to provide pre-operative information to the patient and complete an informed consent check.
- **Optical services** - These services can be offered to allow patients to pick up their frames and lenses on the day. It also prevents patients from having to journey back to the town/city on another day to collect their frames. Specialist ophthalmic/optometric staff and technicians can liaise with optical sales persons to offer this service. The team often arrives with a pre-set amount of suggested lenses of various power and strengths.
- **Surgery patients** - Depending on the agreement with the partner organisations, and the size of the visiting team, patients may be scheduled for surgery. This can take place on the same day or on a pre-arranged date. To do this, the team need to decide, prior to the screening day, if they can offer this service. They also need to know where the surgery will take place, i.e. locally or in the city. This must be conveyed to the patients so they can make plans to be at the location.

If the surgery is taking place in the local hospital, the clinical and OT members of the outreach team need to tour the facility and ensure it is suitable (taking into account local standards) to provide the intended surgeries. If not, discussions, agreements and plans need to take place between the clinical teams to ensure the facility is adequately equipped.

Again, depending on the agreement, the team may need to negotiate for overnight stay options for the patients so they can be reviewed post-operatively. While this is not medically required, this is often recommended for rural and remote patients who would otherwise be without accommodation locally.

Follow-up

Visits are conducted for those patients who undergo surgery.

The dates for these will vary depending on the surgery (i.e. intraoperative or plastics) and if the patient experienced complications, infections and/or other issues or surgical requirements that need review or referral. In general however, these are at the following intervals:

- day 1
- around 4 weeks
- long term: i.e. if routine surgery, the physician may ask the patient to return in 6 or 12 months
- during the follow-up visit, a physician and refractionist examine the patient, and follow-up care and treatment will be evaluated based on those findings.

Note: it is important that a local clinician is available to provide long term post-operative care. This should be determined during the planning phase.

Table 10.2 outlines the list of Items that are required for clinical set up in outreach:

Free Eye Screening Camp					
Camp site requirement on Space, Furniture, Volunteers and other Supplies for the expected number of 300					
STEPS	Space	Furniture	Vol.	Clinical Manpower	Clinical/Non clinical supplies
1. Registration	Space at the entrance of the school	2 Tables and 3 chairs	3	Camp Organizer (will guide the volunteers for proper registration of patient particulars)	OP register, OP Card and ID Card
2. Preliminary Vision test	A room with 20 x 15' space	2 long benches	1	1 Junior Paramedical Staff	Snellen charts
3. Preliminary checkup by Doctor	A room with 10 x 15' space with more waiting area	2 Tables, 2 Arm Chairs and 4 foldable chairs (& few benches for waiting)	1	1 Jr. Medical Officer/PG Student for Preliminary and 1 Sr. Medical Officer for final examination	Torch light, Direct Ophthalmoscope, Some samples of Antibiotic and Steroid drops, ointments, Table cloth, A basin and dextol, soap, Bell pins, Continuation card, Drug pad and Glass pad
4. IOP and Duct test	A mini hall with 15 x 15' space with waiting area	2 benches and 2 folding chairs	1	1 Senior Paramedical Staff	Tonometer, Wiper, Saline water, Local drops, Syringe, Needles, a match box, lamp and dialating drops
5. Refraction	A room with 20 feet distance with enough space for dialation	6 folding chairs and 5 benches for waiting	2	1 Senior and 1 Junior Refractionist	Pow er extension boxes, Cubicle with cloth, Trial set, Bulbs and Streak retinoscope
6. Final examination by the Doctor	Preliminary and Final can put together	Preliminary and Final can put together		(Ref. Step 3)	(Ref. Step 3)
7. B.P. Recording & Blood Sugar test	A room with 10 x 8' space with waiting area	1 Table and 2 chairs	1	1 Senior Paramedical Staff	BP apparatus, Needle, Spirit, Sugar test Strips, Sterile cotton pads, Glucometer
8. Counseling and Admission	An area with 10 x 10' space with more waiting area	2 Tables and 3 chairs (& few benches for waiting)	2	1 Patient Counselor and 1 Camp Organizer (volunteers can help the organizer to transport the patients to the hospital)	Model IOL, Awareness charts, posters, Referral cards for systemic problem and specialty cases, IP register, IP card, Discharge summary, Consent form, counseling stamp and stamp pad
9. Spectacles dispensing service	A room with 20 x 15' space	3 Tables, 2 chairs and 6 benches	1	1 Sales person and 1 Optical technician	Frames, lens, sivet cloth, Optical case, Table Mirror, Reading Chart, Bill book, Order book, Spectacle pouch, Display tray, Optical ruler, Edging equipment, Frame w armer, Portable generator, Chipper, Frame adjustment pliers, Diamond cutter, Glass marking pencil, Axis marking chart, Trial set and Water can

Table 10.2: Outreach screening – visit management

Financial management

All outreach programmes need to be conducted within the set budget. How or who funds different aspects of a visit depends on the agreements and partnership with the local organisations. This also extends to determining if patients are expected to pay for any or all of the services. For example, some teams may negotiate and agree that the visiting team will fund all the staff and surgeries and post-surgical related complications, the local facility will fund all the electrical, food and water needs, and the patient is required to pay for glasses/frames and medications, such as eye drops.

There are many different ways to fund the visit and share the expenses. Therefore, it is best to ensure the organisation's accountant is involved and available to assist and train staff on programme budgeting.

Monitoring and evaluation

Monitoring and Evaluation (M&E) offers a way to determine whether the programme has been worthwhile in terms of delivering what was intended and within budget. Good evaluation can also answer other important questions and helps understand outcomes, success rates and areas of need.

Aravind has developed a strong monitoring system to measure the results. For instance; each outreach visit performance is measured based on the following parameters (Figure 10.3):

- Number of outpatients registered against prediction (not less than 90% of expectation).
- How many patients in 40+ age group (75% of OP).
- Number of cataract patients registered against prediction (not less than 90% of expectation or 20% of patients).
- Cataract surgery acceptance rate (85 to 90% of advised patients).
- Number of persons who received glasses prescriptions (15 to 20% of OP).
- Spectacles acceptance rate (70 to 80% of advised patients – because they need to pay).
- Overall defect rate.
- How much has been spent to get one cataract patient registered for surgery (Rs.250/-).

M&E can also include clinical quality management activities/items, as outlined in section 9, i.e. clinical indicators and clinical audits. This needs to be determined during the planning phase.

For further information

- Section 9 - Data Monitoring and Evaluation in the OT context
- Community Eye Health Journal - General information on RAAB) <http://www.cehjournal.org/resources/raab/>
- Rapid Assessment of Avoidable Blindness (RAAB) Repository <http://www.raabdata.info/>

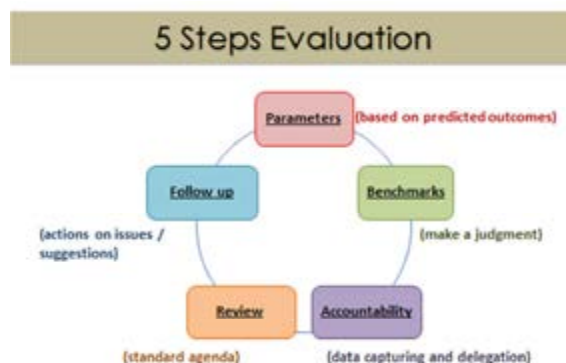

Figure 10.3: 5 steps Evaluation

Packaging and Transfer of Stock

Section 9 discussed the management of stock (supplies). Such management also applies to outreach visits. The difference with outreach will be the need to document stock and equipment leaving the facility and documenting it again once it has been returned. This will help ensure a cost can be allotted to the outreach visit and stock levels can be monitored and maintained.

If stock systems (i.e. practices of stock going back-and-forth between locations) becomes too complicated, outreach teams can order and store their supplies separately to the main hospital supply.

Please see section 9 for further information on stock (supply chain management).

Working with Teams, Volunteers and Non-Government Organisations (NGO)

One of the joys of working in eye care and undertaking outreach visits is the opportunity to work with visiting clinical teams (paid and volunteer) from overseas and from other cities around the country. It is a wonderful opportunity to learn about other cultures, different professional approaches, new clinical techniques, and most importantly, it is a great way to network and meet fellow colleagues – many of whom will become life-long friends.



Photo 10.1: Dr Gabriella Ruiz Gonzalez of Mexico, experiencing the culture and food in Surabaya, Indonesia with Dr Delfitri Lutfi on a day off.



Photo 10.2: RN Heather Machin experiencing Pacific Island hospitality and ceremony with RNs Tima Nukusere Seru and Viniana Tagi in Fiji.

While there are many benefits of working with visiting teams, there are several key steps that need to be considered and factored into the planning. These are important points to be mindful of.

Preparations and working with visiting (and international) teams:

- Prior to introducing an international team/clinical person into the hospital, always check that they have authority to do so from the hospital management's key contact person.
- Check that they have been professionally licensed (profession specific) to work in country, prior to allowing them to interact with a patient. They will need to show their license to the hospital manager/contact person. If they do not have this, then they are not permitted by law to perform patient care (however, they may be eligible to do classroom education and non-licensed community eye health work such as crowd control or guiding patients – check the local laws).
- They may work differently, move furniture/equipment, use the space differently, bring their own equipment and patient chart templates, act differently and perform their duties differently. This can be overwhelming but it can also be exciting and a great opportunity because often “a fresh pair of eyes” can help to maximise the space, resources and equipment. Instead of worrying about the strange things they are doing, use the time to observe them, ask them questions and try things their way – this is a great (and free) opportunity to see if there are any new skills and ideas that can be retained, once they have left.
- They may interact between each other differently. For example nurses in many countries are highly respected and equal members of the executive management team and board. Additionally, clinicians from some countries may not use titles. It is common once they meet a new person that they will insist on being called by their first name (though not always in front of a patient). If they offer this, please comply.
- They may have travelled a great distance so they may be tired. Allow them some space to rest and sleep and be mindful that sometimes jet lag and changes in sleep and diet may make them more irritable than they would normally be. Therefore, allow them a chance to settle in and learn about the country, hospital and system before passing judgement.
- They may have a different language, religion, diet and lifestyle. This is a wonderful opportunity to learn about other cultures.
- They may become sick quicker because their bodies may not be used to the food, water and general environment. This might make them less comfortable than they would normally be.
- They may advocate for the use of more single-use-only items. If their budget is paying for it, allow them to use single-use from their own stock if they wish to.
- Depending on the size of the programme, budget and origin

of the team, an international team may generate more waste (rubbish) and/or used linen. This primarily relates to the trend in their countries of single-use only. Waste and linen management will need to be discussed during the programme planning phase.

- They may need to keep a record of care for their own organisation too. Therefore issues might be complicated between two lots of paperwork. Work together to find out how both systems can be complemented.
- Like all new people, they may not know where everything is in the hospital. Additionally, they may not know the city/town or language, and they may have had to alter their routines. These can be frustrating to them and some may feel isolated. Therefore, please help welcome them, and offer to orientate them as much as you can. This will increase their joy of visiting the country and will make them less stressed. It will lead to greater friendships and opportunities for future interactions.
- Some groups have mobile hospitals (i.e. boat, train, truck or plane. Photos 10.3 - 10.6). These are great learning opportunities as they bring a ‘different way of working’ right to the doorstep. They also require a greater degree of pre-programme logistics planning and appropriate patient selection – especially if the mobile hospital is some distance from a general hospital/intensive care unit.
- Some visitors may like to take photos of patients, staff and the facility. Make sure that privacy laws are followed and that permissions from the hospital, patients or staff are obtained. Also, check to ensure the photos will be used in the professional capacity only (i.e. not uploaded to Facebook without appropriate permissions obtained). This might be something that can be discussed in the planning phase.

What to expect of them

Note: these key points should all be checked prior to the arrival of any visitors. The evidence and documentation are generally provided to one key contact for confidentiality reasons.

- Clinical team members are both licensed and competent in what they are doing and/or teaching. This means that they need to demonstrate evidence of recent practice or training in their own countries.
- They are not “testing” and “learning” on local patients. They need to demonstrate that they are trained to perform that technique prior to doing so. If they are not trained or allowed to perform something in their home countries, they should not be performing it in someone else's.
- They are not performing surgeries considered illegal or engaging in criminal acts.
- They are giving/donating items that are in date. The WHO does not advocate for expired items to be donated. Therefore, do not accept expired donations.
 - if offered donated items that are not needed, always decline to accept them even if, culturally, it would be rude to reject the offer. They will not take offence. This is important because there is no point accepting something that will stay in a storeroom and never get used. If not needed then please say so. That way the items can be offered to other hospitals that will use them
 - with regards to equipment. If they cannot be maintained long term (i.e. maintenance and accessory items) then again, do not accept the offer.

Hours of service

To a visitor, the opportunity to work in another town or country is a once in a life time opportunity – and it may have cost them a great

deal of money to do so. For this reason, many visitors want to work very long days, i.e. 10+ hours with very few breaks, so they can get as many patient cases done as possible, and maximize their visit.

This allows them to return home and announce to their sponsors how many cases were performed, and in turn generate more funding to help more patients. As they often come from countries with high-volume turn around, they often seek to match the same output. Their intentions are admirable and a great deal of work is accomplished during their visit.

Some visitors however, may not realise that locals still have their own work duties to attend to, and their own commitments outside of work. They may not realise that, while working a long week is a once-off-event for them, that locals might have to do this again and again for multiple visitors throughout the year.

Agreement on the length of the working day – and breaks, need to be determined at the planning phase. Locals need to factor in if they have other visiting teams at the same time or in the following weeks. If long days are agreed, local staffing levels need to be budgeted and planned to ensure safe staffing levels and adequate break times.

Note: learning how to cater for high-volume patient turn-arounds is a valuable component of the visit and something to strive towards. If long hours and long lists are agreed, use this as a learning opportunity – without compromising quality patient care.

Practice and learning styles

Visitors from different organisations/countries can have different practice styles. This can cause a great deal of confusion when a visitor from one country educates and performs duties in one way, and then another visitor – from another country – does the complete opposite. This can lead to system and one-on-one issues for all those involved. This can be overcome by:

Informing the visitors – at the planning phase:

- Of other organisations they are working with. This will help the visitors to understand why locals may be practicing in a certain manner.
- What they are learning or working on with the other organisation. This will prevent double-up.
- What their learning objectives are, i.e. learning to scrub or take a blood pressure.

Ask the visitors:

- What country they are from?
- Why they are suggesting something or practicing in a certain way?
- How they would do something in their country?
- For copies of their standards/policies or work instructions?

After the visit, reflect on what has been advised, consider how this is similar to what other visitors have advised and integrate recommendations – based on evidence based best practice - into long term practice.

Follow-up re-group

The importance of patient follow-up and data follow-up has already been outlined. A third important follow-up opportunity is that of the team itself. All team members need to evaluate the success and non-success of the visit, to help improve for next time. There are several methods that could be used such as, end-of-visit social reflection time where everyone shares the positive and negatives.

Other options include an anonymous survey (this can also be asked of the locals too) and/or a report whereby a key member of each professional body reports on the outcomes – both good and bad.

While generally talking about the successes and writing reports about all the things that went well is essential, it is important to include the things that did not go so well. A great deal of opportunity is lost in not discussing problems or finding neutral ways to work through them, to prevent them from happening again. Team members should be encouraged and welcomed to share the 'not-so-good' and help work towards improvements. Note: staff should not be penalized, isolated or gossiped about for their honesty and willingness to share the not-so-good.

Depending on the agreements and partnerships, reports may need to be sent to the main hospital, Ministry of Health Representative, WHO or a partnering development agency.

Visit organisational planning

Appendix B provides several examples of tools Aravind use when running an Outreach visit. This includes:

- Camp admission, operation and discharge schedule
- Standard supplies for the camps
- Post camp report



Photo 10.3: YWAM Medical Ship (Hospital) – Papua New Guinea



Photo 10.4 & 10.5: Mobile Eye Clinic (and OT) – Pacific Eye Institute Fiji– Fred Hollows Foundation - NZ



Photo 10.6: Flying Eye Hospital – ORBIS International

Appendix A

Abbreviations, Common Sounding Names, Glossary and Units.



This section includes abbreviations, common sounding names/words, a glossary and a unit table.

Abbreviations

Containing letters and numbers

- C3F8 – Octafluoropropane
- CO₂ – Carbon Dioxide
- N₂O - Nitrous Oxide
- O₂ - Oxygen
- SF₆ – Sulphur hexafluoride
- 5FU – Fluorouracil

Letters only

- AC – Anterior Chamber
- ACLS – Advanced Cardiac Life Support
- ASA – American Society of Anesthesiologists. Used in association with the ASA rating system
- BD – Twice a day
- BLTR - Bilamellar Tarsal Rotation
- BLS – Basic Life Support
- BNX - Oxybuprocaine Hydrochloride eye drops
- BSS – Balanced Salt Solution
- BST – Bacterial Spore Test
- CCC - Capsulotomy or Curvilinear Capsulorhexis
- CEO – Chief Executive Officer
- CJD - Creutzfeldt-Jakob Disease
- CPM – Cuts Per Minute
- CPR - Cardio Pulmonary Resuscitation
- CT - Computed Tomography
- DCR - Dacryocystorhinostomy
- DMEK - Descemet's Membrane Endothelial Keratoplasty
- DON – Director of Nursing
- DSEK - Descemet's Stripping Endothelial Keratoplasty
- ECCE – Extra Capsular Cataract Extraction
- ECG/EKG - Electrocardiogram
- EHR – Electronic Health Records
- EMR – Electronic Medical Records
- ESU – Electro Surgical Unit
- EUA – Examination under Anaesthetics
- GA – General Anaesthetic
- HEPA - High-Efficiency Particulate Arrestance Filter
- HH – Hand Hygiene
- HR – Human Resources
- I/A – Irrigation and Aspiration
- ICCE – Intra Capsular Cataract Extraction
- ICD – International Classification of Disease
- ICG - Indocyanine Green Dye
- INR - International Normalised Ratio
- IOL – Intraocular Lens
- IOP – Intraocular Pressure
- IIV - Intravenous
- VC – Intravenous Cannula
- LASER - Light Amplification by Stimulated Emission of Radiation
- LPO - Local Purchase Order
- LSO – Laser Safety Officer
- M&E – Monitoring and Evaluation

- MD – Medical Director
- MD – Medical Doctor
- MMC - Mitomycin C
- MRI - Medical Resonance Image
- MSD – Material Safety Data
- NBM – Nil-by-Mouth
- NOK – Next-of-Kin
- NSAID - Non-steroidal anti-inflammatory drugs
- OD – Optical Density
- OD - Oculus Dexter (Right Eye)
- OHS - Occupational Health and Safety. Also known as workplace health and safety
- OR – Operating Room (same as OT)
- OS – Ocular Sinister (Left Eye)
- OT – Operating Theatre (Also known as OR – Operating Room)
- OVD - Ophthalmic Viscoelastic Device
- PC – Posterior Chamber
- PD – Pupillary Distance
- PK – Penetrating Keratoplasty
- Phaco - Phacoemulsification
- PMMA - Poly Methyl Methacrylate – a material used to make Rigid IOLs
- PCO - Posterior Capsule Opacification
- PPC - Primary Posterior Capsulorhexis
- PPE – Personal Protective Equipment
- QID – Four times a day
- QM – Quality Management
- SAFE – Surgery, Antibiotics, Facial Cleaning and Environmental Improvements
- SCM – Supply Chain Management
- SICS – Small Incision Cataract Surgery
- SSS – Safe Site Surgery
- TASS – Toxic Anterior Segment Syndrome
- TDS – Three times a day
- TF - Trachoma Follicles
- TT - Trichomatous Trichiasis
- UGH - Uveitis, Glaucoma and Hyphaema syndrome
- VA – Visual Acuity
- VIP – Visually Impaired Person
- VR – Vitreo Retinal
- WPH – Workplace Health and Safety (same as OHS)

Common Interchangeable English Sounding Names/Words

- Allied Health Care Provider – Ophthalmic Allied Health Provider – Mid- Level Professional
- Anaesthetist - Anaesthesiologist
- Day surgery centre – ambulatory surgery centre
- Director of Nursing - Chief Nurse - Charge Nurse – Senior Sister
- Facility – complex – building – centre (i.e. a hospital or day surgery)
- Manager – Supervisor - Department Head - Coordinator
- Medical Advisory Committee - Governance Committee
- Operating Theatre – Operating Room

- Circulating Nurse - Scout Nurse
- Second in Charge (2IC) – Deputy
- Operating Table - Trolley – Bed – Gurney
- Doctor – Physician – Surgeon – Anaesthetist/ Ophthalmologist

Glossary

- Analgesia – Medications used to prevent and/or stop pain.
- Antibiotics – Medications used to prevent and/or stop infection.
- Antiemetics – Medications used to prevent and/or stop nausea and vomiting.
- Antimetabolites – Cytotoxic agent used primarily in glaucoma and pterygium surgery to prevent post-operative scarring and re-growth of tissue by destruction (killing) cells. Personal Protective Equipment and correct waste management principles apply when using these agents.
- Antimicrobial – A solution that reduces the growth of micro-organisms.
- Antimicrobial Stewardship – A strategy used to prevent the over prescription and use of antibiotics in order to ensure the immune system is maintained as best as possible.
- Aphakic – Absence of a Lens.
- Aseptic Technique – Procedures and practices used to prevent the spread (cross-contamination) of micro-organisms.
- Autoclave (Steam Sterilizer) – Machine used to sterilize items via steam.
- Binocular Vision – When two eyes function in unison. Together, their gaze allows for depth perception.
- Biometry – The process of examining the axial length of the eye through specific mathematical analysis. It is measured using an A-scan and is often used for calculating the intraocular lens power required for cataract patients.
- Bleb – Transparent blister or bubble.
- Blood Glucose (Sugar) Test – Assessment of blood glucose level in the body via a device called a Glucometer.
- Blunt – Instruments and/or cannulae which does not have a cutting edge. Therefore they are less traumatic on the tissue.
- Bowie Dick Test – A test used in the sterilization department as one method of ensuring the machine is working. This test is done daily. It is designed to test that the steam has been distributed throughout the chamber evenly.
- Buphthalmos - Literally 'ox-eye'—globe enlargement due to congenital glaucoma.
- Burr – Polishing instrument.
- Calibrate – A process used on machines to ensure that they are functioning, have been set-up correctly and ready for use. Some, like phacoemulsification machines, need calibrating for each patient while glucometers may only need calibrating monthly. Check manufacturing instructions for calibration instructions.
- Cannula(e) – An instrument which has a hole running through it, that is used to perform insertion/injection, aspiration or irrigation of a solution/agent/medication.
- Capsulorhexis – A technique used by surgeons during cataract surgery to open the anterior capsular bag via a 360 degree (circular) tear.
- Capsulotomy – Opening made in the anterior or posterior capsule of the lens.
- Carcinogenic – Potential cancer causing.
- Cardio Pulmonary Resuscitation (CPR) – Attempting to restart the heart.
- Cauterisation – To stop bleeding.
- Cheatle's Forceps – Large forceps used to remove and/or transfer non-wrapped sterile items. They are sterilized and stored in a container of methylated spirits between use. Care should be taken to ensure they are kept in a safe and air controlled area and they are handled within an aseptic manner to prevent cross-contamination.
- Chemosis – Swelling of the conjunctiva - also known as oedema, and non-specific irritation.
- Circulator Nurse – Member of the operating theatre team who does not scrub. The role is primarily to assist the scrubbed members who cannot leave the area. Duties include: documentation; instrument and equipment preparation; assisting scrubbed team and anaesthetic team; liaison with the pre-operative and recovery staff; care of visitors and students to the area; and cleaning and waste removal between cases. Also known as a scout nurse in some countries.
- Congenital – A condition from birth, sometimes carried through the family genetic line.
- Consent Form (Informed) – A formal legal document signed by the patient (or their next of kin/carer), and surgeon and a witness. This is completed once the patient has been informed of the risks, benefits, costs and outcomes expected of the surgery. The form is dated, the procedure and surgical site written on the form and then signed by both parties. A copy is to remain in the patient chart. Ideally, a copy should be provided for the patient to take home too.
- Constrict (constriction) – To make narrower, smaller, i.e. eye drops given to constrict the pupil will make it smaller and the iris bigger.
- Contamination – Introduction (spread) of micro-organisms and foreign matter into/onto sterile material or living tissue.
- Controlled (Dangerous) Drugs – Medications (which in some countries are called Schedule 8) that require restriction of access and use because of the nature of their response on the body, i.e. addiction and/or lethal at unmanaged levels. Morphine and pethidine are examples. There must be a written order from a doctor. Two nurses who are registered to check, prepare and administer this type of drug (and/or with an anaesthetist) must work together to remove the drug from the cupboard, document its use in the drug-log-book and patient chart and be together when the drug is checked and administered to the patient. The drugs must be locked away (preferably behind two locked doors – which cannot be removed) at all times. Only nurses registered to access the drugs may hold the keys. The stock level must be checked no less than twice a day via a cross-reference between the physical count and the record in the log book.
- Corneal decompensation – Destruction of the corneal endothelial cells causing marked swelling of the cornea (corneal oedema) and some loss of transparency.
- Corneal repair – Suturing of the cornea to maintain the anterior chamber, the shape of the cornea and to prevent infection.
- Corrosion – When chemicals gradually eat away at a metal item.
- Cross contamination (infection) – the spread of micro-organisms from one person/item to another.
- Cystotome – Angled needle sometimes used by surgeons to make an opening in the anterior or posterior capsule during cataract surgery.
- Cytotoxic – See Antimetabolites.
- Dacryocystorhinostomy (DCR) – Surgical construction of passage into the nose from nasolacrimal sac to relieve blockage. This can also be done via an endoscopic camera and is known as endoscopic DCR.
- Decontamination - Process of rendering an item free from

- infection, e.g. cleaning a surgical instruments.
- Detergent – Substance used for cleaning - usually dissolved in water.
 - Dilation (dilate) – To make larger, bigger i.e. eye drops given to dilate the pupil will make it bigger and the iris smaller.
 - Dioptre (diopter) – A unit of power used to determine lens power (strength). The calculation result is used when selecting an intraocular lens for a specific patient in order to provide the best possible corrected vision.
 - Disinfectant – Solution used to clean away and destroy pathogenic micro-organisms – but not spores. Personal protective equipment is needed when handling disinfectants. Always follow the manufacturer’s instructions for storage, handling and calculation of concentration. It is also important to check the disinfectant is safe for eye instruments.
 - Double-glove – The practice of wearing two pairs of surgical gloves for extra protection.
 - Drainage angle – Junction of iris and the corneoscleral tissue where aqueous drainage takes place.
 - Dry heat – Air heated to a high temperature by electricity and used at high temperatures for sterilization.
 - Ectomy – This word means ‘remove(al)’ i.e., the word lensectomy means removal of the lens.
 - Ectropion – Outwards turn of the eyelid/s.
 - Endophthalmitis – Inflammation of most of the internal tissues of the eyeball, usually associated with infection.
 - Entropion – Inward turn of the upper or lower eyelid.
 - Enucleation – Surgical removal of intact eye ball.
 - Evisceration – Surgical removal of the ocular content, however the sclera and muscles remain intact.
 - Examination under Anaesthetics (EUA) – The process of using anaesthetics to help keep a patient still (non-moving) so the eye can be examined. This is most often used on children.
 - Expiration (expiry) date – Date before which an item can safely be used, e.g.: sterility or effectiveness of a drug.
 - Extraocular –outside the eye/globe.
 - Extubation – Removal of an artificial airway after reversal of general anaesthetic agents.
 - Eye Bank – A specific facility/department responsible for the ethical recovery, testing, processing and allocation/distribution of donated human tissue for ocular (application) transplantation.
 - Gas bank – The safe placement and storage of gas banks which are connected to outlets in the operating theatres.
 - Germicide – A cleaning solution which can destroy micro-organisms.
 - Glucometer – A device that measures the blood sugar (glucose) level.
 - Familial – Refers to family. When used in the medical sense it refers to a condition/disease that can be traced to other family members (family gene line).
 - Fasting – Process whereby a patient is asked not to eat or drink for a specific period of time. This is often prescribed, in the ophthalmic context, for patients who require a general anaesthetic or a monitored local anaesthetic (sedation) in case they must be reverted to a GA. Different times for food and drink are ordered depending on the age of the patient and the fasting preference of the anaesthetist and/or medical status – i.e. age or diabetes. Always check with the anaesthetist for their specific orders.
 - Fibre Optic – Very fine pieces of fibrous thread which conduct light from the machine to the probe.
 - Flash Sterilizer – Process of quickly sterilizing instruments in a specifically designed machine. Note: This practice is currently not recommended for regular use, with some parts of the world removing the practice all together.
 - Fundus – An internal part of the eye that includes retina and optic disc.
 - General Anaesthetic (GA) – A type of anaesthetic given under supervision to place the patient into a temporary unconscious state in order to perform surgery.
 - Haematoma – Swelling of blood (blood clot) within tissue.
 - Halogen – Gas used in a light to allow a brighter more intense light.
 - Hand Hygiene (5 Stages) – A strategy developed to educate and improve hand hygiene by identifying 5 specific moments of cross-contamination, hand washing and glove wearing.
 - Haptics – “Arms” of an artificial intraocular lens implant. The haptics are dialled/moved into place to anchor the implant into the capsular bag during cataract surgery.
 - Hyphaema – Blood in the anterior chamber.
 - Hypopyon – Yellow or whitish mass (pus) in the anterior chamber. Sometimes infected.
 - Intraocular – Inside the eye/globe.
 - Intubation – A process during general anaesthetic that includes placing an artificial airway tube into the patient (generally the mouth) and introducing agents designed to relax and “put the patient to sleep”.
 - Jinja cotton – 100% cotton with high density weave, suitable for making theatre clothes, gowns, and drapes.
 - Kera – Cornea.
 - Keratome – Knife used to cut the cornea. They are available in a variety of sizes, shapes and angles for a variety of procedures and techniques.
 - Lagophthalmos – Inability to completely close the eyelids.
 - Lamella graft – Removal of superficial layers of the cornea and replacing them with a donor cornea.
 - Lint – Micro-fragments of low-density weave material, increased by repeated hand washing and sterilization.
 - Loupes – Specially designed glasses which contain magnification and are worn by members of the surgical team.
 - Lumen – The interior or hole of instruments.
 - Macro – Large.
 - Micro – Small.
 - Micro-organism – Bacteria, fungi, viruses and spores.
 - Miotics – Drugs which constrict the pupil and increase the outflow of aqueous humour, e.g. pilocarpine.
 - Moist heat - Heat produced by steam at high temperature and under pressure.
 - Monocular vision – When two eyes function separately rather than binocularly. In monocular vision – depth perception is limited.
 - Mucous membrane graft – A membrane (piece of tissue) extracted from the lining of the mouth for transplantation to a grafting site on the upper or lower fornix of the eye.
 - Multi-drug resistant – A bacteria which has become immune to available antibiotics.
 - Muscle relaxant – Drug used during a general anaesthetic to paralyse the muscles in the body.
 - Midriatics – Drugs which dilate the pupil without affecting accommodation, e.g. phenylephrine.
 - Needle stick injury – Injury caused by needles or blades. Needle stick injuries should be reported according to local policy and procedure.
 - Next-of-Kin (NOK) – The person nominated by the patient as being their carer. Usually this is a family member however this varies.
 - Nil-By-Mouth – Please see Fasting.

- Non-Government Organisation (NGO) – An entity or business model that is either independent or an independent part of another entity. An NGO provides a specific service without profiting. Any profit is funnelled directly back into the business rather than to shareholders or governments as other traditional business models do. NGOs can be found in a variety of sectors, i.e. peer professional bodies (e.g. ophthalmic nurses association) or development agencies (e.g. International Agency for the Prevention of Blindness). They are often managed or influenced by their own members. Smaller groups are often managed by volunteers however larger NGO entities will have paid staff in order to provide regular services and project role out.
- Orbital space – Area behind the eyeball.
- Outreach – When a medical and surgical team travel to another location to provide rural and remote communities with care.
- Pallor – Pale appearance of the facial skin.
- Pars plana – A part of the uvea. It starts 1mm from the limbus and extends posteriorly for 6mm. The pars plana is 4mm behind the limbus and has no close relation to the anterior or posterior anatomy of the eye. This makes an ideal site for pars plana vitrectomy surgery incision.
- Patient identifiers – Key information about the patient used to correctly identify them from one another, i.e. name, age or date-of-birth, phone number, address, surgery type and site, name of doctor and allergies.
- Penetrating Keratoplasty (PK) – Removal of a damaged cornea and replacement with a donor cornea.
- Peripheral iridectomy – Surgical removal of a small portion of the iris in the periphery to increase the flow of aqueous from the posterior chamber and into the drainage angle.
- Peritomy – Incision of conjunctiva and cauterisation of scleral and corneal blood vessels.
- pH – Degree of acidity or alkalinity of a fluid.
- Phaco (phako) – Lens.
- Phakic – Has own lens.
- Photophobia – Sensitivity to light.
- Pitting – Small depression in metal caused by rusting or corrosion.
- Probing – Dilatation of the upper and lower puncta including the canaliculi.
- Prone – Positioned face down.
- Prosthesis – A medical device that is permanently implanted into a patient, i.e. an intraocular lens for cataract patients or a valve for glaucoma patients.
- Prosthetic shell – A device inserted into the empty eye socket after an evisceration or enucleation to maintain volume prior to fitting an artificial eye.
- Protectors (for instruments) – Lengths of plastic, silicone or rubber tubing, which are used to protect the tips of ophthalmic instruments during sterilization and storage.
- Pseudophakia – When the natural lens has been removed and replaced by an artificial intraocular lens.
- Pupillary Distance (PD) – Measured distance between the pupil on the left eye and the pupil on the right eye. This measurement is used when adjusting loupes and microscope eyepieces.
- Purchase order (purchase order number) – An order form used for ordering consumables, drugs, equipment etc. A specific numbering system is used to track purchases.
- Retinal detachment - Complete or partial separation of the retinal layers from the underlying choroid.
- Retinoblastoma – Malignant tumour in the posterior segment of the eye. It results from the malignant transformation of primitive retinal cells.
- Retrobulbar haemorrhage – Bleeding caused by a needle piercing a blood vessel close to the muscle cone at the apex of the orbit during the administration of a local anaesthetic.
- Risk register – A document developed by the facility to highlight potential risk areas/items. This assists the facility to put in place checking and risk prevention plans to prevent injury and harm to patients, staff and visitors.
- Safe Site Surgery (SSS) Check – A checking system used to prevent medical error from negatively impacting on a patient. This includes specific checking of patient identifiers, equipment, items/prosthesis needed for the surgery and other errors or equipment breakdowns.
- Scleral plugs – During vitreoretinal surgery, plugs are placed in to the surgical sites/holes (or trocar sites) to block (stop) fluid entering or exiting and to help maintain the pressure when the sites are not in use.
- Scrub nurse – Member of the surgical team responsible for management of the patient and to support other members of the scrubbed team during a surgical procedure. Duties include: maintenance of sterile field, instrument management, passing instruments to the surgeon, surgical count, monitoring of the patient, and liaison with the circulator nurse and anaesthetic team to prepare for the next patient.
- Scout nurse – Please see circulator nurse.
- Secondary glaucoma – Raised intraocular pressure caused by a pre-existing disorder of the eye, e.g. retained lens matter from an unplanned extracapsular cataract extraction.
- Sharps – Instruments with a cutting edge, e.g. needles and blades.
- Sign-In – A stage of the Safe Site Surgery Checking process that is performed during the pre-operative phase.
- Sign-Out – A stage of the Safe Site Surgery Checking process that is performed in the Operating Theatre prior to the closure of the wound.
- Silicone oil – An agent used during vitreoretinal surgery to apply pressure on retinal tears.
- Silicone mat – Rubber mat specifically designed to hold instruments to prevent damage. They can be washed and autoclaved.
- Speculum – An instrument used to hold open the eyelids to allow the surgeon to perform the surgery.
- Spores – Seeds of micro-organisms which are resistant to drying, heat and disinfectants.
- Sterilization – Complete destruction of all types of pathogenic micro-organisms.
- Sub – The word 'sub' means below or under. For example, a subconjunctival injection means injecting under the conjunctiva.
- Supine – Positioned flat on back.
- Surgical scrub – A process whereby members of the surgical team wash their hands and arms between each patient with a specific antimicrobial agent for a specific length of time (i.e. 5 minutes first wash and 3 minutes for every patient thereafter).
- Time-Out – A stage of the Safe Site Surgery Checking process that is performed in the Operating Theatre prior to draping.
- Titanium – Hard, lightweight, durable metal which does not rust.
- Trachoma – See Trichiasis.
- Triage – A system used in emergencies departments to determine patient care priorities. It ensures that those with urgent conditions are assessed first.
- Trichiasis – Condition in which eyelids (usually upper) scar,

the eyelashes turn inwards and rub on the eyeball resulting in corneal scarring and, in worst instances, corneal damage occurs. This is caused by a bacteria called Chlamydia Trachomatis.

- Trocars – Sharp-pointed cannulas used in vitreoretinal surgery to hold-open the pars plana entry points. They are removed at the end of the surgery.
- Toxic (toxicity) – Degree to which a substance has poisonous or adverse effects.
- Toxic Anterior Segment Syndrome (TASS) – An inflammation of the anterior part of the eye that requires immediate and urgent attention.
- Ultrasonic machine – Machine used in the instrument cleaning process. It uses high frequency sound waves to remove (blast away) debris on the surface of metal instruments.
- Viscoelastic – Temporary agent used during anterior surgery, i.e. cataract surgery to bump-up the anterior chamber.

Units

Blood sugar readings

- mmol Millimole

Length

- m Metre
- cm Centimetre
- nm Nanometre

Pressure

- lb/in² Pounds per square inch (psi)

Power/electricity

- W Watt
- kW Kilowatt
- Hz Hertz
- kHz Kilohertz
- MHz Megahertz

Temperature

- C° Celsius
- F° Fahrenheit

Volume

- L Litre
- ml Millilitre
- Tbs Tablespoon

Weight

- kg Kilogram
- g Gram
- mg Milligram

Appendix B

Templates Package.



Templates Package

- Instrument Tick List
- Hand Hygiene Tools
- Competency
- Stock Card
- Policies and Work Instructions
- Standing Orders
- Preference Cards
- Outreach Documents
- Patient Chart Documents
 - Safe Site Surgery Checklist
 - Pre-arrival care planning
 - Pre-surgery screening
 - Pre-anaesthetic nursing assessment
 - Peri-operative nursing notes
 - Doctor's post-anaesthetic orders (and discharge criteria)
 - Discharge instructions

Instrument Tick List

A tick list can be attached to an instrument tray. It is used as a reference by the scrub and circulating nurse at the beginning and end of each surgical case. They use this to check that everything they received on the tray (at the beginning of the case) has been returned (i.e. not left inside the patient or placed in the waste bin). The same list can be used by the sterilization team when receiving used trays from the OT. They start a fresh sheet once the instruments are ready to be re-cleaned.

If possible, the signed tick sheets should be placed into the chart of the patient who the instruments were used on.

If an instrument and/or sterilization tracking/sticker system is also in place, then the tracking labels/numbers can also be placed on the sheet. This will help to identify if the sterilization system and/or machine was involved in any post-operative infections.

A list can be made for each type of tray used at the facility.

Tracking Tool : Instrument Tray: ECCE basic Tray	Approved by: Revision Active Date Revision Date	Patient Label or hand written information, i.e. admission number, name																																																																			
Date Sterilized: _____ Sterilization load number: _____																																																																					
<table border="1" style="width: 100%; border-collapse: collapse; font-size: small;"> <thead> <tr> <th style="padding: 2px;">Type (and name if known, i.e. Vanna's)</th> <th style="padding: 2px;"># added by the Sterilization nurse before packing</th> <th style="padding: 2px;"># noted at commencement of surgery</th> <th style="padding: 2px;"># noted at the close of surgery</th> <th style="padding: 2px;"># noted returned after surgery (completed by the sterilization nurse)</th> </tr> </thead> <tbody> <tr><td style="padding: 2px;">Speculum</td><td></td><td></td><td></td><td></td></tr> <tr><td style="padding: 2px;">Toothed Forceps</td><td></td><td></td><td></td><td></td></tr> <tr><td style="padding: 2px;">Non-Toothed Forceps</td><td></td><td></td><td></td><td></td></tr> <tr><td style="padding: 2px;">Tying Forceps</td><td></td><td></td><td></td><td></td></tr> <tr><td style="padding: 2px;">Scissors</td><td></td><td></td><td></td><td></td></tr> <tr><td style="padding: 2px;">Squint Hook</td><td></td><td></td><td></td><td></td></tr> <tr><td style="padding: 2px;">Blade Handle</td><td></td><td></td><td></td><td></td></tr> <tr><td style="padding: 2px;">Iris repositior</td><td></td><td></td><td></td><td></td></tr> <tr><td style="padding: 2px;">Needleholder</td><td></td><td></td><td></td><td></td></tr> <tr><td style="padding: 2px;">Re-usable cannula</td><td></td><td></td><td></td><td></td></tr> <tr><td style="padding: 2px;">Sign/initials of nurse</td><td></td><td></td><td></td><td></td></tr> <tr><td style="padding: 2px;">Date</td><td></td><td></td><td></td><td></td></tr> </tbody> </table>	Type (and name if known, i.e. Vanna's)	# added by the Sterilization nurse before packing	# noted at commencement of surgery	# noted at the close of surgery	# noted returned after surgery (completed by the sterilization nurse)	Speculum					Toothed Forceps					Non-Toothed Forceps					Tying Forceps					Scissors					Squint Hook					Blade Handle					Iris repositior					Needleholder					Re-usable cannula					Sign/initials of nurse					Date					Notes (i.e. missing, damaged or issues raised by surgeon): _____ _____			
Type (and name if known, i.e. Vanna's)	# added by the Sterilization nurse before packing	# noted at commencement of surgery	# noted at the close of surgery	# noted returned after surgery (completed by the sterilization nurse)																																																																	
Speculum																																																																					
Toothed Forceps																																																																					
Non-Toothed Forceps																																																																					
Tying Forceps																																																																					
Scissors																																																																					
Squint Hook																																																																					
Blade Handle																																																																					
Iris repositior																																																																					
Needleholder																																																																					
Re-usable cannula																																																																					
Sign/initials of nurse																																																																					
Date																																																																					

Hand Hygiene Audit Tools

The below information has been extracted, from the Hand Hygiene Australia website with permission. <http://www.hha.org.au/AboutHandHygiene.aspx>

What is Hand Hygiene?

Effective Hand Hygiene is the single most important strategy in preventing health care associated infections.

Hand Hygiene

- Is a general term referring to any action of hand cleansing.
- Includes:
 - washing hands with the use of a water and soap or a soap solution, either non-antimicrobial or antimicrobial OR
 - applying a waterless antimicrobial hand rub to the surface of the hands (e.g. alcohol-based hand-rub).
- When performed correctly, hand hygiene results in a reduction of microorganisms on hands.

Hand hygiene practices have been universally poor among health care workers.

Why

- Heavy workloads - the busier you are the less likely you are to wash your hands.
- Time consuming - there just isn't enough time to wash your hands as often as you need to if using the traditional Hand Hygiene techniques.
- Hands don't appear dirty - Bugs are there even if you can't see them.
- Problems with skin irritation - frequent washing with soap and water removes skin lipids, and in some health care workers causes' dryness, skin irritation and damaged skin.
- Sinks poorly located - if it is hard to get to a sink you are less likely to use it.

Promotional posters



The Rules for Auditing



Rules	Extended Definition
Moment 1	HH Moment 1 is recorded only once the HCW touches the patient.
Moment 2	HH Moment 2 is recorded <u>immediately</u> prior to any procedure <ul style="list-style-type: none"> Once Hand Hygiene has been performed, nothing in the patient's environment can be touched prior to the procedure starting.
Moment 3	HH Moment 3 is recorded <u>immediately</u> after a procedure of body fluid exposure risk: <ul style="list-style-type: none"> Nothing else should be touched prior to performing hand hygiene Touching the outside of a drain or drainage bag (eg urinary catheter, wound drain, chest tube drain, CSF drain), even when the circuit is not broken, is considered a body fluid exposure risk Can be recorded as a stand alone HH Moment when there is a body fluid exposure risk, but no patient contact - e.g. cleaning a spill of vomit, urine or faeces.
Moment 4	HH Moment 4 is recorded after touching the patient <ul style="list-style-type: none"> Touching the patient surroundings after touching the patient is recorded as a single Moment 4. If after Moment 3 there is touching of the patient surroundings before leaving the patient zone this is recorded as a Moment 4.
Moment 5	HH Moment 5 is recorded when the HCW leaves the patient zone after touching the patient's immediate surroundings and the patient has not been touched. <ul style="list-style-type: none"> When multiple items in the patient surroundings are touched, only one Moment 5 is recorded.
Notes	
Before/After Moments	Generally for every 'before' Moment there should be an 'after' Moment recorded, unless the auditor does not witness the action. <ul style="list-style-type: none"> Moment 1 is generally followed either a Moment 3 or Moment 4 Moment 2 is generally followed by Moment 3 Moment 5 is a stand alone Moment as there is no patient contact. There are a few situations when two "afters" may be recorded sequentially, however you will <u>never</u> have a M1 and a M2 in a row.
Action missed if not observed	The HCW must be observed to perform HH as they approach the patient. If HH is not observed it should be recorded as a "missed" action (i.e. HH not performed).
Only audit what you observe	No "before" Moment can be recorded if auditing commences after a HCW is already touching a patient, or in the process of performing a procedure. No "after" Moment can be recorded unless the Moment is observed.
Curtains	Patient bed curtains are outside the patient zone and are frequently contaminated. Touching the curtains is equivalent to leaving the patient zone. HH should be performed between touching the curtains and touching the patient, and vice versa.
Double Moments	Two moments for HH can occur simultaneously e.g. when moving directly from one patient to another without touching anything in between. In this situation, a single HH action covers the two moments for HH, as Moments 4 and 1 coincide. When moving from touching a patient to performing a procedure on that same patient Moments 4 and Moment 2 coincide. When auditing in either situation, both Moments should be recorded as individual Moments on the data collection form.
When not to record a Moment	HHC is audited by HCW compliance with the 5 Moments; it is not audited by HCW performing a HH action. HH actions not corresponding to a recognised Moment are not recorded, e.g. when a HCW walks into a patient's room, does HH and walks out without touching anything. In this case no Moment had occurred, despite HH taking place, so no Moment can be recorded.



Hand Hygiene Observation - Coding Classification Sheet.

Code: Type of Healthcare Worker:

N	Nurse (Registered/Enrolled), Midwife
DR	Medical Practitioner
PC	Personal Care staff, includes PSA, AIN, PCW, wardsman, orderly, warders, ward/nursing assistants etc
AH	Allied Health, includes qualified staff engaged in duties of a diagnostic, professional or technical nature
D	Domestic, includes staff engaged in the provision of food and cleaning services, maintenance people.
AC	Administrative and Clerical, includes staff engaged in administrative and clerical duties.eg ward clerks etc
BL	Invasive Technician, includes phlebotomists, dialysis technicians etc
SN	Student Nurse, includes persons undertaking study to become nurses
SDR	Student Medical Practitioner, includes persons undertaking study to become a medical practitioner
SAH	Student Allied Health, includes persons undertaking study to become an allied health practitioner
SPC	Student Personal Care staff, includes persons undertaking study to become personal care staff
O	Other, includes persons not categorised elsewhere.

Code: Hand Hygiene Action:

Rub	HCW used ABHR
Wash	HCW washed hands with soap and water
Missed	Moment for HH observed but not performed

Code: Glove Use:

On	HCW put gloves on
Off	HCW removed gloves
Cont	HCW continued to wear the same pair of gloves Leave blank if no gloves

Code: Moments for Hand Hygiene:

- 1 Before touching a patient** - Before touching the patient in any way. This indication applies when the healthcare worker enters the patient's immediate surroundings to make contact with him or her. Eg. personal care activities, non-invasive observations, non invasive treatments, preparation and administration of oral medications, oral care and feeding, before touching any invasive medical device connected to the patient. Contact with the patient's surroundings during any of the above
- 2 Before a procedure** - Before performing any procedure where there is a risk of the direct introduction of a disease causing organism into the patient's body. - This indication applies before the insertion of a needle into a patient's skin, or into an invasive medical device. Preparation and administration of any medications given via an invasive medical device. Administration of medications where there is direct contact with a patient's mucous membranes. Insertion of, or disruption to, the circuit of an invasive medical device. Any assessment, treatment and patient care where contact is made with non-intact skin. Preparation of a sterile field.
- 3 After a procedure or body fluid exposure risk** - After any procedure or potential or actual body fluid exposure risk exposure - This indication applies at the conclusion of the procedure or after actual or potential exposure of the hands to a body fluid. Eg. after a Moment 2 contact, contact with a used urinary bottle / bedpan, with sputum either directly or indirectly via a cup or tissue, contact with used specimen jars / pathology samples, cleaning dentures, cleaning spills of urine, faeces or vomit from patient surroundings, after touching the outside of a drain.
- 4 After touching a patient** - After having touched the patient. This indication applies after a healthcare worker has touched a patient Eg. personal care activities, non-invasive observations, non invasive treatment, preparation and administration of oral medications, oral care and feeding, contact with the patient's surroundings during any of the above
- 5 After touching a patient's surroundings** - After touching the patient's immediate surroundings when the patient has not been touched. This indication applies when the healthcare worker leaves the immediate patient surroundings after having touched any objects. Patient surroundings include - bed, bed rails, linen, table, bedside chart, bedside locker, call bell/TV remote control, light switches, personal belongings, (including books, mobility aids), chair, foot stool. Eg. changing bed linen, holding a bed rail, clearing the bedside table.



Hand Hygiene Summary Sheet

Ward:





Hand Hygiene Australia
www.hha.org.au

Session No.	Date	Observer Initials	Duration of Session	Total Correct Moments	Total Moments	Running Total

Competency

Competency forms can be developed for a range of procedures and tasks in each facility, i.e. hand washing, scrubbing, gloving, or inserting an IVC. They are matched specifically to the employee's position. Depending on the countries governing nursing board and the employer, competencies can be mandatory or non-mandatory. Generally all employees undergo a competency review period (with a suitable educator/mentor) every 1-2 years. The below example from the Eye Bank Association of Australia and New Zealand – is a template for OT facilities to utilize and adapt to suit their own needs. In principle, templates need to be uniformed, with the same marking criteria or sign-off criteria, across the organisation.

Competency #: Care and Handling of Human Tissue for Ocular Application							
Competency Statement: <i>The employee cares for, handles and manages Human Tissue for Ocular Application (HTO) in accordance with facility policy and EBAANZ Guiding Principles</i>							
Competency Elements	Assessor's Assessment						
	0 = Not applicable to the position 1 = High proficiency 2 = Moderate proficiency 3 = Limited proficiency						
<ul style="list-style-type: none"> Demonstrates knowledge of facility policy and procedure, and EBAANZ Guiding Principles when working with HTO 							
<ul style="list-style-type: none"> Completes full tissue and recipient check and confirms the integrity of the HTO prior to checking it into the facilities stock and/or presenting to the Operating Theatre 							
<ul style="list-style-type: none"> Stores according to recommended range – as outlined in accompanied documentation 							
<ul style="list-style-type: none"> Demonstrates inclusion of HTO checks during Sign-In and Time-Out 							
<ul style="list-style-type: none"> Decants HTO on to the sterile field without contamination to self, others or HTO 							
<ul style="list-style-type: none"> Appropriately cares for discarded HTO (i.e. corneo-scleral rim) 							
<ul style="list-style-type: none"> Understands the procedures for research, recall, damaged or unused HTO and does so in accordance with the facilities quality management reporting system 							
Statement of Attainment The Competency Statement has been achieved by this employee to the level of: <input type="checkbox"/> Competent <input type="checkbox"/> Not Competent							
Evidence of achieving Competency Statement:							
Recent practice							
Observation of everyday performance							
Result of discussion/questioning/interviewing							
Result of formal assessment(s)/quizzes							
Continuing Professional Development activities							
Other <i>(please clarify)</i>							
<table style="width: 100%; border: none;"> <tr> <td style="width: 33%; border: none;">Employee Name _____</td> <td style="width: 33%; border: none;">Signature _____</td> <td style="width: 33%; border: none;">Date __/__/__</td> </tr> <tr> <td style="border: none;">Assessor's Name _____</td> <td style="border: none;">Signature _____</td> <td style="border: none;">Date __/__/__</td> </tr> </table>		Employee Name _____	Signature _____	Date __/__/__	Assessor's Name _____	Signature _____	Date __/__/__
Employee Name _____	Signature _____	Date __/__/__					
Assessor's Name _____	Signature _____	Date __/__/__					

1

Stock Card

This Stock Card template, from Aravind Eye Hospital, India, can be used to check and track stock when a computer based tracking systems is unavailable.

Example of a stock card

Item name:		Re-ordering level:				
Vendor information:						
Date	Document Ref	Details (including expiry date)	Number of items received	Number of items issued (taken out)	Current stock level (total number of items in stock)	

“Re-ordering level” refers to the minimum items you can safely have in stock before you order more. “Date” refers to the date of the document related to the items leaving or entering the store, if available, or simply the date items entered or left the store. “Document reference” is the number, or any other identifying reference, on the supplier’s invoice or on the internal authorisation for stock issued, as applicable. “Details” is for writing a brief narrative, such as “Received from (supplier’s name) or “Issued to... Ideally, include the expiry date of any received stock in the “Details” section.

(Excerpt from RD Thulsiraj Executive Director LAICO, Aravind Eye Care System – “Managing your eye unit’s supplies” – CEHJ Vol 24 Issue 76 – December 2011)

Policies and Work Instructions

Style varies around the world. Below is just one example. Ultimately, as long as there is uniformity across all documents then the system is secure. Particularly important is the heading (or footer) **document tracking bar** which states the: name, who approved it, which version it is and the dates it is valid for. The document tracking bar helps to make sure that staff are reading/using the most up-to-date version. All old versions should be saved and archived to prevent confusion. The style can work for both policies and work instructions.



WORK INSTRUCTION

Therapeutic Pathway & Protocols for Medications & Procedures

1. PURPOSE

To comply with current legislative requirements and promote safe patient care, Queensland Eye Hospital will ensure Treatment Pathways and Protocols which cover any medication orders and procedure performed will be used to:

- Prepare a patient for their consented procedure
- Prepare a therapeutic substance for use intra-operatively
- Treat a patient post-procedure

2. SCOPE

All QEH clinical staff and Visiting Medical Staff

3. SAFETY REQUIREMENTS

All treatment pathways and protocols must be:

- patient or condition specific;
- supported by or linked to appropriate clinical assessments
- linked to an organisational protocol relevant to standing orders
- time limited and subject to regular review annually
- signed and dated by the treating doctor
- available to staff working in the area

4. INSTRUCTIONS / STEPS

Treatment pathways and protocols for all areas are to be reviewed, updated and reprinted annually by staff working in the area and signed off by the treating doctor

- Pre-admission - anaesthetists fasting times and orders for medications (Insulin, oral hypoglycaemic drugs and blood thinners etc.)
- Pre-operative – pre-operative eye preparation and anaesthetist’s premedications
- Operating theatre – intracameral antibiotics, sun-conjunctival antibiotics, balanced salt solution infusion and intracameral Xylocaine
- PACU – post-operative care and discharge instructions

At time of annual review, all printed forms should be forwarded to theatre coordinators and will be handed to the doctors as a collective.

5. REFERENCES

WORK INSTRUCTION

6. RELATED DOCUMENTS

Therapeutic Pathway / Protocol Template – PACU

Therapeutic Pathway / Protocol Template – Pre-operative Anaesthetist Adult & Paediatric

Therapeutic Pathway / Protocol Template – Pre-operative Anaesthetist

Therapeutic Pathway / Protocol Template – Pre-operative Surgeon

Therapeutic Pathway / Protocol Template – Theatre

7. VERSION HISTORY

Version	Document Revision Date	Description of Change	Document Owner	Approval/s	Position Title	Next Review
15/02/2006	1					
31/09/2006			L Kawana		NUM	31/09/2007
13/05/2010	2		M Chinn	M Chinn	NUM	13/05/2011
21/08/2012	3	Policy format and update	H Scott	J Mcloughlin	Theatre Manager	21/08/2013
16/12/2014	4	Format to Work instruction	F O'Sullivan	J Mcloughlin	Theatre Manager	16/12/2015
30/03/2016	5	Updated to reflect current legislation	F O'Sullivan	J Mcloughlin	Theatre Manager	March 2019

Standing Orders

There are different names and terminology for 'Standing Orders'. These examples, from the Queensland Eye Hospital in Australia, are based on their state health department's terminology and requirements. It is important to find out what the local requirements are and develop standing orders to suit the local legislation, facility and need. In these examples, QEH use the term 'Therapeutic Pathway' and 'Therapeutic Order'. These are developed for various areas of the patient care, where different staff may be responsible for preparing and/or initiating treatment as directed by the attending surgeon. A standing order is developed for each procedure of each surgeon/anaesthetist.



Preoperative Therapeutic Pathways

Dr -----

PHONE NUMBER:

ROOMS:

Fasting Times Adults		
	GA	MLA
Food		
Fluids <i>Tea or coffee with a small amount of milk, clear juice or water</i>		
Clear Fluids		

Fasting Times Paediatrics		
	Up to 1 Year Old	1 Year and Over
Food		
Formula / Breast Milk		
Clear Fluids		

Premedication Adults

ALL ELECTIVE SURGERY

Drug name

- How and when to administer

Special notes:

Premedication Paediatrics

Dr ----- will review the child on admission and order pre-medication as required.

Dr ----- will assess at the pre-operative consultation whether a parent will go through to theatre.



Preoperative Therapeutic Pathways

Dr -----

Non-Insulin Dependent Diabetic	
Insert instructions	
MORNING LIST	
AFTERNOON LIST	

Insulin Dependent Diabetic	
Insert instructions	
AM LIST	
MORNING LIST	
INSULIN PUMPS	

BODY MASS INDEX (BMI)
Call Dr ----- if BMI is over 40

Anticoagulants
If patient is on anticoagulants contact the surgeon.



Dr -----

Therapeutic Pathways - Theatre

Intracameral Antibiotic Order	
Drug	
Dispensing Instructions	

Introcular Fluid Order (i.e. Balanced Salt Solution Infusion)	
Drug	
Preparation	

Intracameral Xylocaine 1%	
Drug	
Preparation	

Special Notes

For patients with drug sensitivity please check with Dr -----.

Preference Cards

These examples from the Queensland Eye Hospital in Australia can be adapted to suit the facility, surgeon and the procedure. Keep a copy in a central place, and another copy in the OT area for daily use. A preference card is developed for each procedure performed by each surgeon/anaesthetist. They can be continually up-dated by the nursing staff and used to help set-up the OT each day.

Surgeon preference cards

	Dr Yung	Procedure Name: Phacoemulsification & IOL implant				
PREP:						
BOWLS:						
DRAPES:						
TRAYS:						
STERIPEEL:						
EXTRAS:						
STANDBY ITEMS:						
SUTURES:						
DRUGS:						
DRESSING:						
EQUIPMENT:						
SPECIAL NOTE:	(i.e. scrub nurse stands to the left side of the surgeon, or surgeon is left handed etc.)					
UPDATED:						



Dr Yung

Procedure Name: Phacoemulsification & IOL implant

PROCEDURE:

If

Vision Blue - Injects air (leave air in syringe)

Limbal Relaxing Incision - first part of procedure

Anterior Vitrectomy

Kenacort A-40

Toric Lens

R/O IOL need:

I/O IOL need:

UPDATED:

Anaesthetic Preference Card

	<p>Dr Singh Anaesthetic Type: Local Peribulbar Block</p>
<p>Procedure:</p> <p>Glove size:</p> <p>Delivery of O2:</p> <p>Monitoring:</p> <p>Drugs:</p> <p>Needles:</p> <p>Syringes:</p> <p>Cannula:</p> <p>Extras:</p> <p>Weigh the patient:</p> <p>Special Notes:</p> <p>Updated:</p>	

Outreach Documents

There are several documents and tracking materials that can be used when planning for an outreach visit. This section provides examples from Aravind Eye Hospital, India.

Example of an admission planning sheet

Camp admission, Operation and Discharge planning for the week ending 01.02.2015							
SI NO	Place of Camp & Admission Date	Place of admission	EXP. IP	Anticipated Surgery date	Discharge Date	Organizer name	District
1	Keeranur 28.01.2015(Wed)	Camp Hospital	500	29.01.2015 (Thu)	31.01.2015 (Sat)	Vivekanandan	Pudukottai
2	Vadakkampatti (Token) 29.01.2015(Thu)	Camp Hospital	35	30.01.2015 (Fri)	31.01.2015 (Sat)	Murugesan	Madurai
3	Kallanthiri(Token) 29.01.2015(Thu)	Camp Hospital	47	30.01.2015 (Fri)	31.01.2015 (Sat)	Murugesan	Madurai
4	Okkur 29.01.2015(Thu)	Camp Hospital	50	30.01.2015 (Fri)	01.02.2015 (Sun)	Vivekanandan	Sivagangai
5	Ramanathapuram 31.01.2015(Sat)	Camp Hospital	50	02.02.2015 (Mon)	04.02.2015 (Wed)	Ramesh	Ramnad
6	Mecheri 31.01.2015(Sat)	Camp Hospital	150	02.02.2015 (Mon)	04.02.2015 (Wed)	Jeyaram	Salem
7	Neelagiri 31.01.2015(Sat)	Camp Hospital	60	02.02.2015 (Mon)	04.02.2015 (Wed)	Selva Kumar	Thanjavur
8	Kottathur 01.02.2015(Sun)	Free Hospital	75	02.02.2015 (Mon)	04.02.2015 (Wed)	Kumar	Trichy
9	Meenakshi Nagar 01.02.2015(Sun)	Free Hospital	100	02.02.2015(Mon) 03.02.2015(Tue)	04.02.2015 (Wed)	Murugesan	Madurai
10	Rasipuram 01.02.2015(Sun)	Camp Hospital	150	02.02.2015(Mon) 03.02.2015(Tue)	05.02.2015 (Thu)	Jeyaram	Namakkal
11	Thirunageswaram 01.02.2015 (Sun)	Camp Hospital	60	02.02.2015(Mon) 03.02.2015(Tue)	05.02.2015 (Thu)	Selva Kumar	Thanjavur
1. T.Kallupatti (Token) IP-50, brought on 04.02.2015 (Wed), Discharge on 07.02.2015 (Sat)					Saturday admission		260
2. Palakurichi (Token) IP-75, brought on 04.02.2015 (Wed), Discharge on 07.02.2015 (Sat)					Sunday admission		385
3. Thirupparankundram (Token) IP-75, brought on 05.02.2015(Thu) Discharge on 07.02.2015 (Sat)					Total		645

Aravind Eye Hospital - Stores Department							
Indent form for Eye Screening Camps							
Date of Camp:		<input style="width: 100%;" type="text"/>		Exp. OP:	<input style="width: 100%;" type="text"/>		
Place of Camp:		<input style="width: 100%;" type="text"/>		Name of Sr.MLOP i/c	<input style="width: 100%;" type="text"/>		
Camp organizer:		<input style="width: 100%;" type="text"/>					
FORMS AND STATIONARY ITEMS FROM STORES						Form - A	
S.No	Name of the supplies	Required Quantity				Issued Quantity	Returned Quantity
		<300	300-500	500-800	800-1500		
1	OP Record Camp	300	600	1000	2000		
2	Identity Card Camp	300	600	1000	2000		
3	Post Operative Record	75	150	300	500		
4	Pre Operative Record	75	150	300	500		
5	IOL Discharge Summary	75	150	300	500		
6	Declaration Card Camp	75	150	300	500		
7	Continuation Card free	100	200	300	400		
8	Notice About F.H	25	25	50	50		
9	Cataract Surgery Record	5	5	5	10		
10	Cataract Discharge Summary	5	5	5	10		
11	Stay Pass for Attenders	5	5	10	10		
12	Drug Pad F.H	3	5	10	10		
13	Glass pad F.H	1	2	4	7		
14	Paper Pin Box	1	1	2	2		
15	Tin Tag	1	1	2	2		
16	Cell big	2	4	8	16		
17	Cell medium	2	2	2	2		
18	Stapler	2	2	2	3		
19	Stapler Pin	1	2	2	2		
20	Punching Machine Single Hole	1	1	2	2		
21	Soap	1	1	3	3		
22	Match box	1	1	1	1		
23	OP Register Camp	2	2	3	4		
24	Rope (6 metres)	2	2	2	2		
25	Bed sheet	1	2	3	4		
26	Stickers - Surgery Review	30	40	60	80		
27	Stickers - Diabetic	30	40	60	80		
28	Stickers - Cardiac	30	40	60	80		
29	Stickers - Asthmatic	30	40	60	80		
30	Stickers - Hypertensive	30	40	60	80		
31	Stickers - One Eyed	30	40	60	80		
32	Stickers - Duct partially free	30	40	60	80		
33	Stickers - Plain Small	30	40	60	80		
34	Special Case Card for Systemic problem patients	15	25	40	75		
35	Fee Recommendation Card	5	5	5	5		

Instruments, Equipments & Electrical Items
Form - B

S.No	Name of the supplies	Required Quantity				Issued Quantity	Condition at the time of Issue	Returned Quantity	Condition at the time of Return
		<300	300-500	500-800	800-1500				
1	Tonometer with chart	1	2	3	4				
2	Cell Torch	3	3	3	4				
3	Electric Torch	4	5	7	10				
4	B.P Apparatus	1	2	3	3				
5	Sthethos cope	1	2	3	3				
6	Switch board	1	2	2	3				
7	Station Number Chart	7	7	7	7				
8	Wiper Jar (Big / Small)	1	1	1	2				
9	Syringe Box (Big / Small)	1	1	1	2				
10	Basin	2	2	1	3				
11	Medicine Tray	1	2	2	3				
12	Trunk Box	1	1	1	1				
13	Lock & Key	1	1	1	2				

Refraction items for Regular Screening Camps
Form - C

S.No	ITEM NAME	REQUIRED QTY				ISSUED QTY	RETURNED QTY
		<300	300-500	500-800	800-1500		
1	Trial set	2	3	4	5		
2	Trial Frame	2	3	4	5		
3	Streak Retinoscopy	2	3	4	5		
4	Torch (Pen)	2	3	4	5		
5	Torch cell (for Retinoscopy)	1	1	1	2		
6	Snellen chart	8	12	16	20		
7	Cubicle set w ith cloth	2	3	4	5		
8	Sw itchBoard - big	1	2	2	2		
9	Sw itch board-small	2	3	4	5		
10	Wire w ith holder and bulb	3	4	5	6		
11	Wire for extension (6 meters)	1	1	2	2		
12	Stapler w ith pin	2	3	4	5		
13	Multi Pin Hole set						
14	IPD Ruler						
15	Near Vision chart						

Check list for Medicines / Antiseptics
Form - D

S.No	ITEM NAME	REQUIRED QTY				ISSUED QTY	RETURNED QTY
		<300	300-500	500-800	800-1500		
1	Tropicamide Plain (E/D)	3	4	4	8		
2	Tropicamide Plus (E/D)	3	4	6	8		
3	Homide (E/D)	2	2	2	2		
4	Cyclopent	1	1	2	3		
5	Lignocaine 4%	2	3	4	7		
6	Antibiotic Drops	3	4	5	8		
7	Zoxan Oinment	1	1	2	3		
8	Betnesol	1	1	2	2		
9	Timolal 0.5%	1	1	2	2		
10	Pilocorp 2%	1	1	2	2		
11	Steroid Oinment	1	1	2	2		
12	Atropine Ointment	1	1	2	2		
13	Saline bottle	1	1	1	2		
14	Syringe 2 ml.	2	4	6	8		
15	Needle 26 G	2	2	4	4		
16	Dettol	30ml	30ml	60ml	60ml		
17	Spirit	30ml	30ml	60ml	60ml		

Example of a post-visit data collection form

Comprehensive Screening Camp - Post Camp Report - Data Collection Form										
Place					Date			Organizer		
Counsellor				Refractionist				Optician		
1. Outpatients details: (by Patient Counsellor)										
Actual OP seen:		Age Gp:	0-15		16-40		40-50		>50	
2. Gender wise details: (by Medical Record Dept)	Sex	IMC	MC	Glaucoma	Retina	Ref. Errors	Childhood Blindness	Others	Case sheets missed	Total
	Male									
	Female									
	Total									
3. Cataract details: (by Patient Counsellor)										
Immature Cataract		Advised surgery		Admitted surgery		A. Not admitted due to systemic condition			B. Not willing	
Details are given below for the patients 'advised for surgery but not admitted':										
A. Systemic Condition					B. Not willing for Surgery					
Reason	No.				Reason	No.		Reason	No.	
Diabetic					Went home & not turned			Able to pay		
Hypertensive					Personal Commitment			Blind refusal		
Cardiac					Fear of Surgery			Others		
Asthma					No attender					
Ulcer					Festival					
Others					Prefer next camp					
4. Specialty diagnosis details: (by Patient Counsellor)										
Specialty	Identified	Referred	Registered	Specialty	Identified	Referred	Registered			
Glaucoma				Trachoma						
Retina				Oncho						
Diabetic Retinopathy				Other 1.						
Childhood blindness				Other 2.						
Cornea				Other 3.						
Orbit				Other 4.						
Uvea				Other 5.						
Neuro				Diabetic pts. Seen						
Data Source:										
Patient Counsellor	S.No.1,3,4,5			Refractionist	S.No.6		Optician	S.No.7		
Camp Organizer	S.No.8			MRD	S.No.2					

5. Specialty Referral details (by Patient Counsellor)

S.No.	Camp OP No.	MR No.	Patient name	Mobile no.	Referred for	Followup
1						
2						
3						
4						
5						
6						
7						
8						
9						
10						
11						
12						
13						
14						
15						

6. Refraction details: (by Refractionist)

Refraction done IMC/Early Cat Lens Changes Same PG
 Exclusive Refractive error (other than Cat. & Spty) Glasses Prescribed

7. Optical dispensing details: (by Optician)

Glasses Ordered On the spot delivery (Readymade) On the spot delivery (Fitting)

8. Remarks by Camp Organizer: Geographical Information System used for Campaign Yes NO

Publicity Campaign: Hand bills: Posters/boards: Audio announcement:

Other methods:

Villages & Popln. covered: No. of villages from where patients have attended

Specific Learning in this camp / Reasons for Success or Failure:

Over all assessment by the Camp Organizer based on perf. parameters: Best Good Fair Poor

Signature: Doctor Camp Organizer Counselor Refractionist Optician MRD

Patient Chart Documents (Adult Care)

Templates in this section are supplied by the Pacific Eye Institute – Fiji, a dedicated day-stay eye care facility and Duke University Hospital (DUH) – USA. DUH provide a comprehensive example of patient chart documentation required in larger general hospitals – that care for a wide range of health needs – not just ophthalmology. This example was selected for this text as ophthalmic services in many lower resource parts of the world also take place in general hospitals. Finding a way to develop forms that will work for multiple specialties remains an essential skill for many healthcare teams.

The examples shown may need to be adapted for paediatric care, and to suit local needs, policies and practice.

Safe Site Surgery Checklist

This template has been adapted from the World Health Organizations original Tool. It has been adapted to suit local practice and specifically ophthalmic care in lower resource locations. This tool can be adapted to suit any surgery setting, surgery type and department (i.e. OT, minor procedure clinic, laser clinic and mobile and rural/remote settings). Staff must use the same check sheet for each patient, at each stage of their procedure.

 <p>Form: Safe Site Surgery Checklist</p>		<p>Approved by: _____</p> <p>Revision 1</p> <p>Active Date Add</p> <p>Revision Date Add</p>	
<p style="text-align: center;">SIGN IN</p> <p style="text-align: center;">Before anaesthetic is given</p> <p>Confirm patient Identity</p> <p><input type="checkbox"/> Consent completed & signed</p> <p><input type="checkbox"/> Correct site and side marked</p> <p><input type="checkbox"/> Allergies/n.a _____</p> <p><input type="checkbox"/> IOL/prosthesis available</p> <p><input type="checkbox"/> Fasting status</p> <p><input type="checkbox"/> Other equipment needed?</p> <p>Pre-Operative Nurse Signature:</p>	<p style="text-align: center;">TIME OUT</p> <p style="text-align: center;">Before patient is prepped and draped</p> <p><input type="checkbox"/> Introduce all team members</p> <p><input type="checkbox"/> Confirm patient Identity</p> <p><input type="checkbox"/> Consent completed & signed</p> <p><input type="checkbox"/> Correct procedure type</p> <p><input type="checkbox"/> Correct site and side</p> <p><input type="checkbox"/> Correct IOL/prosthesis</p> <p><input type="checkbox"/> Surgical, anaesthetic or nursing concerns (equipment and sterility checks completed etc.)</p> <p><input type="checkbox"/> Pulse Oximetry on</p> <p><input type="checkbox"/> Antibiotic prophylaxis</p> <p>OT Team Representative Signature:</p>	<p style="text-align: center;">SIGN OUT</p> <p style="text-align: center;">Before patient leaves the OT</p> <p><input type="checkbox"/> Needle count complete (documented in count sheet)</p> <p><input type="checkbox"/> Specimen labelled, documentation completed ready for transfer to the lab</p> <p><input type="checkbox"/> Equipment problems</p> <p><input type="checkbox"/> Supervisor notified of issues</p> <p>Comments:</p> <p>_____</p> <p>_____</p> <p>_____</p> <p>Circulator Nurse Signature:</p>	

M1512
Rev. 10/06



Duke University Hospital
DUKE UNIVERSITY HEALTH SYSTEM

**PREOPERATIVE PLAN OF CARE
AND PATIENT EDUCATION**

Interview: Telephone In Person

Scheduled Surgical Date: _____

Diagnosis: _____

Emergency Contact Name: _____ Telephone #: _____

The day/evening before surgery the patient can be contacted at: () _____

ADVANCE DIRECTIVES / ADVANCE INSTRUCTIONS

Does patient have a North Carolina Advance Directive? home hotel other cell phone
 Yes No N/A
 If Yes, Copy in chart Copy unavailable Wish to complete new advance directive Family to bring copy
 If No, Wish to complete Does not wish to complete Literature Provided

Duke Hospital

Out Patient Surgery
 Out Patient Bed-Duke Hospital (OPS)
 Same Day Admission (SDA)
 Other: _____

Ambulatory Surgery Center (ASC)

ASC
 Recovery Care Center (RCC)
 GI Procedure -ERCP
 ECT

Patient ready to learn: Yes No If no, reason: _____

Explanation provided to: Patient Parent/Guardian Spouse Other: _____

Focus: Knowledge deficit related to: Surgery Anesthesia Other: _____

Additional problems/co-morbidities: _____

Topics Reviewed/Handout(s)

- NPO guidelines
- Pain Management (scale, score, PCA)
- Smoking and ETOH
- Turn/cough/deep breathing
- Equipment, IV, Drain, etc. anticipated
- Dressings anticipated
- Admission Process
- Preoperative Holding patient flow
- Transportation and assistance after receiving sedation
- Post-Op constipation

Patient Care

Patient instructed on surgical antimicrobial scrub Yes N/A

Adverse Food or Drug Reactions? Yes No

If yes, list _____

Uses Herbal products? Yes No

If yes, list _____

Other (i.e. Dentures/partials, eye glasses): _____

Response: verbally states understanding of information: Yes No

If No - Reason: _____

Comments: _____

Signature/Title: _____ **Date / Time:** _____



M1512

M0145 Rev. 08/10	Duke University Hospital DUKE UNIVERSITY HEALTH SYSTEM PREPROCEDURE HISTORY & PHYSICAL EXAM PREOPERATIVE SCREENING UNIT	Addressograph Name _____ History number (inpatient) _____ Birthdate (clinic and PDC) _____					
Age: _____	Height (cm): _____ <input type="checkbox"/> Actual <input type="checkbox"/> Stated	Weight (kg): _____ <input type="checkbox"/> Actual <input type="checkbox"/> Stated	Temp: _____	Pulse: _____	BP: _____	Pulse Ox: _____	
Pain Score: _____ <input type="checkbox"/> Unable to Assess Scale Used: <input type="checkbox"/> Numeric (0-10) <input type="checkbox"/> Faces <input type="checkbox"/> Thermometer							
1. Location of pain: _____ When was the pain first noticed? _____							
2. Pain Frequency: <input type="checkbox"/> Never <input type="checkbox"/> Monthly <input type="checkbox"/> Weekly <input type="checkbox"/> Daily <input type="checkbox"/> Hourly <input type="checkbox"/> Constant							
3. What word best describes the pain? <input type="checkbox"/> Burning <input type="checkbox"/> Shooting <input type="checkbox"/> Stabbing <input type="checkbox"/> Aching <input type="checkbox"/> Dull <input type="checkbox"/> Sharp <input type="checkbox"/> Other _____							
Signature: _____ Title: _____ Pager#: _____ Date: _____ Time: _____							
Procedure: _____							
Diagnosis: _____ Date of Surgery: _____							
Adverse Food and Drug Reactions: _____							
Medical History / Systems Review (Check positives, Ø indicates pertinent negatives) HPI _____ _____ _____							
Muscular/Skeletal Movement <input type="checkbox"/> WNL <input type="checkbox"/> Impaired - describe _____ ADLs <input type="checkbox"/> Independent <input type="checkbox"/> Needs Assistance - describe _____			Past Surgical History <input type="checkbox"/> Cardiac Surgery - see cardiac hx <input type="checkbox"/> Cholecystectomy <input type="checkbox"/> Laminectomy <input type="checkbox"/> BTL <input type="checkbox"/> T&A <input type="checkbox"/> TAH <input type="checkbox"/> Cataract <input type="checkbox"/> Appendectomy <input type="checkbox"/> Eye Problems w/ anesthesia <input type="checkbox"/> none <input type="checkbox"/> N/V				
Cardiac <input type="checkbox"/> WNL <input type="checkbox"/> Exercise tolerance: _____ <input type="checkbox"/> CAD <input type="checkbox"/> Dysrhythmia <input type="checkbox"/> Stress Test <input type="checkbox"/> Angina <input type="checkbox"/> HTN <input type="checkbox"/> MI <input type="checkbox"/> Dyspnea <input type="checkbox"/> CABG <input type="checkbox"/> Valvular Disease <input type="checkbox"/> CHF <input type="checkbox"/> Angioplasty <input type="checkbox"/> SBE prophylaxis <input type="checkbox"/> Pacemaker (Date) <input type="checkbox"/> ECHO			Pulmonary <input type="checkbox"/> WNL <input type="checkbox"/> PE <input type="checkbox"/> Cough / URI <input type="checkbox"/> Asthma <input type="checkbox"/> Sinusitis / Allergy <input type="checkbox"/> COPD <input type="checkbox"/> Pneumonia <input type="checkbox"/> Sleep Apnea <input type="checkbox"/> Tobacco abuse				
GI <input type="checkbox"/> WNL <input type="checkbox"/> Reflux <input type="checkbox"/> PUD <input type="checkbox"/> Hepatitis		Hematology <input type="checkbox"/> WNL <input type="checkbox"/> Transfusion <input type="checkbox"/> Anticoagulated <input type="checkbox"/> Sickle Cell <input type="checkbox"/> Anemia <input type="checkbox"/> Bleeding <input type="checkbox"/> DVT		GU <input type="checkbox"/> WNL <input type="checkbox"/> CRI <input type="checkbox"/> Renal Failure <input type="checkbox"/> Dialysis <input type="checkbox"/> Symptoms of UTI <input type="checkbox"/> Renal Stones <input type="checkbox"/> BPH <input type="checkbox"/> Prostate CA <input type="checkbox"/> Incontinence		Psych <input type="checkbox"/> WNL <input type="checkbox"/> Anxiety <input type="checkbox"/> Depression <input type="checkbox"/> Claustrophobic Social <input type="checkbox"/> Smoker <input type="checkbox"/> Occupation _____ <input type="checkbox"/> ETOH <input type="checkbox"/> Marital Status _____ <input type="checkbox"/> Street Drugs	
Neuro <input type="checkbox"/> WNL <input type="checkbox"/> CVA <input type="checkbox"/> TIA <input type="checkbox"/> Syncope <input type="checkbox"/> Sz		Skin <input type="checkbox"/> WNL <input type="checkbox"/> Other _____ Other _____		GYN <input type="checkbox"/> LMP _____ <input type="checkbox"/> Postmenopausal <input type="checkbox"/> Possibility of Pregnancy <input type="checkbox"/> Yes <input type="checkbox"/> No		Family Hx <input type="checkbox"/> HTN <input type="checkbox"/> Cancer <input type="checkbox"/> Anesthesia <input type="checkbox"/> DM <input type="checkbox"/> Cardiac Diabetic: <input type="checkbox"/> Yes <input type="checkbox"/> No Pt dx'd this morning <input type="checkbox"/> Yes <input type="checkbox"/> No Level _____ Ck'd in POSU <input type="checkbox"/> Yes <input type="checkbox"/> No Level _____ Time _____ Signature _____	
Ortho <input type="checkbox"/> WNL <input type="checkbox"/> RA <input type="checkbox"/> OA <input type="checkbox"/> Neck pain <input type="checkbox"/> LBP							

M0145
8/10

**PREPROCEDURE HISTORY &
PHYSICAL EXAM
PREOPERATIVE SCREENING UNIT**

Name: _____
History number (optional): _____
Birthdate (circle and POC): _____

CURRENT MEDICATIONS — take on morning of surgery

See attached sheet

-
-
-

-
-
-
-
-
-

Airway

Mallampatti: I III
Score: II VI

Teeth

Dentures: _____
Partials: _____
Crowns: _____
Bridge: _____
C-spine ROM: _____ WNL

1. ENT

WNL

Bruits

6. Musculoskeletal

2. Chest

WNL

3. Heart Sounds

S₁S₂

7. Neuro

reflexes

4. Abdomen

Soft non-tender

8. Skin

5. Extremities

edema

Labs

T&S

Na | Cl | BUN | Glu | WBC | Hgb | Pit
K | HCO₃ | CR | Hct

X-ray

ECG

CXR

Echo

Consults

PFT's

FEV₁

FEV₁/FVC

%

Date

REVIEW

Problem List

ASA Classification

- I IV
- II V
- III Emergency

Anticipated Post Procedure Care

- Ambulatory
- Needs inpt. bed for recovery
- SDA
- ICU

Patient Requests / Concerns

Anesthesia Discussed

- GA Nerve Block
- MAC Spinal / Epidural

Clinician Signature: _____ Pager #: _____ Date: _____ Time: _____

POSU Attending Comments

Signature: _____ Title: _____ Pager #: _____ Date: _____ Time: _____

Anesthesiologist Pre Procedure Review (to be completed immediately prior to anesthesia)

- Agree with above
- No significant changes
- Anesthesia consent signed
- Operative Site Marked

Signature: _____ Title: _____ Pager #: _____ Date: _____ Time: _____

Attending Surgeon Review / Comments (n/a if surgeon used other H&P)

No significant changes

Signature: _____ Title: _____ Pager #: _____ Date: _____ Time: _____

Post Procedure Anesthesia Visit(s)

Cardiopulmonary Status:

Level of Consciousness: Modified Ramsay Score _____ (1-6)

Complications occurring during anesthesia or Post anesthesia recovery.

Plans for follow-up care and observations:

Pain Assessment

Score: _____ Unable to Assess

Scale: Numeric (0-10) Faces Thermometer

Location:

- Description: Burning Shooting Stabbing
- Aching Dull Sharp
- Other: _____

When noticed: _____

Satisfied with Pain Management Regimen:

- Yes No

Signature: _____ Title: _____ Pager #: _____ Date: _____ Time: _____

M1513
7/00
15430



DUKE UNIVERSITY HOSPITAL

PREANESTHESIA NURSING ASSESSMENT

Date/Time of Arrival: _____

Height: _____ cms. Weight _____ kgs. Blood glucose: _____ -POCT (point of care testing) -Lab

Vital Signs:

Temperature: _____ -Oral -Tympanic -Axillary -Rectal

Heart Rate: _____ -Apical -Radial Rhythm strip obtained: -Yes -No -N/A

Respirations: _____ -Regular -Irregular -Breath sounds clear bilaterally -Other _____

Blood Pressure: -Right arm _____ -Left arm _____ -Other _____

Room Air SaO2 _____ SaO2 _____ with _____ liters of oxygen

PAIN HISTORY:

1. Does the patient have pain currently? -Yes -No If yes, Pain Score: _____

Pain Scale used: -Pediatric Cries (0-6 months) -Pediatric Objective -Faces -Thermometer -Numeric

2. Has this pain been a long term problem requiring routine pain medication or medical treatment? -Yes -No

3. Does the pain condition involve the surgical area? -Yes -No

4. Children <12 years of age:

a) How does the caregiver know when the child is having pain? _____

b) What word does the child use for pain? _____

Pediatric Patients: Consent given for adult to accompany child to OR: -Yes -No

Patient Preparation: Surgical Site Marked: -Yes -No -N/A Contacts: -Removed -N/A
 Voided: -Yes -No -N/A Glasses: -Removed -N/A
 Bowel Preparation: -Yes -No -N/A Dental Appliance: -Removed -N/A
 Shaved/Prepared: -Yes -No -N/A Hearing Aid: -Removed -N/A
 Other _____

IV Site: -Left -Right -Hand -Arm -Leg -Other _____
 IV Gauge -20 -18 -16 -Other _____

IV Started: -Normal Saline - amount of fluid hung: _____
-Lactated Ringers - amount of fluid hung: _____ -Other _____ /Amount _____

Medication Given	Dose	Solution	Route	Time

Signature/Title: _____ Date: _____

Duke University Hospital
DUKE UNIVERSITY HEALTH SYSTEM
PERIOPERATIVE NURSING PLAN OF CARE

PREOPERATIVE PHASE
 NURSING DIAGNOSIS 1: Knowledge deficit related to impending surgical intervention.
 NURSING DIAGNOSIS 2: Anxiety related to impending surgical intervention.

Date: / / Arrival Time: _____
 Comment signed: Yes No
 Surgical site confirmed by patient? Yes No Site: _____
 Allergies: Yes No List allergies and reactions: _____ NPO since: _____
 Pre-op ID bracelet: Yes No Patient belongings: _____ Item: _____
 Ophthalmologic: Diabetic Yes No Eye dilated Yes No OD: Yes No N/A
 Signature: _____ NALP/RN

PHYSICAL ASSESSMENT / OBSERVATION

A Support Systems to OR
 IV Ventr. Supp Respirative Flushbed Cardio-Pulmonary
 Foley NG Tube IABP Non-occlusive Friction Cool Cyanosis
 Drain Ostomy Disoriented Warm Cough
 A-line Oxygen Other ROM Limited Dry SOB
 PA Catheter N/A Other Amputation Unusual Masks No Distress
 Other Other

B Psychological
 Calm/Relaxed Language Barrier Implement comfort and safety measures.
 Crying Hearing Impairment Give emotional support/reassurance.
 Withdrawn Speech Impairment Encourage patient to ask questions and verbalize concerns.
 Restless Visual Impairment Encourage patient to ask questions and verbalize concerns.
 Talkative Diagnosed Retardation Give clear, concise explanations.
 Quiet No Apparent Limits Communicate patient concerns to other health members.
 Other Other Orient patient to environment.

Signature: _____ LPN / RN

PATIENT OUTCOME 1: Patient/family verbalizes basic understanding of peri-operative activities prior to surgery.
 Comments: _____

PATIENT OUTCOME 2: Patient demonstrates adaptive coping strategies.
 Comments: _____

Signature: _____
 Procedure: _____
 Surgical hair dippod: Yes No N/A
 Surgical Atr/RN _____

Surgeon: _____ Assistant: _____
 Circulator: _____ RN Relief: _____ RN Time: _____
 2nd Circulator: _____ RN Relief: _____ RN Time: _____
 Relief: _____ RN Time: _____ RN Time: _____
 Scrub: _____ ORTRN Relief: _____ ORTRN Time: _____
 2nd Scrub: _____ ORTRN Relief: _____ ORTRN Time: _____
 Relief: _____ ORTRN Time: _____ ORTRN Time: _____
 OR Attendant _____ Relief: _____

POST-OPERATIVE PHASE

WOUND CARE
 Dressing None (Site) _____
 Soft _____
 Pressure _____
 Occlusive _____
 Flanzer _____
 Splint _____
 Cast _____
 Eye Pad/Shield _____
 Ointment/Solution _____ Betadine Vaseline Xeroform Adaptic Gauze

APPLIANCE None Type _____ Site _____
 None Type _____ Site _____
DRAINS None Type _____ Site _____
 None Type _____ Site _____
 None Type _____ Site _____
 None Type _____ Site _____
 None Type _____ Site _____

L & D: Closing time: _____ Transfer time: _____ N/A

DISCHARGE FROM OPERATING ROOM
 Tubes and Drains secure? Yes No N/A Patient cleaned Yes No N/A
 Cavity plate removed Yes No N/A Skin integrity Intact Other
 Report given Yes No Report given to _____ Time: _____
 Transferred to PACU I PACU II STS L & D PACU Specialty ICU _____ Nursing Unit _____ Other
 Transferred by OR Nurse Anesthesia Surgeon/Resident Transporter Other

PATIENT OUTCOME 3: Infection control measures and technique implemented throughout peri-operative phase.
 COMMENTS: _____

PATIENT OUTCOME 4: Patient tolerated procedure with no apparent injury.
 COMMENTS: _____

ADDITIONAL DIAGNOSIS (if needed) / COMMENTS / NURSING NOTES

NURSING DIAGNOSIS 5:
 PLAN AND IMPLEMENTATION:
NURSING OUTCOME 5:
 COMMENTS: _____

DATE: _____ SIGNATURE(S) _____ RN _____

MS05 Rev. 10/08



INTRAPERATIVE PHASE

NURSING DIAGNOSIS 3: Potential for infection.

NURSING DIAGNOSIS 4: Potential for injury and tissue impairment.

L & Dr: N/A Time patient in room _____ Incision time _____ Anesthesia type _____

WOUND CLASSIFICATION 1. Clean 2. Clean contaminated 3. Contaminated 4. Infected 5. No wound

POSITION

- Supine
- Prone
- Lateral
- Lithotomy
- Jackknife
- Frogged leg
- Sitting
- Beach Chair
- Legs uncrossed
- Other _____

POSITIONAL AID

- Pillow
- Safety belt across thighs
- Foam pads
- Lateral
- Armboard R L
- Overhead armboard R L
- Breast armboard R L
- Frogged leg R L
- Arms at side R L
- Bolster/Roll/Wedge R L
- Sandbag/Beanbag
- Axillary roll

Comments: _____

HAIR CLIPPED: Yes No N/A

PREP: Yes No

Prep team In OR By: _____

Aseptic clipped 1. _____ 2. _____ 3. _____

Condition of skin Intact Other _____

URINARY CATHETER Yes No Urine Output _____

Indwelling Straight

Inserted by: _____ Type/Size: _____ Removed by: _____

BIPOLAR Yes No **CAUTERY** Yes No

1. Type _____ Number _____

2. Type _____ Number _____

Coag from _____ to _____

Ground location _____

2. Type _____ Number _____

Coag from _____ to _____

Ground location _____

Coag from _____ to _____

cutting from _____ to _____

grounding pad Lot #: _____ exp: _____

TOURNIQUET Yes No

1. Number _____ Pressure _____

2. Number _____ Pressure _____

Location _____ Location _____

Applied by _____ Applied by _____

Duration _____ Duration _____

SPECIAL EQUIPMENT N/A

- Radiolines Stimulus Generator-Type 43A # _____
- Ultrasound # _____
- Defibrillator # _____
- Cryotherapy # _____
- Caviron Ultrasonic Aspirator-Type # _____
- Mira # _____
- Bard Argon Beam Coagulator # _____
- Olympus Continuous Flow Pump # _____
- Sequential Compression Device # _____
- Surgical Stimulizer: PSI _____
- IM Pump # _____
- Nerve Stimulator # _____
- Scope cart # _____
- Doppler # _____
- Electromechanical lithotripter # _____
- Other # _____

I. & D. <input type="checkbox"/> N/A	IV Fluids #1 #2 _____	Site #1 #2 _____	Catheter #1 #2 _____	Amount in #1 #2 _____	
				ml	%
Ophthalmology:	Silicone oil used <input type="checkbox"/> Yes <input type="checkbox"/> No				
	Intraocular gas <input type="checkbox"/> Yes <input type="checkbox"/> No				
	<input type="checkbox"/> N/A				

COUNTS

1st procedure	1st			2nd			3rd		
	Initial	1st	2nd	Initial	1st	2nd	Initial	1st	2nd
Sponges									
Sharps									
Instruments									
2nd procedure	Initial	1st	2nd	3rd					
Sponges									
Sharps									
Instruments									

If count incorrect, action taken: _____

PATHOLOGY

Frozen Yes No # _____ Lab _____

Routine Yes No # _____ Lab _____

Cytology Yes No # _____ Lab _____

Other Yes No # _____ Lab _____

Micro Yes No # _____ Lab _____

Other Yes No # _____ Lab _____

CULTURES

Prostheses/Implant/Graft (type/model/# / serial # / lot # / site / labels) _____

Attest Negative Positive N/A

M30F15
Rev. 9/11



Duke University Hospital

DUKE UNIVERSITY HEALTH SYSTEM

DOCTOR'S ORDERS POST ANESTHESIA CARE UNIT (PACU) ORDERS EYE CENTER

Sub-specialty:

Room:
Library number (if applicable)
Substate (clinic and POC)

DATE	TIME	DOCTOR'S ORDERS																
		<p>DISPOSITION</p> <p><input type="checkbox"/> Admit to PACU</p> <ul style="list-style-type: none"> Initiate PACU Admission and Care Routine Call MD for discharge assessment when criteria met; transfer/discharge pt. when criteria met (after MD assessment) <p>OXYGEN</p> <p>Oxygen to maintain SpO₂ ≥ 94% (or pre-op baseline) by:</p> <p><input type="checkbox"/> nasal cannula <input type="checkbox"/> face mask <input type="checkbox"/> face tent/mist <input type="checkbox"/> tracheal collar</p> <p>Notify anesthesiologists if SpO₂ is < 94% and/or not improving with supplemental oxygen.</p> <p>REGIONAL / NEURAXIAL NARCOTIC ANALGESIA:</p> <p><input type="checkbox"/> EPIDURAL ⇒ SEE EPIDURAL ANALGESIA (M05JP) orders</p> <p><input type="checkbox"/> REGIONAL ⇒ SEE REGIONAL ANALGESIA (M05JQ) orders</p> <p><input type="checkbox"/> NEURAXIAL NARCOTIC ⇒ SEE NEURAXIAL NARCOTIC ANALGESIA (M05HI) orders</p> <p><input type="checkbox"/> Transition to IVPCA for Post Op pain management when patient oriented times 3 ⇒ SEE IVPCA (M05DM) orders</p> <p>OPIOID IV PRN</p> <p>FOR PAIN SCORE 3-6/10: (choose one agent) Discontinue when IVPCA started.</p> <p><input type="checkbox"/> Morphine Sulfate ____ mg IV every ____ minutes PRN. Maximum dose ____ mg until discharge from anesthesia care.</p> <p><input type="checkbox"/> Fentanyl ____ mcg IV every ____ minutes PRN. Maximum dose ____ mcg until discharge from anesthesia care.</p> <p><input type="checkbox"/> Hydromorphone [Dilaudid] ____ mg IV every ____ minutes PRN. Maximum dose ____ mg until discharge from anesthesia care.</p> <p><input type="checkbox"/> _____ mg/mcg IV every ____ minutes PRN. Maximum dose ____ mg/mcg until discharge from anesthesia care.</p> <p>FOR PAIN SCORE 7-10/10: (choose one agent) Discontinue when IVPCA started.</p> <p><input type="checkbox"/> Morphine Sulfate ____ mg IV every ____ minutes PRN. Maximum dose ____ mg until discharge from anesthesia care.</p> <p><input type="checkbox"/> Fentanyl ____ mcg IV every ____ minutes PRN. Maximum dose ____ mcg until discharge from anesthesia care.</p> <p><input type="checkbox"/> Hydromorphone [Dilaudid] ____ mg IV every ____ minutes PRN. Maximum dose ____ mg until discharge from anesthesia care.</p> <p><input type="checkbox"/> _____ mg/mcg IV every ____ minutes PRN. Maximum dose ____ mg/mcg until discharge from anesthesia care.</p> <p>NAUSEA AND VOMITING:</p> <p>For active vomiting, retching or nausea score >3/10, treat with 1st antiemetic and reassess in 15 minutes. If active vomiting, retching or nausea score >3/10 persists or recurs, treat with 2nd antiemetic and reassess in 15 minutes. 2nd antiemetic should be a different agent than the first agent used. If symptoms persist after second antiemetic, call the anesthesiologist.</p> <table border="1" style="width: 100%;"> <thead> <tr> <th>1st antiemetic (select one agent)</th> <th>2nd antiemetic (select one agent)</th> </tr> </thead> <tbody> <tr> <td><input type="checkbox"/> Ondansetron [Zofran] 4 mg IV</td> <td><input type="checkbox"/> Ondansetron [Zofran] 4 mg IV</td> </tr> <tr> <td><input type="checkbox"/> Promethazine [Phenergan] 6.25 mg IV</td> <td><input type="checkbox"/> Promethazine [Phenergan] 6.25 mg IV</td> </tr> <tr> <td><input type="checkbox"/> Dexamethasone [Decadron] 4 mg IV</td> <td><input type="checkbox"/> Dexamethasone [Decadron] 4 mg IV</td> </tr> <tr> <td><input type="checkbox"/> Diphenhydramine [Benadryl] 6.25 mg IV</td> <td><input type="checkbox"/> Diphenhydramine [Benadryl] 6.25 mg IV</td> </tr> <tr> <td><input type="checkbox"/> Droperidol [Inapsine] 0.625 mg IV</td> <td><input type="checkbox"/> Droperidol [Inapsine] 0.625 mg IV</td> </tr> <tr> <td><input type="checkbox"/> Metoclopramide [Reglan] 10 mg IV</td> <td><input type="checkbox"/> Metoclopramide [Reglan] 10 mg IV</td> </tr> <tr> <td><input type="checkbox"/> _____ mg IV</td> <td><input type="checkbox"/> _____ mg IV</td> </tr> </tbody> </table>	1st antiemetic (select one agent)	2nd antiemetic (select one agent)	<input type="checkbox"/> Ondansetron [Zofran] 4 mg IV	<input type="checkbox"/> Ondansetron [Zofran] 4 mg IV	<input type="checkbox"/> Promethazine [Phenergan] 6.25 mg IV	<input type="checkbox"/> Promethazine [Phenergan] 6.25 mg IV	<input type="checkbox"/> Dexamethasone [Decadron] 4 mg IV	<input type="checkbox"/> Dexamethasone [Decadron] 4 mg IV	<input type="checkbox"/> Diphenhydramine [Benadryl] 6.25 mg IV	<input type="checkbox"/> Diphenhydramine [Benadryl] 6.25 mg IV	<input type="checkbox"/> Droperidol [Inapsine] 0.625 mg IV	<input type="checkbox"/> Droperidol [Inapsine] 0.625 mg IV	<input type="checkbox"/> Metoclopramide [Reglan] 10 mg IV	<input type="checkbox"/> Metoclopramide [Reglan] 10 mg IV	<input type="checkbox"/> _____ mg IV	<input type="checkbox"/> _____ mg IV
1st antiemetic (select one agent)	2nd antiemetic (select one agent)																	
<input type="checkbox"/> Ondansetron [Zofran] 4 mg IV	<input type="checkbox"/> Ondansetron [Zofran] 4 mg IV																	
<input type="checkbox"/> Promethazine [Phenergan] 6.25 mg IV	<input type="checkbox"/> Promethazine [Phenergan] 6.25 mg IV																	
<input type="checkbox"/> Dexamethasone [Decadron] 4 mg IV	<input type="checkbox"/> Dexamethasone [Decadron] 4 mg IV																	
<input type="checkbox"/> Diphenhydramine [Benadryl] 6.25 mg IV	<input type="checkbox"/> Diphenhydramine [Benadryl] 6.25 mg IV																	
<input type="checkbox"/> Droperidol [Inapsine] 0.625 mg IV	<input type="checkbox"/> Droperidol [Inapsine] 0.625 mg IV																	
<input type="checkbox"/> Metoclopramide [Reglan] 10 mg IV	<input type="checkbox"/> Metoclopramide [Reglan] 10 mg IV																	
<input type="checkbox"/> _____ mg IV	<input type="checkbox"/> _____ mg IV																	



M30F15



DUKE UNIVERSITY HEALTH SYSTEM

**DOCTOR'S ORDERS
POST ANESTHESIA CARE UNIT
(PACU) ORDERS EYE CENTER**

Addressograph

Name _____
Library number (if called) _____
Birthdate (clinic and PDC) _____

DATE	TIME	DOCTOR'S ORDERS																																																																			
		<p>ORAL ANALGESIA (Preferred route if pt. tolerating oral fluids) (Select only one preparation containing acetaminophen)</p> <p><input type="checkbox"/> Acetaminophen [Tylenol] _____ mg po/PR every _____ hours PRN Pain Score _____ (Do not exceed 4 grams/24 hours)</p> <p><input type="checkbox"/> Oxycodone [Roxicodone] _____ mg po every _____ hours PRN Pain Score _____ Maximum dose _____ mg until discharge from anesthesia care.</p> <p><input type="checkbox"/> Oxycodone-acetaminophen (Percocet) (5/325mg) _____ tablets po every _____ hours PRN Pain Score _____ Maximum dose _____ tablets until discharge from anesthesia care.</p> <p><input type="checkbox"/> _____ mg po/PR every _____ hours PRN Pain Score _____ Maximum dose _____ mg until discharge from anesthesia care.</p> <p>NON-OPIOID IV ANALGESIA (If ordered, give non-opioid analgesic before or with Primary opioid analgesia)</p> <p><input type="checkbox"/> Ketorolac [Toradol] _____ mg IV every _____ hours PRN Pain Score _____ Maximum dose _____ mg until discharge from anesthesia care.</p> <p><input type="checkbox"/> _____ mg IV every _____ PRN Pain Score _____ Maximum dose _____ mg until discharge from anesthesia care.</p> <p>DIAGNOSTICS:</p> <table style="width:100%;"> <tr> <td><input type="checkbox"/> Glucose, point of care -STAT</td> <td><input type="checkbox"/> ABG (arterial blood gas) -STAT</td> </tr> <tr> <td><input type="checkbox"/> ABG (automated blood count) -STAT</td> <td><input type="checkbox"/> Chem CS (Na, K, Cl, CO₂, Crea, BUN Glue) -STAT</td> </tr> <tr> <td><input type="checkbox"/> Type and Screen -STAT</td> <td><input type="checkbox"/> Rule-out myocardial infarction:</td> </tr> <tr> <td><input type="checkbox"/> Electrocardiogram -STAT</td> <td> • CK-MB STAT</td> </tr> <tr> <td> Reason _____</td> <td> • Troponin STAT</td> </tr> <tr> <td><input type="checkbox"/> CXR portable -STAT</td> <td> • EKG -STAT for chest pain</td> </tr> <tr> <td> Reason _____</td> <td></td> </tr> </table> <p>DISCHARGE CRITERIA: (Notify the Anesthesiologist when discharge criteria is met.)</p> <table style="width:100%;"> <tr> <td>• RASS < /=-2</td> <td>• Protective reflexes present</td> </tr> <tr> <td>• Hemodynamically stable</td> <td>• Absence of bladder distention</td> </tr> <tr> <td>(Vital signs +/-20% of patient baseline)</td> <td>• Tubes, catheters, drains patent</td> </tr> <tr> <td>• Absence of active vomiting</td> <td>• Oral temperature ≥ 36° C</td> </tr> <tr> <td>• Skin warm and dry</td> <td>• Dressing dry or marked if drainage present</td> </tr> <tr> <td>• Pain score 5/10 scale or at pre operative baseline</td> <td></td> </tr> </table> <div style="border: 1px solid black; padding: 5px; margin-top: 10px;"> <p style="text-align:center;">Richmond Agitation Sedation Scale (RASS)</p> <table style="width:100%; border-collapse: collapse;"> <thead> <tr> <th>Score</th> <th>Term</th> <th>Description</th> <th></th> </tr> </thead> <tbody> <tr> <td>+4</td> <td>Combative</td> <td>Overtly combative, violent, immediate danger to staff</td> <td></td> </tr> <tr> <td>+3</td> <td>Very agitated</td> <td>Pulls or removes tube(s) or catheter(s); aggressive</td> <td></td> </tr> <tr> <td>+2</td> <td>Agitated</td> <td>Frequent non-purposful movement, fights ventilator</td> <td></td> </tr> <tr> <td>+1</td> <td>Restless</td> <td>Anxious but movements not aggressive vigorous</td> <td></td> </tr> <tr> <td>0</td> <td>Alert and calm</td> <td></td> <td></td> </tr> <tr> <td>-1</td> <td>Drowsy</td> <td>Not fully alert, but has sustained awakening (eye-opening/eye contact) to voice (>10 seconds)</td> <td rowspan="3" style="font-size: 2em; vertical-align: middle;">}</td> </tr> <tr> <td>-2</td> <td>Light sedation</td> <td>Briefly awakens with eye contact to voice (<10 seconds)</td> </tr> <tr> <td>-3</td> <td>Moderate sedation</td> <td>Movement or eye opening to voice (but no eye contact)</td> </tr> <tr> <td>-4</td> <td>Deep sedation</td> <td>No response to voice, but movement or eye opening to physical stimulation</td> <td rowspan="2" style="font-size: 2em; vertical-align: middle;">}</td> </tr> <tr> <td>-5</td> <td>Unarousable</td> <td>No response to voice or physical stimulation</td> </tr> </tbody> </table> </div>	<input type="checkbox"/> Glucose, point of care -STAT	<input type="checkbox"/> ABG (arterial blood gas) -STAT	<input type="checkbox"/> ABG (automated blood count) -STAT	<input type="checkbox"/> Chem CS (Na, K, Cl, CO ₂ , Crea, BUN Glue) -STAT	<input type="checkbox"/> Type and Screen -STAT	<input type="checkbox"/> Rule-out myocardial infarction:	<input type="checkbox"/> Electrocardiogram -STAT	• CK-MB STAT	Reason _____	• Troponin STAT	<input type="checkbox"/> CXR portable -STAT	• EKG -STAT for chest pain	Reason _____		• RASS < /=-2	• Protective reflexes present	• Hemodynamically stable	• Absence of bladder distention	(Vital signs +/-20% of patient baseline)	• Tubes, catheters, drains patent	• Absence of active vomiting	• Oral temperature ≥ 36° C	• Skin warm and dry	• Dressing dry or marked if drainage present	• Pain score 5/10 scale or at pre operative baseline		Score	Term	Description		+4	Combative	Overtly combative, violent, immediate danger to staff		+3	Very agitated	Pulls or removes tube(s) or catheter(s); aggressive		+2	Agitated	Frequent non-purposful movement, fights ventilator		+1	Restless	Anxious but movements not aggressive vigorous		0	Alert and calm			-1	Drowsy	Not fully alert, but has sustained awakening (eye-opening/eye contact) to voice (>10 seconds)	}	-2	Light sedation	Briefly awakens with eye contact to voice (<10 seconds)	-3	Moderate sedation	Movement or eye opening to voice (but no eye contact)	-4	Deep sedation	No response to voice, but movement or eye opening to physical stimulation	}	-5	Unarousable	No response to voice or physical stimulation
<input type="checkbox"/> Glucose, point of care -STAT	<input type="checkbox"/> ABG (arterial blood gas) -STAT																																																																				
<input type="checkbox"/> ABG (automated blood count) -STAT	<input type="checkbox"/> Chem CS (Na, K, Cl, CO ₂ , Crea, BUN Glue) -STAT																																																																				
<input type="checkbox"/> Type and Screen -STAT	<input type="checkbox"/> Rule-out myocardial infarction:																																																																				
<input type="checkbox"/> Electrocardiogram -STAT	• CK-MB STAT																																																																				
Reason _____	• Troponin STAT																																																																				
<input type="checkbox"/> CXR portable -STAT	• EKG -STAT for chest pain																																																																				
Reason _____																																																																					
• RASS < /=-2	• Protective reflexes present																																																																				
• Hemodynamically stable	• Absence of bladder distention																																																																				
(Vital signs +/-20% of patient baseline)	• Tubes, catheters, drains patent																																																																				
• Absence of active vomiting	• Oral temperature ≥ 36° C																																																																				
• Skin warm and dry	• Dressing dry or marked if drainage present																																																																				
• Pain score 5/10 scale or at pre operative baseline																																																																					
Score	Term	Description																																																																			
+4	Combative	Overtly combative, violent, immediate danger to staff																																																																			
+3	Very agitated	Pulls or removes tube(s) or catheter(s); aggressive																																																																			
+2	Agitated	Frequent non-purposful movement, fights ventilator																																																																			
+1	Restless	Anxious but movements not aggressive vigorous																																																																			
0	Alert and calm																																																																				
-1	Drowsy	Not fully alert, but has sustained awakening (eye-opening/eye contact) to voice (>10 seconds)	}																																																																		
-2	Light sedation	Briefly awakens with eye contact to voice (<10 seconds)																																																																			
-3	Moderate sedation	Movement or eye opening to voice (but no eye contact)																																																																			
-4	Deep sedation	No response to voice, but movement or eye opening to physical stimulation	}																																																																		
-5	Unarousable	No response to voice or physical stimulation																																																																			
Signature: _____		Title: _____ Pager #: _____ Date: _____ Time: _____																																																																			

Appendix C

Peer and Professional Associations Listing.



Nursing

1. American Society of Ophthalmic Registered Nurses www.asorn.org
2. Australian Ophthalmic Nurses Association(s) – State based:
 - New South Wales www.aonansw.org.au
 - Queensland www.aona.org.au
 - Victoria (including South Australia and Tasmania) www.aonavic.org.au
 - Western Australia www.aonawa.org.au
3. Canadian Ophthalmic Nurses Association www.csorn.org.ca
4. European Society of Ophthalmic Nurses and Technicians www.esocrs.org/esont
5. International Council of Nurses www.icn.ch
6. International Ophthalmic Nurses Association (UK) www.iona-online.org
7. Nigerian Ophthalmic Nurses Association – find them on facebook via: Nigerian Ophthalmic Nurses Association
8. Peruvian Ophthalmic Nurses Association – find them on facebook via: ASOCIACIÓN PERUANA DE ENFERMEROS EN OFTALMOLOGÍA (APEO)
9. World Health Organization – Health Workforce Nursing and Midwifery www.who.int/hrh/nursing_midwifery/en

Other

1. American Society of Ocularists www.ocularist.org
2. Community Eye Health Journal www.cehjournal.org
3. Global Alliance of Eye Bank Associations www.gaeba.org
4. International Association for Public Health Logisticians <http://iaphl.org> (a Supply Chain Management group)
5. International Agency for the Prevention of Blindness www.iapb.org
6. International Council of Ophthalmology www.icoph.org
7. International Orthoptics Association www.internationalortho.org
8. Joint Commission on Allied Health Personnel in Ophthalmology www.jcahpo.org
9. London School of Hygiene and Tropical Medicine www.lshtm.ac.uk
10. World Council of Optometry www.worldoptometry.org
11. World Federation of Societies of Anaesthesiologists www.wfsahq.org
12. World Health Organization – Blindness www.who.int/topics/blindness/en

Combined Professional Regional Associations

Oceania

Pacific Eye Care Society (PacEYES) – Pacific Islands
www.paceyes.org

South America

Pan-American Association of Ophthalmology
www.paaao.org

West Indies

Ophthalmological Society of the West Indies
www.oswinet.org

www.cehjournal.org

